



# Instruction Manual

Free Float Steam Trap

**QuickTrap**®  
**FS3 / FS5 / FS5H**

**Trap Unit**  
**S3 / S5 / S5H**

(For Connector Body F46)

## Contents

Introduction .....	1
Safety Considerations .....	2
Checking the Piping .....	4
Specifications .....	5
Compatibility .....	5
Configuration .....	6
Installation .....	7
Maintenance .....	9
Disassembly/Reassembly .....	10
Instructions for Plug/Holder Disassembly and Reassembly .....	12
Troubleshooting .....	13
Product Warranty .....	14
Options .....	15

## Introduction

Thank you for purchasing the **TLV** free float steam trap.

This product has been thoroughly inspected before being shipped from the factory. When the product is delivered, before doing anything else, check the specifications and external appearance to make sure nothing is out of the ordinary. Also be sure to read this manual carefully before use and follow the instructions to be sure of using the product properly.

This free float steam trap uses a universal flange, a precision-polished float and three-point support for the valve body. With no hinges or levers, the trap automatically continuously discharges condensate, preventing it from collecting. The three-point seating for the valve body supports the precision-polished float securely at three points and ensures a high degree of sealing for even minute quantities of condensate. The universal flange allows the trap to be installed in either horizontal or vertical piping. This flexibility greatly reduces the time required for installation and removal, as compared to conventional steam traps, and also facilitates repair and maintenance operations.





If detailed instructions for special order specifications or options not contained in this manual are required, please contact **TLV** for full details.

This instruction manual is intended for use with the model(s) listed on the front cover. It is necessary not only for installation, but for subsequent maintenance, disassembly/reassembly and troubleshooting. Please keep it in a safe place for future reference.

## Safety Considerations

- Read this section carefully before use and be sure to follow the instructions.
- Installation, inspection, maintenance, repairs, disassembly, adjustment and valve opening/closing should be carried out only by trained maintenance personnel.
- The precautions listed in this manual are designed to ensure safety and prevent equipment damage and personal injury. For situations that may occur as a result of erroneous handling, three different types of cautionary items are used to indicate the degree of urgency and the scale of potential damage and danger: DANGER, WARNING and CAUTION.
- The three types of cautionary items above are very important for safety: be sure to observe all of them as they relate to installation, use, maintenance and repair. Furthermore, TLV accepts no responsibility for any accidents or damage occurring as a result of failure to observe these precautions.

### Symbols

	Indicates a <b>DANGER, WARNING or CAUTION</b> item.
	Indicates an urgent situation which poses a threat of death or serious injury
	Indicates that there is a potential threat of death or serious injury
	Indicates that there is a possibility of injury or equipment / product damage

	<b>Install properly and DO NOT use this product outside the recommended operating pressure, temperature and other specification ranges.</b> Improper use may result in such hazards as damage to the product or malfunctions that may lead to serious accidents. Local regulations may restrict the use of this product to below the conditions quoted.
	<b>DO NOT use this product in excess of the maximum operating pressure differential.</b> Such use could make discharge impossible (blocked).
	<b>Take measures to prevent people from coming into direct contact with product outlets.</b> Failure to do so may result in burns or other injury from the discharge of fluids.
	<b>When disassembling or removing the product, wait until the internal pressure equals atmospheric pressure and the surface of the product has cooled to room temperature.</b> Disassembling or removing the product when it is hot or under pressure may lead to discharge of fluids, causing burns, other injuries or damage.

Safety considerations continued on next page.

 <b>CAUTION</b>	<p><b>Be sure to use only the recommended components when repairing the product, and NEVER attempt to modify the product in any way.</b></p> <p>Failure to observe these precautions may result in damage to the product and burns or other injury due to malfunction or the discharge of fluids.</p>
	<p><b>Use only under conditions in which no freeze-up will occur.</b></p> <p>Freezing may damage the product, leading to fluid discharge, which may cause burns or other injury.</p>
	<p><b>The pressure and temperature values displayed on the nameplate of the connector body are the values for the connector body itself and not for the entire trap.</b></p> <p>Improper use may result in such hazards as damage to the product or malfunctions that may lead to serious accidents.</p>
	<p><b>Use only under conditions in which no water hammer will occur.</b></p> <p>The impact of water hammer may damage the product, leading to fluid discharge, which may cause burns or other injury.</p>

## Checking the Piping



Use only under conditions in which no water hammer will occur. The impact of water hammer may damage the product, leading to fluid discharge, which may cause burns or other injury.

Check to make sure that the pipes to be connected to the trap have been installed properly.

1. Is the pipe diameter suitable?
2. Has sufficient space been secured for maintenance?
3. Have isolation valves been installed at the inlet and outlet? If the outlet is subject to back pressure, has a check valve (TLV-CK) been installed?
4. Is the inlet pipe as short as possible, with as few bends as possible, and installed so the liquid will flow naturally down into the trap?
5. Has the piping work been done correctly, as shown in the figures below?

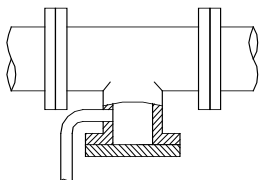
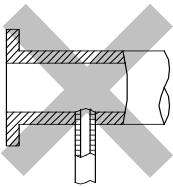
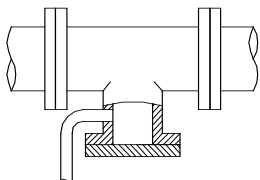
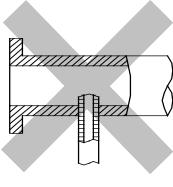
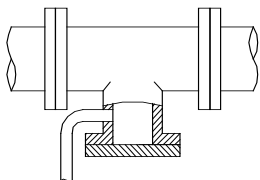
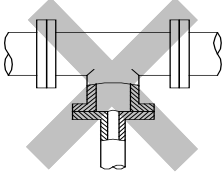
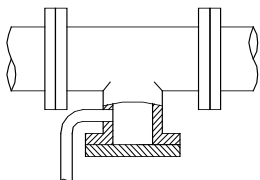
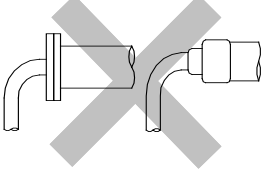
Requirement	Correct	Incorrect
Install catchpot with the proper diameter.		 Diameter is too small.
Make sure the flow of condensate is not obstructed.		 Diameter is too small and inlet protrudes into pipe interior.
To prevent rust and scale from flowing into the trap, the inlet pipe should be connected 25 – 50 mm (1 – 2 in) above the base of the T-pipe.		 Rust and scale flow into the trap with the condensate.
When installing on the blind end, make sure the flow of condensate is not obstructed.		 Condensate collects in the pipe.

## Specifications



Install properly and **DO NOT** use this product outside the recommended operating pressure, temperature and other specification ranges. Improper use may result in such hazards as damage to the product or malfunctions which may lead to serious accidents. Local regulations may restrict the use of this product to below the conditions quoted.



**DO NOT** use this product in excess of the maximum operating pressure differential; such use could make discharge impossible (blocked).



Use only under conditions in which no freeze-up will occur. Freezing may damage the product, leading to fluid discharge, which may cause burns or other injury.



The pressure and temperature values displayed on the nameplate of the connector body are the values for the connector body itself and not for the entire trap. Improper use may result in such hazards as damage to the product or malfunctions that may lead to serious accidents.

Refer to the product nameplates on the trap unit **AND** on the connector body for detailed specifications.

The specifications displayed on each nameplate apply only to the unit on which it is mounted. When a trap unit is installed on a connector unit and the PMA/TMA and/or PMO/TMO values displayed on the two nameplates differ, the specifications for the assembled product are restricted to the lower values.

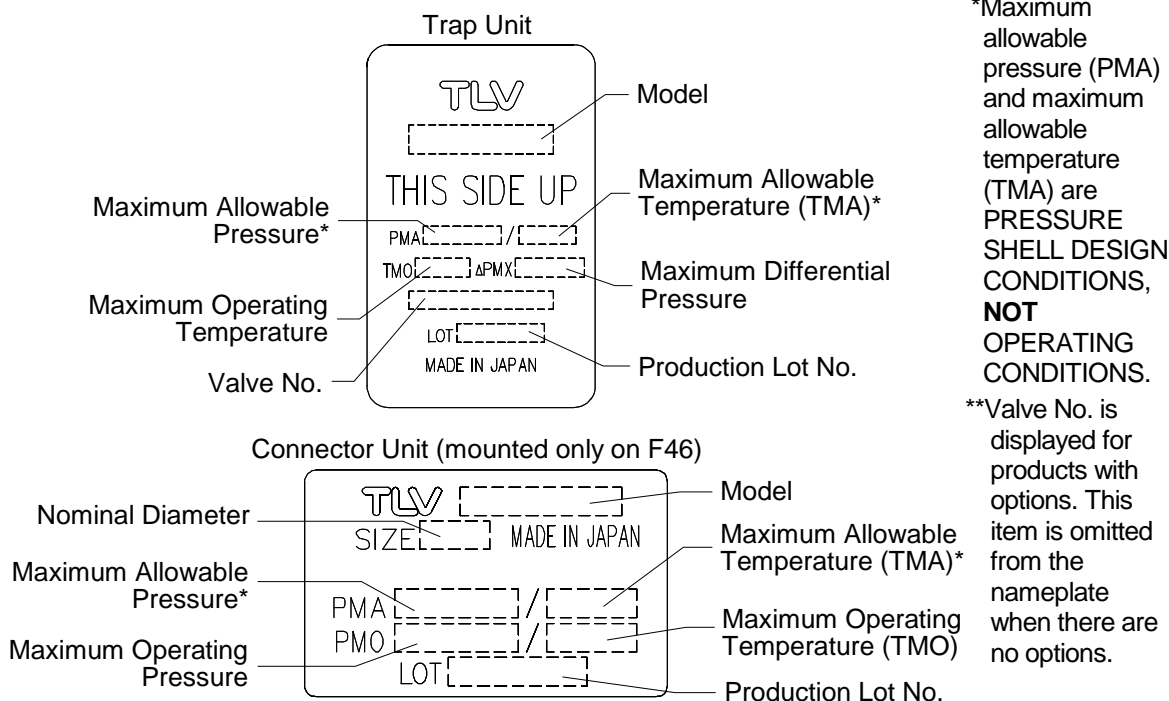

## Compatibility

- The FS3/FS5/FS5H QuickTrap series employs a **TLV** connector unit (F46) and is not compatible with QuickTrap models using connector unit F46J.
- Trap unit (S3/S5/S5H) is compatible with **TLV** Trap Stations (V1/V2/V1P/V2P Series) and can be installed on those trap stations or connector unit (F32).

The connector unit name is embossed on the connector body.

## Configuration

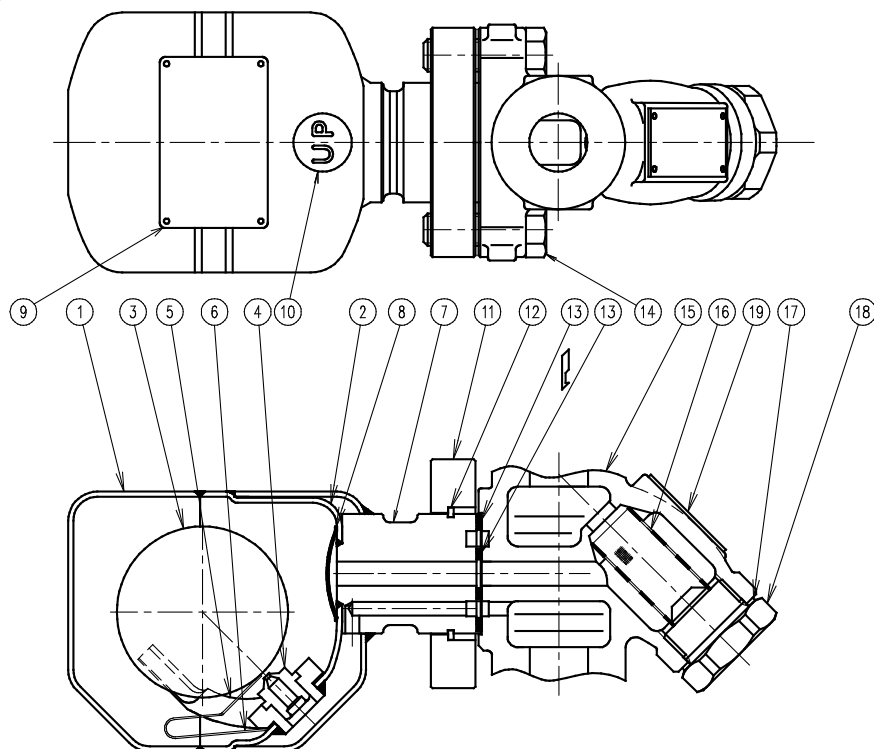

No.	Name	M	T	C
1	Trap Body		✓	
2	Inner Cover		✓	
3	Float		✓	
4	Orifice		✓	
5	Float Guide		✓	
6	Air Vent Strip		✓	
7	Connector Joint		✓	
8	Trap Screen		✓	
9	Nameplate		✓	
10	UP Seal*		✓	
11	Connector Flange		✓	
12	Snap Ring		✓	
13	Inner/Outer Connector Gaskets	✓	✓	
14	Connector Bolt		✓	
15	Connector Body			✓
16	Screen			✓
17	Screen Holder Gasket	✓		✓
18	Screen Holder			✓
19	Connector Nameplate			✓

M: Maintenance Kit

T: Trap Unit (S3/S5/S5H)

C: Connector Unit (F46)

\*Not always included

NOTE: Replacement parts for former connector body F32 differ from those for F46. When you order replacement parts, please include the steam trap model name, size, connection type and also the connector unit name.

## Installation



Install properly and **DO NOT** use this product outside the recommended operating pressure, temperature and other specification ranges. Improper use may result in such hazards as damage to the product or malfunctions which may lead to serious accidents. Local regulations may restrict the use of this product to below the conditions quoted.



Take measures to prevent people from coming into direct contact with product outlets. Failure to do so may result in burns or other injury from the discharge of fluids.

Installation, inspection, maintenance, repairs, disassembly, adjustment and valve opening/closing should be carried out only by trained maintenance personnel.

1. Before installation, be sure to remove all protective seals.
2. Before installing the product, blow out the inlet piping to remove any piping scraps, dirt and oil. Close the inlet valve after blowdown.
3. Install the product so the arrow on the body is pointing in the direction of condensate flow.
4. The connector body has no restrictions on installation orientation except for the following conditions: the universal flange face (for connecting to the trap unit) must be in the vertical plane, and the trap unit must be installed with the nameplate facing upwards.
5. The trap unit must be installed with the nameplate facing upward, and should be inclined no more than 5° in any plane. Use the two connector bolts to adjust the angle of the trap unit.
6. Install a condensate outlet valve and outlet piping.
7. Open the inlet and outlet valves and check to make sure that the product functions properly.

If there is a problem, determine the cause using the “Troubleshooting” section in this manual.

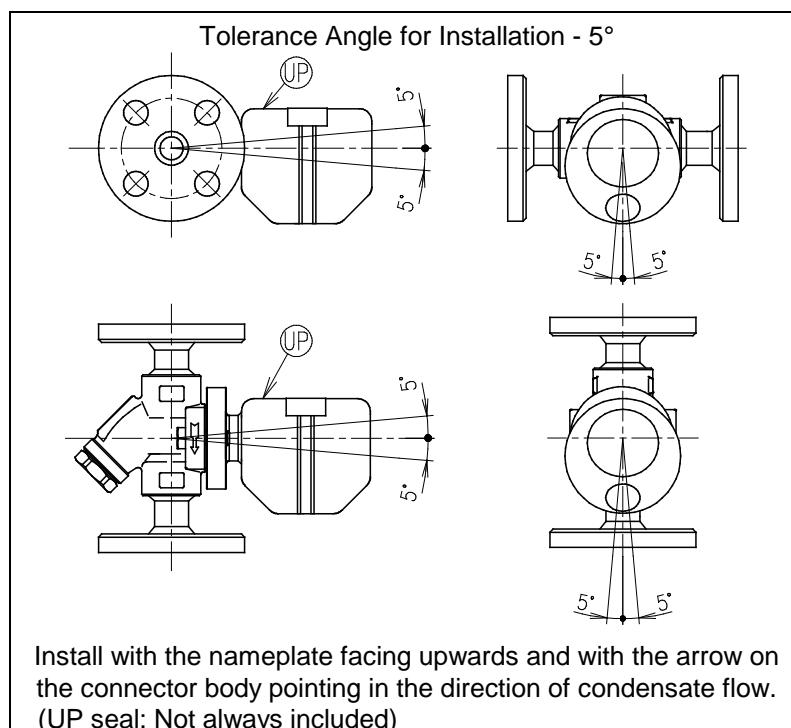

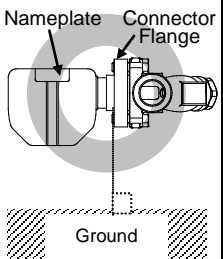
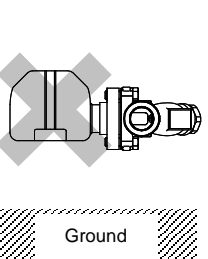
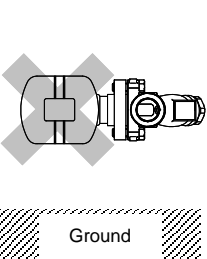
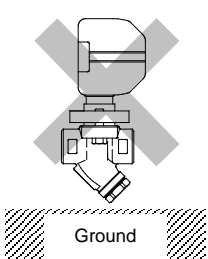
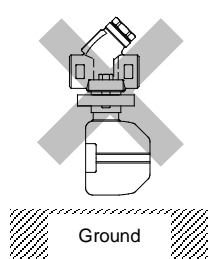

### Installation Examples: Horizontal Piping

Correct	Incorrect			
	Nameplate not facing upwards		Universal Connector Flange not in the vertical plane	
 <p>Nameplate Connector Flange</p> <p>Ground</p>	 <p>Ground</p>	 <p>Ground</p>	 <p>Ground</p>	 <p>Ground</p>

### Installation Examples: Vertical Piping

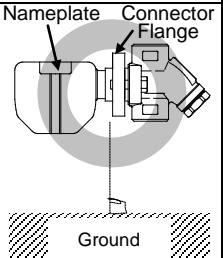
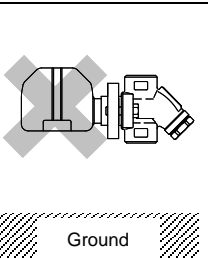
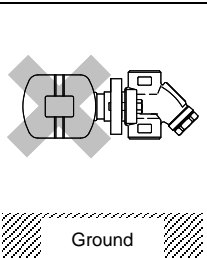
Correct	Incorrect	
	Nameplate not facing upwards	
 <p>Nameplate Connector Flange</p> <p>Ground</p>	 <p>Ground</p>	 <p>Ground</p>

#### Note for FS5/FS5H with Screwed Connection:

When products with screwed connections are installed on horizontal piping, there is a danger that the weight of the trap unit will cause the connector body to rotate on the pipe beyond the allowable angle of inclination preventing proper trap operation. To prevent this, tighten the screws securely. In cases where the product is affected by vibrations or by external contact, it is recommended that the trap unit should be supported to prevent rotation (sample support shown to the right).

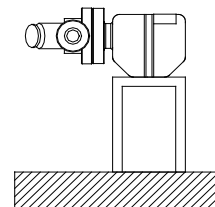

## Maintenance



Take measures to prevent people from coming into direct contact with product outlets. Failure to do so may result in burns or other injury from the discharge of fluids.



Be sure to use only the recommended components when repairing the product, and NEVER attempt to modify the product in any way. Failure to observe these precautions may result in damage to the product or burns or other injury due to malfunction or the discharge of fluids.

## Operational Check

A visual inspection of the following items should be done on a daily basis to determine whether the trap is operating properly or has failed. Periodically (at least biannually) the operation should also be checked by using diagnostic equipment such as a stethoscope, thermometer, TLV Pocket TrapMan or TLV TrapMan.

If the trap should fail, it may cause damage to piping and equipment, resulting in faulty or low quality products or losses due to steam leakage.

- |                                   |   |
|-----------------------------------|---|
| Normal                            | : Condensate is discharged continuously, together with flash steam, and the sound of flow can be heard. If there is very little condensate, there is almost no sound of flow. |
| Blocked<br>(Discharge Impossible) | : No condensate is discharged. The trap is quiet and makes no noise, and the surface temperature of the trap is low.  |
| Blowing                           | : Live steam continually flows from the outlet and there is a continuous metallic sound.  |
| Steam Leakage                     | : Live steam is discharged through the trap outlet together with condensate, accompanied by a high-pitched sound.   |

(When conducting a visual inspection, flash steam is sometimes mistaken for steam leakage. For this reason, the use of a steam trap diagnostic instrument [such as TLV TrapMan if appropriate] in conjunction with the visual inspection is highly recommended.)

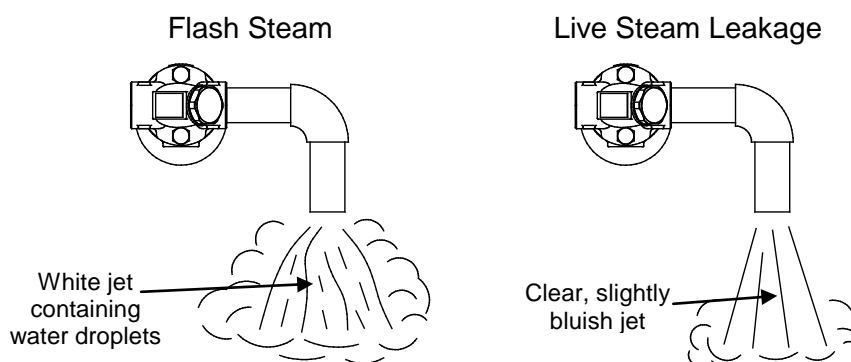

## Parts Inspection

When parts have been removed, or during periodic inspections, use the following table to inspect the parts and replace any that are found to be defective.

Procedure
Gaskets: Check for warping or scratches
Screens: Check for clogging or corrosion
Trap Unit, Connector Body: check inside bodies for rust and scale

## Disassembly/Reassembly



When disassembling or removing the product, wait until the internal pressure equals atmospheric pressure and the surface of the product has cooled to room temperature. Disassembling or removing the product when it is hot or under pressure may lead to discharge of fluids, causing burns, other injuries or damage.

Use the following procedures to remove components. Use the same procedures in reverse to reassemble. (Installation, inspection, maintenance, repairs, disassembly, adjustment and valve opening/closing should be carried out only by trained maintenance personnel.)

### Detaching/Reattaching the Trap Unit

Part	During Disassembly	During Reassembly
Connector Bolts	Remove with a socket wrench	Consult the table of tightening torques and tighten to the proper torque
Trap Unit	Remove the trap unit	Follow the special instructions below (See Fig. A)
Connector Gaskets	Remove with a scraper and clean the connector flange with a soft tool.	Replace with new gaskets; to facilitate assembly and prevent loosening of the gaskets, apply a small amount of adhesive at 120° intervals around the outer edge of the gaskets

#### Attaching the Trap Unit to the Connector Body

1. If attaching a new trap unit, be sure to remove the protective cap from the connector flange. Be careful not to drop the gaskets when removing the cap.
2. Grasp the end of the trap unit and align its gasket housing with the indentation on the connector body. Be sure to have the nameplate facing upwards.
3. Once aligned, insert and finger tighten the connector bolts. Verify that the trap unit is within the allowable inclination.

Figure A

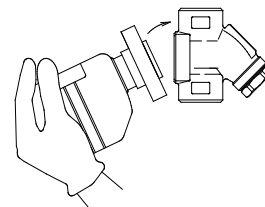

### Disassembly/Reassembly of Components Inside the Connector Body

Part	During Disassembly	During Reassembly
Screen Holder	Remove with a socket wrench	Consult the table of tightening torques and tighten to the proper torque
Screen Holder Gasket	Remove the gasket	Replace with a new gasket only if warped or damaged
Screen	Remove with needle-nose pliers	Insert securely into the connector body

## Table of Tightening Torques

Part Name			Torque		Distance Across Flats		
			N·m	(lbf·ft)	mm	(in)	
Connector Bolt			39	(28)	14	( <sup>9</sup> / <sub>16</sub> )	
Screen Holder (when F46 is used)			100	(73)	30	(1 <sup>3</sup> / <sub>16</sub> )	
Screen Holder (when F32 is used)	Flanged	15 – 25 mm ( <sup>1</sup> / <sub>2</sub> – 1 in)	60	(44)	22	( <sup>7</sup> / <sub>8</sub> )	
		15 · 20 mm ( <sup>1</sup> / <sub>2</sub> · <sup>3</sup> / <sub>4</sub> in)	60	(44)	22	( <sup>7</sup> / <sub>8</sub> )	
	Screwed	25 mm (1 in)	150	(110)	38	(1 <sup>1</sup> / <sub>2</sub> )	
		Socket Welded	15 · 20 mm ( <sup>1</sup> / <sub>2</sub> · <sup>3</sup> / <sub>4</sub> in)	60	(44)	22	( <sup>7</sup> / <sub>8</sub> )
			25 mm (1 in)	150	(110)	38	(1 <sup>1</sup> / <sub>2</sub> )

NOTE: -Coat all threaded portions with anti-seize. (1 N·m ≈ 10 kg·cm)  
 -If drawings or other special documentation were supplied for the product, any torque given there takes precedence over values shown here.

Screen Holders for Connector Units F32 and F46 can be used only with their respective connector body.

When disassembling and reassembling the components, make sure the correct connector unit (F32 or F46) is used. The type of connector unit can be identified by the name embossed on its body.

## Exploded View

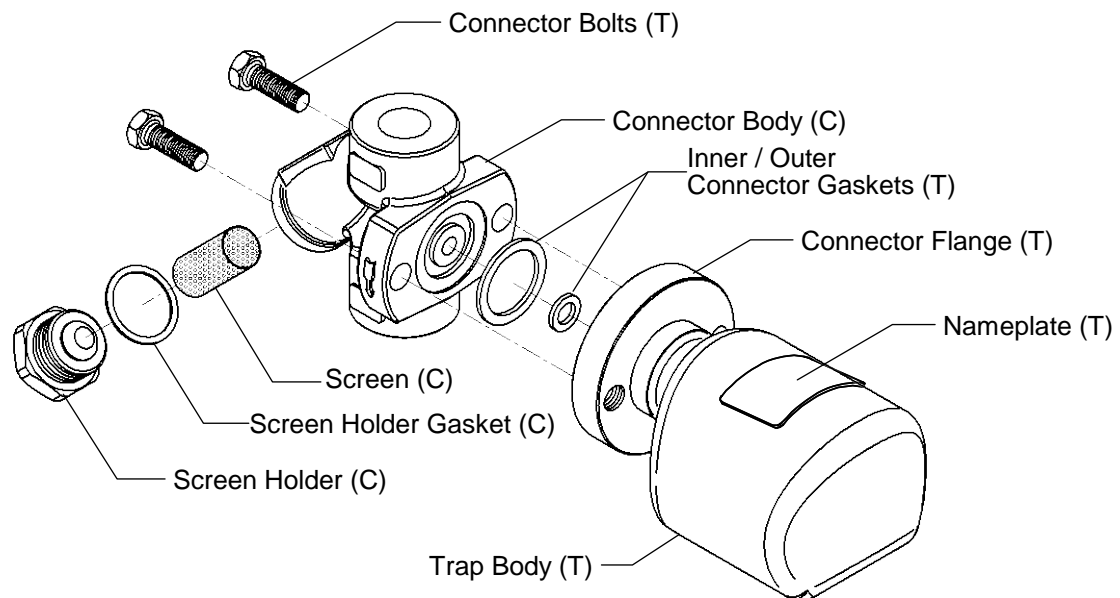

(T) Trap Unit  
(C) Connector Unit

## Instructions for Plug/Holder Disassembly and Reassembly

The seal on the threaded plugs/holders found on TLV products is formed by a flat metal gasket. There are various installation orientations for the gaskets, such as horizontal, diagonal and downward, and the gasket may be pinched in the thread recesses during assembly.

### Instructions for Disassembly and Reassembly

- ① Remove the plug/holder using a tool of the specified size (distance across flats).
- ② The gasket should not be reused. Be sure to replace it with a new gasket.
- ③ Clean the gasket surfaces of the plug/holder and the product body using a rag and/or cleaning agents, then check to make sure the surfaces are not scratched or deformed.
- ④ Coat both the gasket surface of the plug/holder and the threads of the plug/holder with anti-seize, then press the gasket onto the center of the gasket surface of the plug/holder, making sure the anti-seize affixes the gasket tightly to the plug/holder. Check to make sure the gasket is not caught in the recesses of the threads.
- ⑤ Hold the plug/holder upside down to make sure that the anti-seize makes the gasket stick to the plug/holder even when the plug/holder is held upside down.
- ⑥ Screw the plug/holder by hand into the product body while making sure that the gasket remains tightly affixed to the center of the gasket surface of the plug/holder. Make sure the entire gasket is making contact with the gasket surface of the product body. It is important at this point to make sure the gasket is not pinched in the thread recesses of the plug/holder.
- ⑦ Tighten the plug/holder to the proper torque.
- ⑧ Next, begin the supply of steam and check to make sure there is no leakage from the part just tightened. If there is leakage, immediately close the inlet valve and, if there is a bypass valve, take the necessary steps to release any residual pressure. After the surface of the product cools to room temperature, repeat the procedure beginning from step ①.

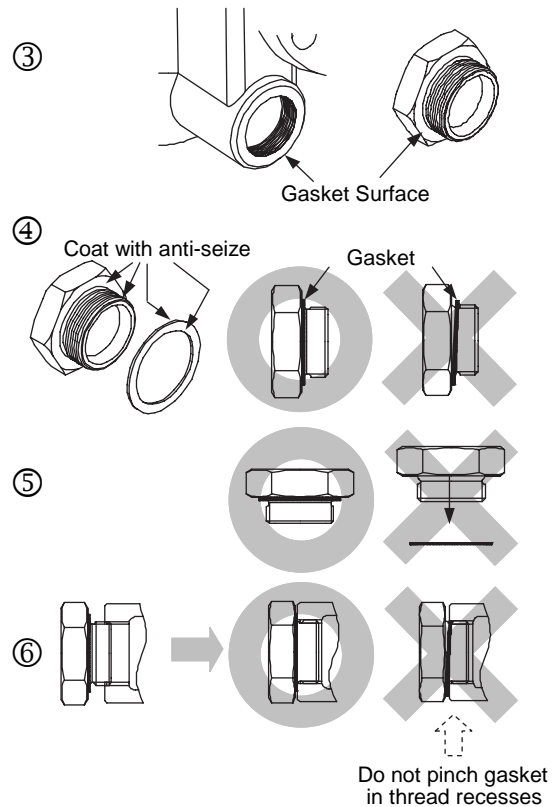

## Troubleshooting



When disassembling or removing the product, wait until the internal pressure equals atmospheric pressure and the surface of the product has cooled to room temperature. Disassembling or removing the product when it is hot or under pressure may lead to discharge of fluids, causing burns, other injuries or damage.

If the product fails to operate properly, use the following table to locate the cause and remedy.

Problem	Cause	Remedy
No condensate is discharged (blocked) or discharge is poor	The screen or inlet/outlet channels on the connector body are clogged with rust and scale	Clean
	The trap operating pressure exceeds the maximum specified pressure, or whether there is insufficient pressure differential between the trap inlet and outlet	Compare specifications and actual operating conditions
	Steam-locking has occurred	Perform a bypass blowdown or close the trap inlet valve and allow the trap to cool
Steam is discharged or leaks from the outlet (blowing) (steam leakage)	Improper installation orientation	Correct the installation
	Excessive trap vibration	Lengthen the inlet piping and fasten it securely
	Water hammer has occurred	Examine for problems that can cause water hammer and correct the piping
Steam is leaking from a place other than the outlet	The gaskets have deterioration or damage	Replace with new gaskets
	Improper tightening torque was used	Tighten to the proper torque

NOTE: S3/S5/S5H steam trap units are of all-welded, single unit construction, so they cannot be repaired. If parts need replacement, refer to the parts list in this manual and select the appropriate kit/unit for replacement parts. Parts are only available as a part of the kits/units shown.

## Product Warranty

1. Warranty Period  
One year following product delivery.
2. Warranty Coverage  
TLV CO., LTD. warrants this product to the original purchaser to be free from defective materials and workmanship. Under this warranty, the product will be repaired or replaced at our option, without charge for parts or labor.
3. This product warranty will not apply to cosmetic defects, nor to any product whose exterior has been damaged or defaced; nor does it apply in the following cases:
  - 1) Malfunctions due to improper installation, use, handling, etc., by other than TLV CO., LTD. authorized service representatives.
  - 2) Malfunctions due to dirt, scale, rust, etc.
  - 3) Malfunctions due to improper disassembly and reassembly, or inadequate inspection and maintenance by other than TLV CO., LTD. authorized service representatives.
  - 4) Malfunctions due to disasters or forces of nature.
  - 5) Accidents or malfunctions due to any other cause beyond the control of TLV CO., LTD.
4. Under no circumstances will TLV CO., LTD. be liable for consequential economic loss damage or consequential damage to property.

\* \* \* \* \*

For Service or Technical Assistance:

Contact your **TLV** representative or your regional **TLV** office.

### Manufacturer

**TLV** CO., LTD.  
881 Nagasuna, Noguchi  
Kakogawa, Hyogo 675-8511 JAPAN  
Tel: 81-(0)79-427-1800

## Options

### With Blowdown Valve (TLV BD2)



Always wear eye protection and heat-resistant gloves when operating the blowdown valve. Failure to do so may result in burns or other injury.



When operating the blowdown valve, stand to the side well clear of the outlet to avoid contact with internal fluids that will be discharged. Operate the valve slowly and surely, taking care to avoid the area from which internal fluids are discharged and any fluids deflected off piping or the ground etc. Failure to do so may result in burns or other injury.



Do not tighten the BD2 valve or the BD2 valve seat in excess of the appropriate tightening torque. Over-tightening may cause breakage to threaded portions, which may cause burns, other injuries or damage.



Do not excessively loosen the BD2 valve when opening the blowdown valve. The valve stopper pin installed to prevent the BD2 valve from being removed may break and internal pressure may result in the BD2 valve being blown off, leading to injuries, damage and fluid discharge, causing burns.

### Configuration

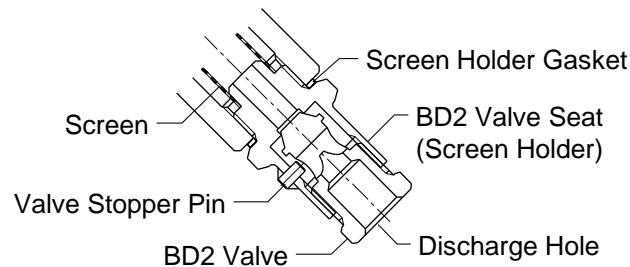

### TLV Blowdown Valve: BD2

The BD2 Blowdown Valve, installed in the screen area of the connector body, uses the trap's internal pressure to blow any condensate, steam, dirt or scale accumulated around the screen area out to atmosphere.



### BD2 Blowdown Valve Operation

1. The BD2 valve is in the closed position when the BD2 is shipped from the factory. Before attempting to operate the BD2, reconfirm that the BD2 valve is still in the closed position. Locate the blow outlet and, during operation, stand to the side and well clear of it, as the jet of condensate or steam could cause burns.
2. Remain in the area the entire time the BD2 valve is in the open position. Before opening the BD2 valve, grip the BD2 valve seat with a wrench and hold firmly in place so that it will not rotate when the BD2 valve is loosened. Grip the BD2 valve with another wrench and slowly loosen. Condensate and steam will discharge from the blow outlet in a jet stream. Be careful not to loosen the BD2 valve so far that it becomes removed from the BD2 valve seat. (If the valve stopper pin becomes damaged, large quantities of steam will be discharged in a jet stream.)
3. Close the BD2 valve until the flow of fluid completely stops. If the flow of fluid does not stop, re-open the BD2 valve (as in step "2") to blow out any scale or dirt that may be caught in the BD2. Re-tighten the BD2 valve until the flow of fluid stops completely.

Tightening Torques and Distance Across Flats						
Part Name			Torque		Distance Across Flats	
			N·m	(lbf·ft)	mm	(in)
BD2 Valve			30	(22)	17	( <sup>21</sup> / <sub>32</sub> )
BD2 Valve Seat (Screen Holder) (when F46 is used)			100	(73)	30	( <sup>3</sup> / <sub>16</sub> )
BD2 Valve Seat (Screen Holder) (when F32 is used)	Flanged	15 – 25 mm ( <sup>1</sup> / <sub>2</sub> – 1 in)	60	(44)	22	( <sup>7</sup> / <sub>8</sub> )
	Screwed	15 · 20 mm ( <sup>1</sup> / <sub>2</sub> , <sup>3</sup> / <sub>4</sub> in)	60	(44)	22	( <sup>7</sup> / <sub>8</sub> )
		25 mm (1 in)	150	(110)	38	( <sup>1</sup> / <sub>2</sub> )
	Socket Welded	15 · 20 mm ( <sup>1</sup> / <sub>2</sub> , <sup>3</sup> / <sub>4</sub> in)	60	(44)	22	( <sup>7</sup> / <sub>8</sub> )
		25 mm (1 in)	150	(110)	38	( <sup>1</sup> / <sub>2</sub> )

NOTE: Avoid the use of excessive tightening torques, as threaded parts may become damaged. (1 N·m ≈ 10 kg·cm)