



Manufacturer

**TLV. CO., LTD.**

Kakogawa, Japan

is approved by LRQA LTD. to ISO 9001/14001



# Instruction Manual

Rapid Initial Air Vent  
**VAS**

Copyright © 2015 by TLV CO., LTD.

All rights reserved

## Contents

Introduction .....	1
Safety Considerations .....	2
Features .....	4
Operation .....	4
Specifications .....	5
Configuration .....	5
Installation .....	6
Maintenance.....	7
Disassembly/Reassembly .....	8
Troubleshooting .....	10
Product Warranty .....	11

## Introduction

Thank you for purchasing the **TLV** Rapid Initial Air Vent.

This product has been thoroughly inspected before being shipped from the factory. When the product is delivered, before doing anything else, check the specifications and external appearance to make sure nothing is out of the ordinary. Also be sure to read this manual carefully before use and follow the instructions to be sure of using the product properly.

This Rapid Initial Air Vent is for use on water-bearing pipes, and should therefore not be used on steam lines.

The Rapid Initial Air Vent operates by rapidly discharging the initial air when supplying water to piping, then closing upon completion of discharge. During operation, once it has closed, the air vent remains closed as long as there is internal pressure. When draining piping, the Rapid Initial Air Vent automatically opens to introduce air and remove water easily.

The Rapid Initial Air Vent 's simple, compact construction, with no hinges or levers and only one moving part, the float, provides trouble-free operation and long service life.







If detailed instructions for special order specifications or options not contained in this manual are required, please contact **TLV** for full details.

This instruction manual is intended for use with the model(s) listed on the front cover. It is necessary not only for installation but for subsequent maintenance, disassembly/reassembly and troubleshooting. Please keep it in a safe place for future reference.

## Safety Considerations

- Read this section carefully before use and be sure to follow the instructions.
- Installation, inspection, maintenance, repairs, disassembly, adjustment and valve opening/closing should be carried out only by trained maintenance personnel.
- The precautions listed in this manual are designed to ensure safety and prevent equipment damage and personal injury. For situations that may occur as a result of erroneous handling, three different types of cautionary items are used to indicate the degree of urgency and the scale of potential damage and danger: DANGER, WARNING and CAUTION.
- The three types of cautionary items above are very important for safety: be sure to observe all of them as they relate to installation, use, maintenance, and repair. Furthermore, TLV accepts no responsibility for any accidents or damage occurring as a result of failure to observe these precautions.

### Symbols

	<b>Indicates a DANGER, WARNING or CAUTION item.</b>
 <b>DANGER</b>	Indicates an urgent situation which poses a threat of death or serious injury
 <b>WARNING</b>	Indicates that there is a potential threat of death or serious injury
 <b>CAUTION</b>	Indicates that there is a possibility of injury or equipment / product damage
 <b>WARNING</b>	<p><b>DO NOT use for toxic, flammable or otherwise hazardous fluids.</b></p> <p>This product is an air vent that discharges air from water piping system. Use only for water and/or air. This product is for intended use only. Improper use may result in such hazards as damage to the product or malfunctions that may lead to serious accidents.</p> <p><b>NEVER apply direct heat to the float.</b></p> <p>The float may explode due to increased internal pressure, causing accidents leading to serious injury or damage to property and equipment.</p>
 <b>CAUTION</b>	<p><b>Install properly and DO NOT use this product outside the recommended operating pressure, temperature and other specification ranges.</b></p> <p>Improper use may result in such hazards as damage to the product or malfunctions that may lead to serious accidents. Local regulations may restrict the use of this product to below the conditions quoted.</p>

Safety considerations continued on next page.

 <b>CAUTION</b>	<p><b>Take measures to prevent people from coming into direct contact with product outlets.</b> Failure to do so may result in burns or other injury from the discharge of fluids.</p>
	<p><b>When disassembling or removing the product, wait until the internal pressure equals atmospheric pressure and the surface of the product has cooled to room temperature.</b> Disassembling or removing the product when it is hot or under pressure may lead to discharge of fluids, causing burns, other injuries or damage.</p>
	<p><b>Be sure to use only the recommended components when repairing the product, and NEVER attempt to modify the product in any way.</b> Failure to observe these precautions may result in damage to the product and burns or other injury due to malfunction or the discharge of fluids.</p>
	<p><b>Do not use excessive force when connecting threaded pipes to the product.</b> Over-tightening may cause breakage leading to fluid discharge, which may cause burns or other injury.</p>
	<p><b>Use only under conditions in which no freeze-up will occur.</b> Freezing may damage the product, leading to fluid discharge, which may cause burns or other injury.</p>
	<p><b>Use only under conditions in which no water hammer will occur.</b> The impact of water hammer may damage the product, leading to fluid discharge, which may cause burns or other injury.</p>

## Features

1. The air vent has no hinges or levers: the only moving part is the precision-ground float, which eliminates concentrated wear and provides long service life.
2. Simple construction with few parts allows for easy maintenance.
3. The air vent is small and light.

## Operation



Take measures to prevent people from coming into direct contact with product outlets. Failure to do so may result in burns or other injury from the discharge of fluids.

1. When water is transported, air inside the piping is forced into the air vent by the pressure of the flow. The float inside the air vent is in the lower position, thus the valve is fully open and allows the air that enters the air vent and fills the area around the float to then be discharged.

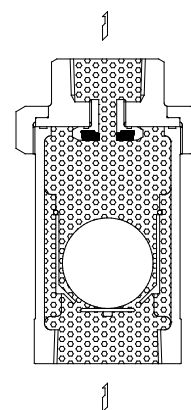

2. When discharge is completed, as water flows into the air vent, the rising water level causes the float to rise and to close the valve. If there is a rapid rise in water level (caused by rapidly opening a shut-off valve, etc.), a small amount of water may leak with discharged air immediately before the air vent closes.

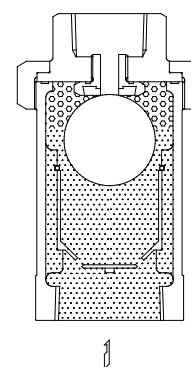

3. Once it has closed, the air vent remains closed as long as there is internal pressure.

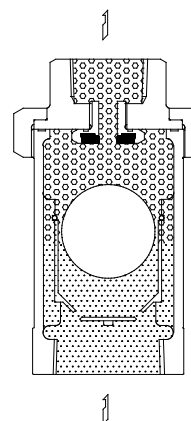

4. When draining the piping, the air vent automatically opens to introduce air and remove water more easily (preventing a vacuum from forming in the piping).

## Specifications



### WARNING

DO NOT use for toxic, flammable or otherwise hazardous fluids. This product is an air vent that discharges air from water piping system. Use only for water and/or air. This product is for intended use only. Improper use may result in such hazards as damage to the product or malfunctions that may lead to serious accident.



### CAUTION

Install properly and DO NOT use this product outside the recommended operating pressure, temperature and other specification ranges. Improper use may result in such hazards as damage to the product or malfunctions which may lead to serious accidents. Local regulations may restrict the use of this product to below the conditions quoted.



### CAUTION

Use only under conditions in which no freeze-up will occur. Freezing may damage the product, leading to fluid discharge, which may cause burns or other injury.

Refer to the product nameplate for detailed specifications.

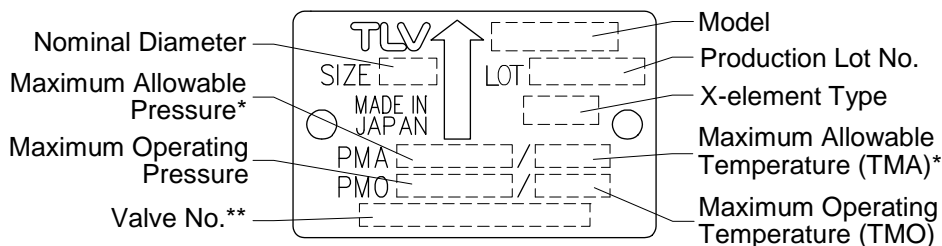

\* Maximum allowable pressure (PMA) and maximum allowable temperature (TMA) are PRESSURE SHELL DESIGN CONDITIONS, **NOT** OPERATING CONDITIONS.

\*\* Valve No. is displayed for products with options. This item is omitted from the nameplate when there are no options.

## Configuration

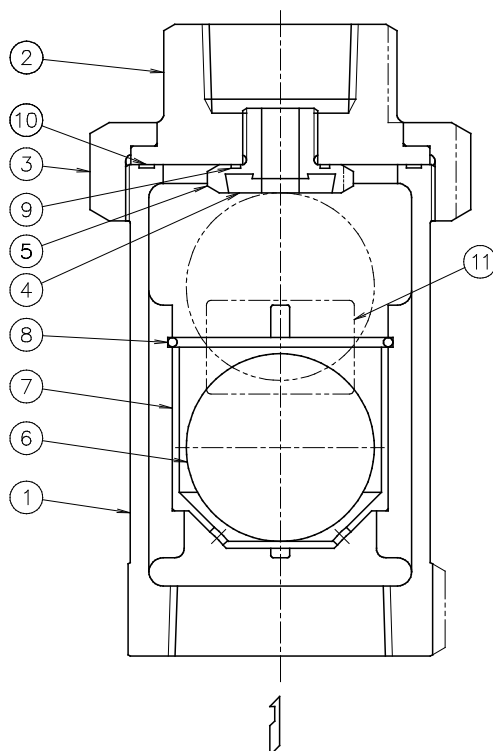

No.	Part Name
1	Body
2	Union
3	Cap Nut
4	Valve Seat
5	Valve Seat Holder
6	Float
7	Float Guide
8	Snap Ring
9	Valve Seat Gasket
10	Union Gasket
11	Nameplate

## Installation



### WARNING

DO NOT use for toxic, flammable or otherwise hazardous fluids. This product is an air vent that discharges air from water piping system. Use only for water and/or air. This product is for intended use only. Improper use may result in such hazards as damage to the product or malfunctions that may lead to serious accident.



### CAUTION

Install properly and DO NOT use this product outside the recommended operating pressure, temperature and other specification ranges. Improper use may result in such hazards as damage to the product or malfunctions which may lead to serious accidents. Local regulations may restrict the use of this product to below the conditions quoted.



### CAUTION

Take measures to prevent people from coming into direct contact with product outlets. Failure to do so may result in burns or other injury from the discharge of fluids.

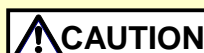

### CAUTION

Do not use excessive force when connecting threaded pipes to the product. Over-tightening may cause breakage leading to fluid discharge, which may cause burns or other injury.

Installation, inspection, maintenance, repairs, disassembly, adjustment and valve opening/closing should be carried out only by trained maintenance personnel.

1. Before installation, be sure to remove all protective seals.
2. Before installing the product, open the inlet valve and blow out the piping to remove any piping scraps, dirt and oil. Close the inlet valve after blowdown.
3. This product must be installed vertically, with the inlet at the bottom and the outlet at the top, and should be inclined no more than 5° horizontally and front-to-back (Figure 2).
4. Install the product in a location where air is likely to collect, such as a bend in the piping.
5. Install the product so that the outlet pipe reaches a drainage vessel or ditch. Make sure the end of the pipe is above the waterline, so that dirt and water can not be sucked up by vacuum when the system shuts down (Figure 1).
6. Inlet piping with no horizontal portion is recommended for water/air displacement. If there is a horizontal portion, make the pipe diameter of the horizontal portion larger than the vertical portion or make the horizontal portion as short as possible.
7. Make sure the inlet piping diameter is at least as large as the product's inlet diameter.
8. Installation of an isolation valve just before the product's main connection is recommended as it enables maintenance during operation. A full-bore ball valve is recommended.
9. Make sure to take measures to prevent foreign matter from flowing into the product.
10. This is a rapid initial air vent for quickly venting large amounts of air at startup only. If air venting is necessary during system operation, install an automatic air vent as well.

If there is a problem, determine the cause using the "Troubleshooting" section in this manual.

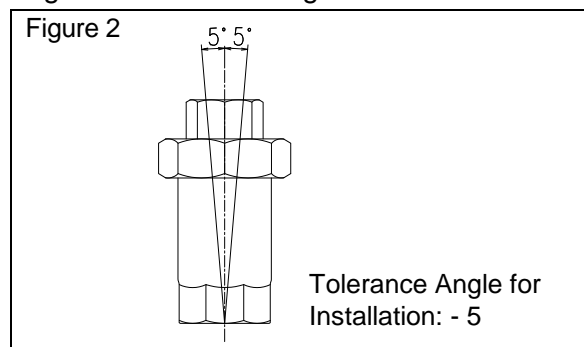
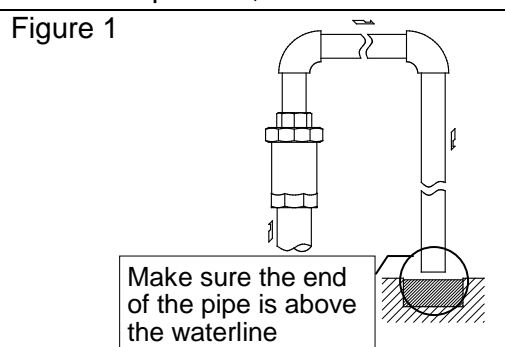

## Maintenance



Take measures to prevent people from coming into direct contact with product outlets. Failure to do so may result in burns or other injury from the discharge of fluids.



Be sure to use only the recommended components when repairing the product, and NEVER attempt to modify the product in any way. Failure to observe these precautions may result in damage to the product or burns or other injury due to malfunction or the discharge of fluids.

## Operational Check

A visual inspection of the following items should be done on a daily basis to determine whether the air vent is operating properly or has failed.

If the air vent should fail, it may cause water leakage or hindrance to water flow.

Normal : Air is discharged as it accumulates, with the air vent closing (with no leakage) when no air is present in the piping.

Blocked (Discharge Impossible) : No air is discharged though air accumulates in the air vent.

NOTE: Once the air vent closes, it will remain closed until internal pressure drops to near or below atmospheric pressure. This condition may be confused with a malfunction (blocked). If air is expected to accumulate in the piping during operation, use together with an automatic air vent.

Leakage : Water is discharged or leaks through the air vent outlet during closed position.

## Parts Inspection

When parts have been removed, or during periodic inspections, use the following table to inspect the parts and replace any that are found to be defective.

Procedure	
Gaskets:	check for warping or scratches
Valve Seat Surface:	check for scratches or wear
Float:	check for scratches or dents
Float Guide:	check for deformation



## Disassembly/Reassembly



### WARNING

NEVER apply direct heat to the float. The float may explode due to increased internal pressure, causing accidents leading to serious injury or damage to property and equipment.



### CAUTION

When disassembling or removing the product, wait until the internal pressure equals atmospheric pressure and the surface of the product has cooled to room temperature. Disassembling or removing the product when it is hot or under pressure may lead to discharge of fluids, causing burns, other injuries or damage.



### CAUTION

Be sure to use only the recommended components when repairing the product, and NEVER attempt to modify the product in any way. Failure to observe these precautions may result in damage to the product or burns or other injury due to malfunction or the discharge of fluids.

## Disassembly/Reassembly

Use the following procedures to remove components. Use the same procedures in reverse to reassemble. (Installation, inspection, maintenance, repairs, disassembly, adjustment and valve opening/closing should be carried out only by trained maintenance personnel.)

Part	During Disassembly	During Reassembly
Cap Nut	Remove with a wrench	Consult the table of tightening torques and tighten to the proper torque
Union	Remove, being careful not to scratch the gasket sealing surface	Make sure there are no pieces of the old gasket left on the sealing surfaces and reattach
Union Gasket	Remove carefully, being careful not to scratch the sealing surfaces	Replace with a new gasket if damaged; make sure there are no pieces of the old gasket left on the sealing surfaces of the body
Valve Seat/ Valve Seat Holder	Remove with a socket wrench	Replace with a new valve seat / valve seat holder if misshapen or damaged Consult the table of tightening torques and tighten to the proper torque
Valve Seat Gasket	Remove if damaged	Replace with a new gasket if damaged
Float	Remove, being careful not to scratch the polished surface	Insert, being careful not to scratch or misshape
Snap Ring	Remove with appropriate pliers	Insert securely into the groove
Float Guide	Remove without misshaping	Insert, being careful not to misshape

### Table of Tightening Torques

VAS Size Inlet / Outlet mm (in)	Part Name	Torque		Distance Across Flats	
		N·m	(lbf·ft)	mm	(in)
20 ( <sup>3</sup> / <sub>4</sub> ) / 15 ( <sup>1</sup> / <sub>2</sub> )	Cap Nut	50	(37)	55	(2 <sup>5</sup> / <sub>32</sub> )
	Valve Seat Holder	20	(15)	17	( <sup>2</sup> / <sub>32</sub> )
40 (1 <sup>1</sup> / <sub>2</sub> ) / 25 (1)	Cap Nut	80	(59)	75	(2 <sup>15</sup> / <sub>16</sub> )
	Valve Seat Holder	35	(26)	27	(1 <sup>1</sup> / <sub>16</sub> )

(1 N·m ≈ 10 kg·cm)

NOTE: - Coat all threaded portions with anti-seize.

- If drawings or other special documentation were supplied for the product, any torque given there takes precedence over values shown here.

### Exploded View

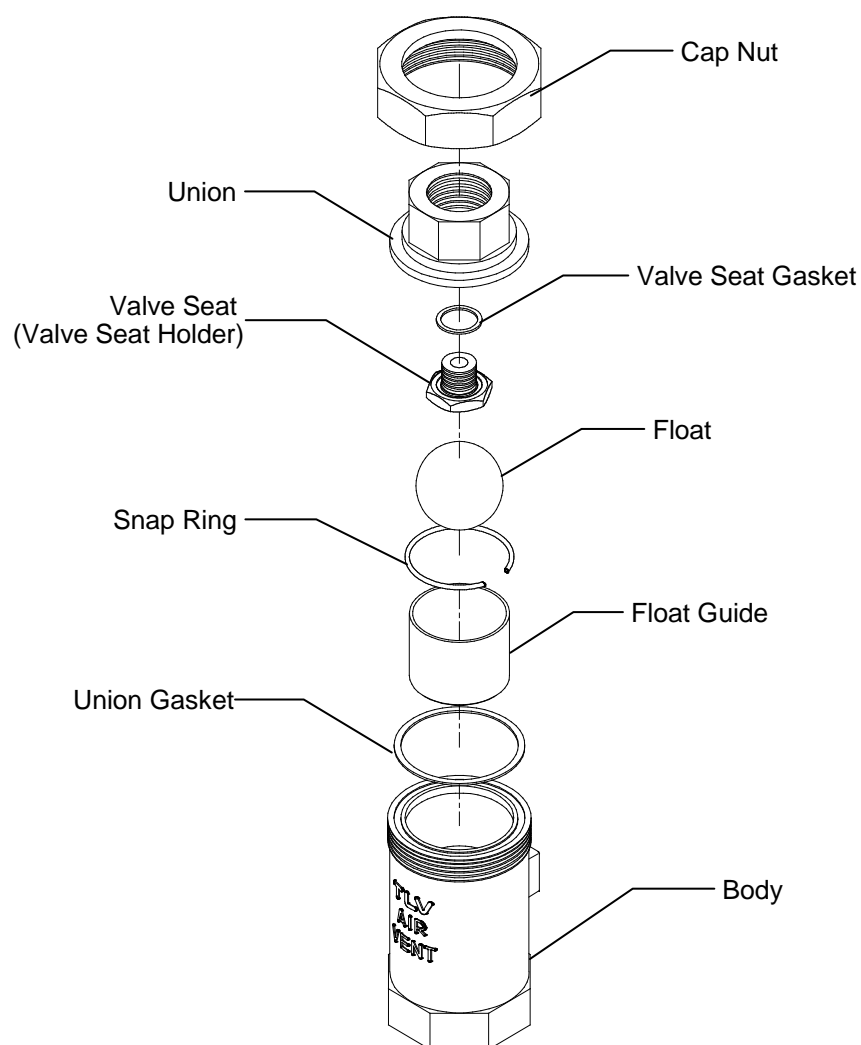

## Troubleshooting



### WARNING

NEVER apply direct heat to the float. The float may explode due to increased internal pressure, causing accidents leading to serious injury or damage to property and equipment.



### CAUTION

When disassembling or removing the product, wait until the internal pressure equals atmospheric pressure and the surface of the product has cooled to room temperature. Disassembling or removing the product when it is hot or under pressure may lead to discharge of fluids, causing burns, other injuries or damage.

When the product fails to operate properly, use the following table to locate and remedy the cause.

Problem	Cause	Remedy
No initial air is discharged (blocked)* or discharge is poor	The trapped air cannot displace the water in the piping	Correct the inlet piping
	The valve seat is clogged with dirt or foreign matter	Clean the valve seat
	The inlet or outlet piping is clogged	Clean the piping
Water leaks when the vent is closed	There is a build-up of rust or scale on the valve seat or the valve seat is damaged	Clean the valve seat or replace with a new valve seat
	The float is misshapen, dirty or has a film build-up	Clean the float or replace with a new float
	The installation angle of inclination is incorrect	Correct the installation
The vent does not close, and water is blowing	The float is damaged or filled with water	Replace with a new float
	The specific gravity of the liquid is outside the specifications for this product (This product is for water system)	Select a product with suitable specifications for the operating conditions

\* NOTE: Once the air vent closes, it will remain closed until internal pressure drops to near or below atmospheric pressure. This condition may be confused with a malfunction (blocked). If air is expected to accumulate in the piping during operation, use together with an automatic air vent.

## Product Warranty

1. Warranty Period  
One year following product delivery.
2. Warranty Coverage  
TLV CO., LTD. warrants this product to the original purchaser to be free from defective materials and workmanship. Under this warranty, the product will be repaired or replaced at our option, without charge for parts or labor.
3. This product warranty will not apply to cosmetic defects, nor to any product whose exterior has been damaged or defaced; nor does it apply in the following cases:
  - 1) Malfunctions due to improper installation, use, handling, etc., by other than TLV CO., LTD. authorized service representatives.
  - 2) Malfunctions due to dirt, scale, rust, etc.
  - 3) Malfunctions due to improper disassembly and reassembly, or inadequate inspection and maintenance by other than TLV CO., LTD. authorized service representatives.
  - 4) Malfunctions due to disasters or forces of nature.
  - 5) Accidents or malfunctions due to any other cause beyond the control of TLV CO., LTD.
4. Under no circumstances will TLV CO., LTD. be liable for consequential economic loss damage or consequential damage to property.

\* \* \* \* \*

For Service or Technical Assistance:

Contact your **TLV** representative or your regional **TLV** office.

### Manufacturer

**TLV** CO., LTD.  
881 Nagasuna, Noguchi  
Kakogawa, Hyogo 675-8511 JAPAN  
Tel: 81-(0)79 - 427 - 1800