



Instruction Manual

Free Float Steam Trap with X-Element

FJ32D-X

QuickTrap®

J32D-X

Trap Unit

Contents

Introduction	1
Safety Considerations	2
Checking the Piping	4
Operation	5
Specifications	6
Compatibility	6
Configuration	7
Installation	8
Maintenance	10
Disassembly/Reassembly	11
Instructions for Plug/Holder Disassembly and Reassembly...	14
Troubleshooting	15
TLV EXPRESS LIMITED WARRANTY	16
Service	18
Options	19

Introduction

Thank you for purchasing the TLV free float steam trap.

This product has been thoroughly inspected before being shipped from the factory. When the product is delivered, before doing anything else, check the specifications and external appearance to make sure nothing is out of the ordinary. Also be sure to read this manual carefully before use and follow the instructions to be sure of using the product properly.

This free float steam trap uses a two-bolt flange, an X-element air vent and three-point seating for a precision-ground float, increasing heating efficiency and reducing manpower requirements for maintenance.

The two-bolt flange allows the trap to be installed in either horizontal or vertical piping. This flexibility greatly reduces the time required for installation, removal, repair and maintenance. The three-point seating supports the precision-ground float securely and ensures a high degree of sealing for even minute quantities of condensate. The X-element is very sensitive to changes in temperature, and responds with great accuracy, quickly discharging air and the large quantities of condensate created immediately after operation startup, thereby greatly reducing start-up time. It also reacts with great sensitivity to the inflow of large quantities of condensate and hot air during operation, preventing air binding.







If detailed instructions for special order specifications or options not contained in this manual are required, please contact TLV for full details.

This instruction manual is intended for use with the model(s) listed on the front cover. It is necessary not only for installation, but for subsequent maintenance, disassembly/reassembly and troubleshooting. Please keep it in a safe place for future reference.

Safety Considerations

- Read this section carefully before use and be sure to follow the instructions.
- Installation, inspection, maintenance, repairs, disassembly, adjustment and valve opening/closing should be carried out only by trained maintenance personnel.
- The precautions listed in this manual are designed to ensure safety and prevent equipment damage and personal injury. For situations that may occur as a result of erroneous handling, three different types of cautionary items are used to indicate the degree of urgency and the scale of potential damage and danger: DANGER, WARNING and CAUTION.
- The three types of cautionary items above are very important for safety: be sure to observe all of them as they relate to installation, use, maintenance and repair. Furthermore, TLV accepts no responsibility for any accidents or damage occurring as a result of failure to observe these precautions.

Symbols

	Indicates a DANGER, WARNING or CAUTION item.
 DANGER	Indicates an urgent situation which poses a threat of death or serious injury
 WARNING	Indicates that there is a potential threat of death or serious injury
 CAUTION	Indicates that there is a possibility of injury or equipment/product damage
 WARNING	NEVER apply direct heat to the float. The float may explode due to increased internal pressure, causing accidents leading to serious injury or damage to property and equipment.
 CAUTION	Install properly and DO NOT use this product outside the recommended operating pressure, temperature and other specification ranges. Improper use may result in such hazards as damage to the product or malfunctions that may lead to serious accidents. Local regulations may restrict the use of this product to below the conditions quoted.
	DO NOT use this product in excess of the maximum operating pressure differential. Such use could make discharge impossible (blocked).
	Take measures to prevent people from coming into direct contact with product outlets. Failure to do so may result in burns or other injury from the discharge of fluids.
	When disassembling or removing the product, wait until the internal pressure equals atmospheric pressure and the surface of the product has cooled to room temperature. Disassembling or removing the product when it is hot or under pressure may lead to discharge of fluids, causing burns, other injuries or damage.

Continued on the next page

 CAUTION	<p>Be sure to use only the recommended components when repairing the product, and NEVER attempt to modify the product in any way. Failure to observe these precautions may result in damage to the product and burns or other injury due to malfunction or the discharge of fluids.</p> <p>Use only under conditions in which no freeze-up will occur. Freezing may damage the product, leading to fluid discharge, which may cause burns or other injury.</p> <p>Use only under conditions in which no water hammer will occur. The impact of water hammer may damage the product, leading to fluid discharge, which may cause burns or other injury.</p>
--	---

Checking the Piping



Use only under conditions in which no water hammer will occur. The impact of water hammer may damage the product, leading to fluid discharge, which may cause burns or other injury.

Check to make sure that the pipes to be connected to the product have been installed properly.

1. Is the pipe diameter suitable?
2. Is the trap unit installed horizontally?
3. Has sufficient space been secured for maintenance?
4. Have isolation valves been installed at the inlet and outlet? If the outlet is subject to back pressure, has a check valve (TLV-CK) been installed?
5. Is the inlet pipe as short as possible, with as few bends as possible, and installed so the liquid will flow naturally down into the product?
6. Has the piping work been done correctly, as shown in the figures below?
7. Using the appropriate tools, have the screws been tightened enough?

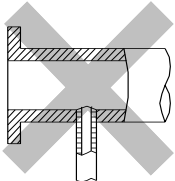
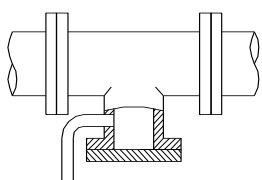
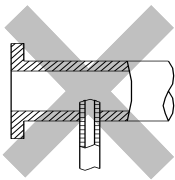
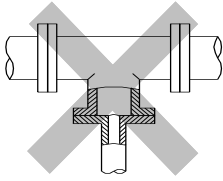
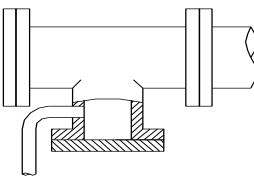
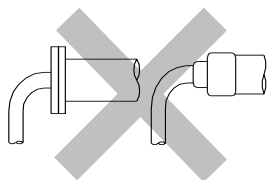
Requirement	Correct	Incorrect
Install catchpot with the proper diameter.		 <p>Diameter is too small.</p>
Make sure the flow of condensate is not obstructed.		 <p>Diameter is too small and inlet protrudes into pipe interior.</p>
To prevent rust and scale from flowing into the trap, the inlet pipe should be connected 25 to 50 mm (1 to 2 in) above the base of the T-pipe.		 <p>Rust and scale flow into the trap with the condensate.</p>
When installing on the blind end, make sure the flow of condensate is not obstructed.		 <p>Condensate collects in the pipe.</p>

Operation

Principles of air and condensate discharge:

1. Air and Cold Condensate Discharge at Startup

At startup, before steam is supplied, the trap is cold, the X-element is contracted and the air vent valve seat (A) is open. This allows for the rapid discharge of air through the air vent valve (A) and cold condensate through the orifice (B) opening, when steam is first supplied to the system.

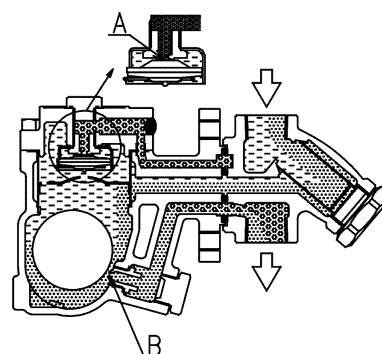

2. Condensate Discharge

After the discharge of initial air and cold condensate, the heat of the inflowing steam and condensate causes the X-element to expand, closing the air vent valve (A). The rising condensate level causes the float to rise due to buoyancy, opening the orifice (B) and allowing condensate to be discharged.

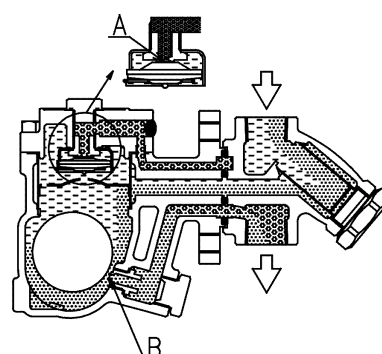

3. Hot Air Discharge

Should hot air flow into the trap with the steam during normal operation, the temperature of the X-element drops, causing it to momentarily contract and open the air vent valve (A), which allows for the rapid discharge of the air. After the air is discharged and steam contacts the X-element, the temperature will increase causing the air vent valve (A) to close.

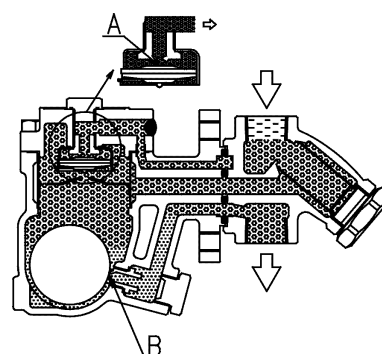

4. Closed Position

When the condensate flow rate decreases, the float falls as condensate is discharged, closing the orifice (B). A water seal is maintained at all times over the orifice (B) to prevent steam loss.

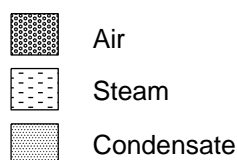
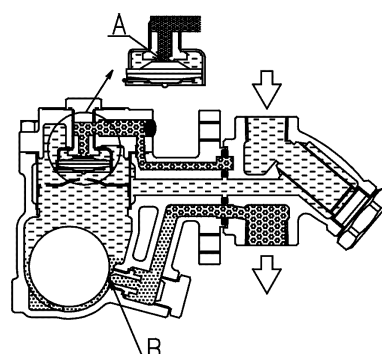

Specifications

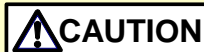

Install properly and **DO NOT** use this product outside the recommended operating pressure, temperature and other specification ranges. Improper use may result in such hazards as damage to the product or malfunctions which may lead to serious accidents. Local regulations may restrict the use of this product to below the conditions quoted.



DO NOT use this product in excess of the maximum operating pressure differential; such use could make discharge impossible (blocked).



Use only under conditions in which no freeze-up will occur. Freezing may damage the product, leading to fluid discharge, which may cause burns or other injury.

Refer to the product nameplate for detailed specifications.

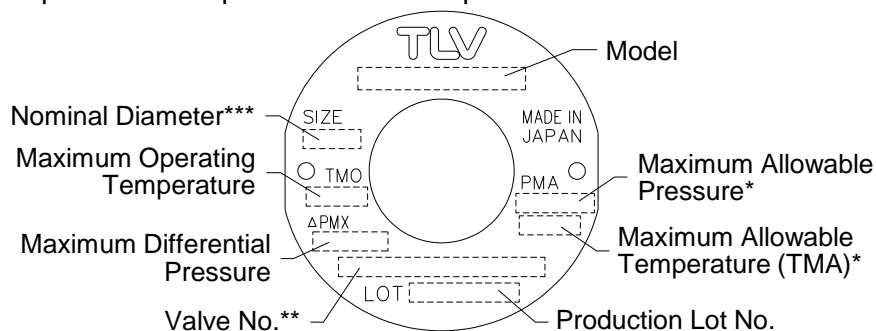

*Maximum allowable pressure (PMA) and maximum allowable temperature (TMA) are PRESSURE SHELL DESIGN CONDITIONS, **NOT** OPERATING CONDITIONS.

**Valve No. is displayed for products with options. This item is omitted from the nameplate when there are no options.

***The nominal diameter is not printed on the trap unit nameplate when the trap unit is shipped by itself.

Compatibility

- The FJ32 QuickTrap series employ a unique **TLV** connector unit (F46J) and are not compatible with QuickTraps using connector unit F32 or others.
- Trap and connector units must only be used with compatible models.

The unit name is embossed on the connector body.

Configuration

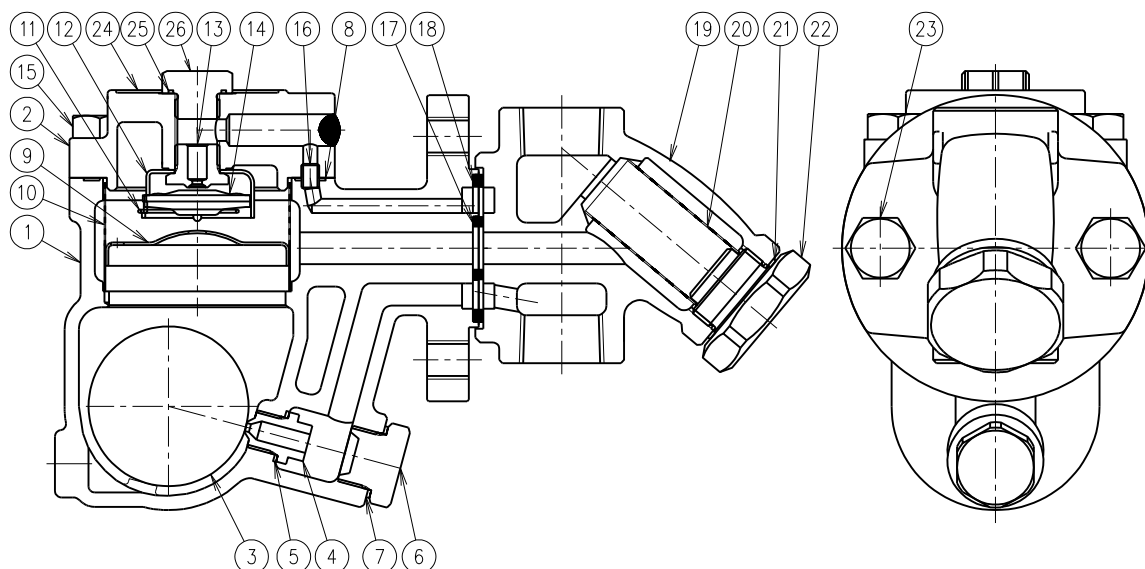

No.	Name	T	C	M	R	F	No.	Name	T	C	M	R	F
1	Body	✓					14	X-element	✓			✓	
2	Cover	✓					15	Cover Bolt	✓				
3	Float	✓				✓	16	Connector	✓				
4	Orifice	✓			✓		17	Inner Connector Gasket	✓		✓	✓	
5	Orifice Gasket	✓		✓	✓		18	Outer Connector Gasket	✓		✓	✓	
6	Orifice Plug	✓					19	Connector Body		✓			
7	Orifice Plug Gasket	✓		✓	✓		20	Screen		✓		✓	
8	Cover Gasket	✓		✓	✓		21	Screen Holder Gasket		✓	✓	✓	
9	Float Cover	✓			✓		22	Screen Holder		✓			
10	Screen	✓			✓		23	Connector Bolt	✓				
11	Spring Clip	✓			✓		24	Nameplate	✓				
12	X-element Guide	✓			✓		25	Plug Gasket	✓		✓	✓	
13	Air Vent Valve Seat	✓			✓		26	Plug	✓				

*Replacement parts are available only in the following kits:

T = Trap unit: J32D-X

C = Connector body: F46J

M = Maintenance kit

R = Repair kit

F = Float

Installation



Install properly and **DO NOT** use this product outside the recommended operating pressure, temperature and other specification ranges. Improper use may result in such hazards as damage to the product or malfunctions which may lead to serious accidents. Local regulations may restrict the use of this product to below the conditions quoted.

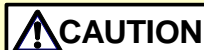

Take measures to prevent people from coming into direct contact with product outlets. Failure to do so may result in burns or other injury from the discharge of fluids.

Installation, inspection, maintenance, repairs, disassembly, adjustment and valve opening/closing should be carried out only by trained maintenance personnel.

1. Before installation, be sure to remove all protective seals.
2. Before installing the product, blow out the inlet piping to remove any piping scraps, dirt and oil. Close the inlet valve after blowdown.
3. Install the connector body so that the arrow is pointing in the direction of flow.
4. The connector body has no restrictions on installation orientation except for the following conditions: the flange face (for connecting to the trap unit) must be in the vertical plane, and the trap unit must be installed with the nameplate facing upwards.
5. The trap unit must be inclined no more than 5° horizontally and front-to-back.
6. Install a condensate outlet valve and outlet piping.
7. Open the inlet and outlet valves and ensure that the product functions properly.

If there is a problem, determine the cause using the “Troubleshooting” section in this manual.

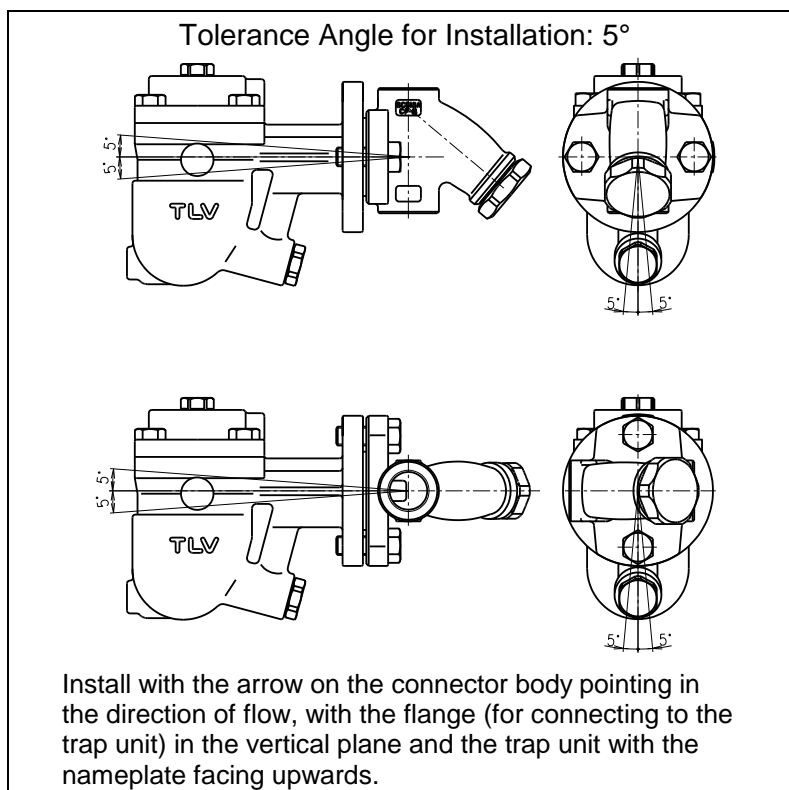

Installation Examples: Horizontal Piping

Correct	Incorrect			
	Nameplate is not facing upwards		Connector Flange is not in the vertical plane	

Installation Examples: Vertical Piping

Correct	Incorrect	
	Nameplate is not facing upwards.	

Note for Screwed Connection:

When products with screwed connections are installed on horizontal piping, there is a danger that the weight of the trap unit will cause the connector body to rotate on the pipe, putting the trap mechanism out of the horizontal plane. To prevent this, tighten the screws securely. In cases where the product is affected by vibrations or by external contact, it is recommended that the trap unit should be supported to prevent rotation (sample support shown to the right).

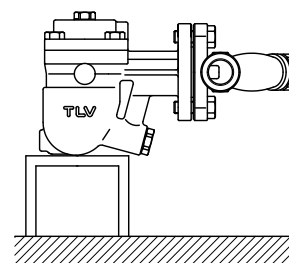

Maintenance



Take measures to prevent people from coming into direct contact with product outlets. Failure to do so may result in burns or other injury from the discharge of fluids.



Be sure to use only the recommended components when repairing the product, and NEVER attempt to modify the product in any way. Failure to observe these precautions may result in damage to the product or burns or other injury due to malfunction or the discharge of fluids.

Operational Check

A visual inspection of the following items should be done on a daily basis to determine whether the product is operating properly or has failed. Periodically (at least biannually) the operation should also be checked by using diagnostic equipment such as a stethoscope, thermometer, TLV Pocket TrapMan or TrapMan.

If the product should fail, it may cause damage to piping and equipment, resulting in faulty or low quality products or losses due to steam leakage.

Normal:	Condensate is discharged continuously, together with flash steam, and the sound of flow can be heard. If there is very little condensate, there is almost no sound of flow.
Blocked: (Discharge Impossible)	No condensate is discharged. The product is quiet and makes no noise, and the surface temperature of the product is low.
Blowing:	Live steam continually flows from the outlet and there is a continuous metallic sound.
Steam Leakage:	Live steam is discharged through the trap outlet together with condensate, accompanied by a high-pitched sound.

(When conducting a visual inspection, flash steam is sometimes mistaken for steam leakage. For this reason, the use of a steam trap diagnostic instrument - such as TLV TrapMan - in conjunction with the visual inspection is highly recommended.)

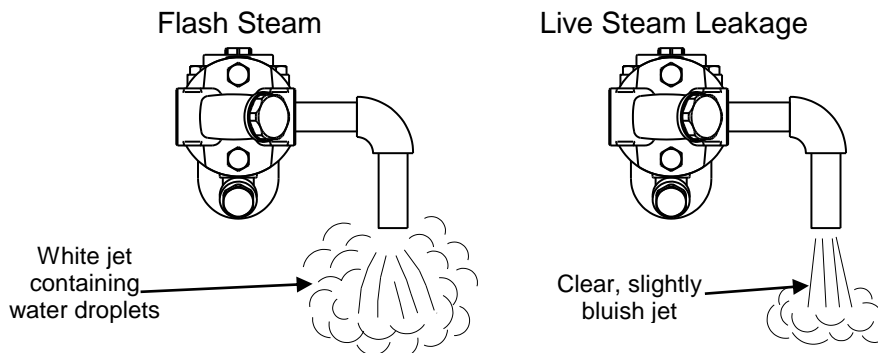

Parts Inspection

When parts have been removed, or during periodic inspections, use the following table to inspect the parts and replace any that are found to be defective.

Procedure	
Gaskets:	Check for warping or scratches
Screens:	Check for clogging or corrosion
X-element:	Check for scratches
Air Vent Valve Seat:	Check for scratches
Float:	Check for scratches or dents
Body Interior:	Check for build-up
Orifice Opening:	Check for dirt, oil film, wear or scratches

Disassembly/Reassembly



NEVER apply direct heat to the float. The float may explode due to increased internal pressure, causing accidents leading to serious injury or damage to property and equipment.



When disassembling or removing the product, wait until the internal pressure equals atmospheric pressure and the surface of the product has cooled to room temperature. Disassembling or removing the product when it is hot or under pressure may lead to discharge of fluids, causing burns, other injuries or damage.

Use the following procedures to remove components. Use the same procedures in reverse to reassemble.

(Installation, inspection, maintenance, repairs, disassembly, adjustment and valve opening/closing should be carried out only by trained maintenance personnel.)

Detaching/Reattaching the Trap Unit and Connector Body

Part	During Disassembly	During Reassembly
Connector Bolts	Remove with a socket wrench	Consult the table of tightening torques and tighten to the proper torque
Trap Unit	Remove the trap unit	Follow the special instructions below (see fig. A)
Connector Gaskets	Remove the gasket with a flat-head screwdriver and clean sealing surfaces	Replace with new gaskets. To facilitate assembly and prevent loosening of the gaskets, apply a small amount of adhesive at 120° intervals around the outer edge of the gaskets

Attaching the Trap Unit to the Connector Body (Figure A)

1. If attaching a new trap unit, be sure to remove the protective cap from the connector flange. Be careful not to drop the gaskets when removing the cap.
2. Grasp the end of the trap unit and align its gasket housing with the indentation on the connector body.
3. Once aligned, insert and finger tighten the connector bolts. Verify that the trap unit is within the allowable inclination.

Figure A

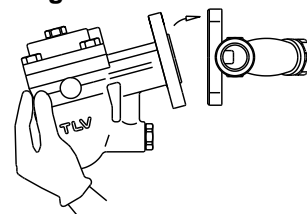

Detaching/Reattaching the Cover

Part	During Disassembly	During Reassembly
Cover Bolt	Remove with a socket wrench	Consult the table of tightening torques and tighten to the proper torque
Cover	Remove by lifting up and off	Make sure there are no pieces of the old gasket on the sealing surfaces, align the cover with the body and connector and reattach
Connector	Remove the connector	Reinsert it into hole in body
Cover Gasket	Remove the gasket	Replace with a new gasket

Disassembly/Reassembly of Components Inside the Cover

Part	During Disassembly	During Reassembly
Snap Ring	Pinch the insides together and remove from the X-element guide	Insert securely into the groove in the guide
X-element	Remove from the X-element guide	Insert and ensure correct orientation (Figure B)
Air Vent Valve Seat	Remove with a socket wrench	Consult the table of tightening torques and tighten to the proper torque
X-element Guide	Remove without bending	Insert the X-element gently

Figure B

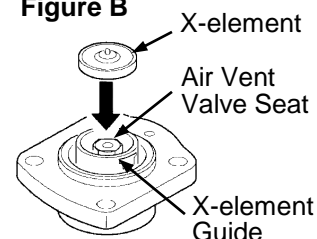

Disassembly/Reassembly of Components Inside the Trap Body

Part	During Disassembly	During Reassembly
Float Cover & Screen	Lift straight up and out while rocking slowly	Align the arrows on the float cover/screen and the body, insert with the tab on the bottom fitting into the slot in the body; make sure the screen does not stick out out of the body (Figure C)
Float	Remove, being careful not to scratch the surface	Insert, being careful not to scratch the surface
Orifice Plug	Remove with a socket wrench	Consult the table of tightening torques and tighten to the proper torque
Orifice Plug Gasket	Remove the gasket	Replace with a new gasket; coat surfaces with anti-seize
Orifice	Remove with a socket wrench	Consult the table of tightening torques and tighten to the proper torque
Orifice Gasket	Remove the gasket	Replace with a new gasket; coat surfaces with anti-seize

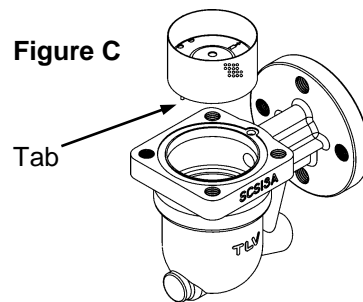

Disassembly/Reassembly of Components Inside the Connector Body

Part	During Disassembly	During Reassembly
Screen Holder	Remove with a socket wrench	Consult the table of tightening torques and tighten to the proper torque
Screen Holder Gasket	Remove the gasket	Replace with new gasket; coat surfaces with anti-seize
Screen	Remove with needle-nose pliers	Insert securely into the connector body

Table of Tightening Torques

Part Name	Torque		Distance Across Flats	
	N·m	(lbf·ft)	N·m	(in)
Orifice	30	(22)	10	(³ / ₈)
Orifice Plug	80	(59)	24	(¹⁵ / ₁₆)
Air Vent Valve Seat	35	(26)	19	(³ / ₄)
Cover Bolt	50	(37)	17	(²¹ / ₃₂)
Screen Holder	150	(110)	38	(1 ¹ / ₂)
Bolt (Trap Body/Connector Body)	80	(59)	19	(³ / ₄)
Cover Plug	30	(22)	19	(³ / ₄)

NOTE: -Coat all threaded portions with anti-seize. (1 N·m ≈ 10 kg·cm)

-If drawings or other special documentation were supplied for the product, any torque given there takes precedence over values shown here.

Exploded View

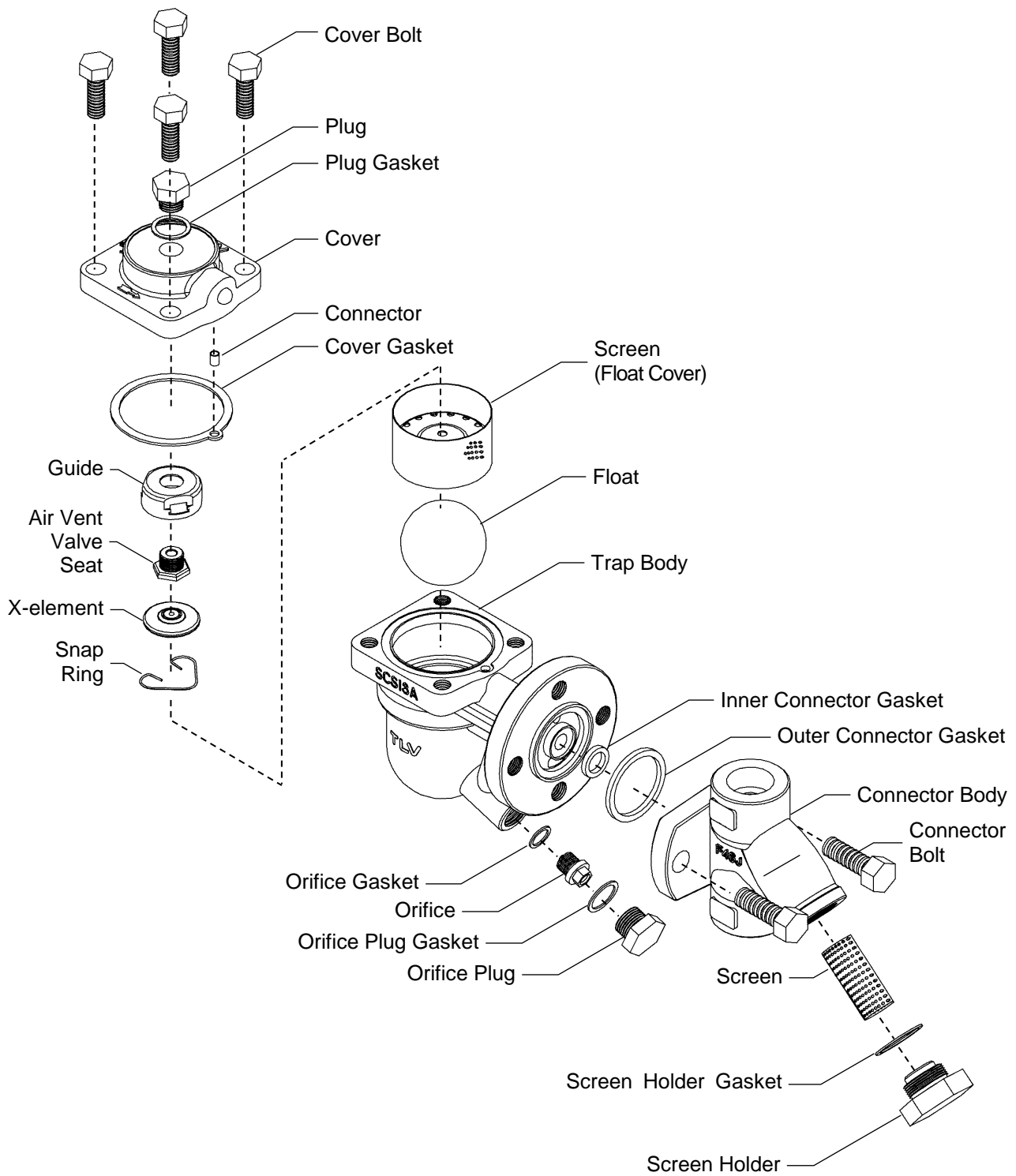

Instructions for Plug/Holder Disassembly and Reassembly

The seal on the threaded plugs/holders found on TLV products is formed by a flat metal gasket. There are various installation orientations for the gaskets, such as horizontal, diagonal and downward, and the gasket may be pinched in the thread recesses during assembly.

Instructions for Disassembly and Reassembly

- ① Remove the plug/holder using a tool of the specified size (distance across flats).
- ② The gasket should not be reused. Be sure to replace it with a new gasket.
- ③ Clean the gasket surfaces of the plug/holder and the product body using a rag and/or cleaning agents, then check to make sure the surfaces are not scratched or deformed.
- ④ Coat both the gasket surface of the plug/holder and the threads of the plug/holder with anti-seize, then press the gasket onto the center of the gasket surface of the plug/holder, making sure the anti-seize affixes the gasket tightly to the plug/holder. Check to make sure the gasket is not caught in the recesses of the threads.
- ⑤ Hold the plug/holder upside down to make sure that the anti-seize makes the gasket stick to the plug/holder even when the plug/holder is held upside down.
- ⑥ Screw the plug/holder by hand into the product body while making sure that the gasket remains tightly affixed to the center of the gasket surface of the plug/holder. Make sure the entire gasket is making contact with the gasket surface of the product body. It is important at this point to make sure the gasket is not pinched in the thread recesses of the plug/holder.
- ⑦ Tighten the plug/holder to the proper torque.
- ⑧ Next, begin the supply of steam and check to make sure there is no leakage from the part just tightened. If there is leakage, immediately close the inlet valve and, if there is a bypass valve, take the necessary steps to release any residual pressure. After the surface of the product cools to room temperature, repeat the procedure beginning from step 1.

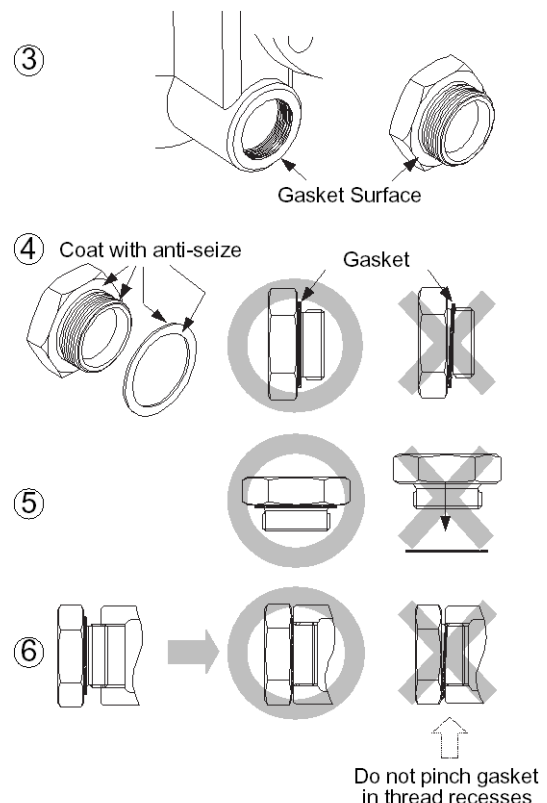

Troubleshooting



When disassembling or removing the product, wait until the internal pressure equals atmospheric pressure and the surface of the product has cooled to room temperature. Disassembling or removing the product when it is hot or under pressure may lead to discharge of fluids, causing burns, other injuries or damage.

If the product fails to operate properly, use the following table to locate the cause and remedy.

Problem	Cause	Remedy
No condensate is discharged (blocked) or discharge is poor	The float is damaged or filled with condensate	Replace with a new float
	The orifice opening, screen or piping are clogged with rust and scale	Clean parts
	The X-element is scratched or damaged	Replace with a new X-element
	The product operating pressure exceeds the maximum specified pressure or there is insufficient pressure differential between the product inlet and outlet	Compare specifications and actual operating conditions
	Steam locking has occurred	Perform a bypass blowdown or close the trap inlet valve and allow the trap to cool
Steam is discharged or leaks from the outlet (blowing) (steam leakage)	Build-up on the seating surface of the orifice or rust and scale build-up beneath the float	Clean parts
	Scratches on the orifice	Replace with a new orifice
	The float is misshapen or has surface build-up	Clean or replace with a new float
	Improper installation	Correct the installation
	The X-element air vent valve seating and/or air vent valve seat are scratched or have surface build-up	Clean or replace with a new X-element / air vent valve seat
	Trap vibration	Lengthen the inlet piping and fasten it securely
Steam is leaking from a place other than the outlet	Gasket deterioration or damage	Replace with a new gasket
	Improper tightening torques were used	Tighten to the proper torque
Float frequently becomes damaged	Water hammer has occurred	Study and correct the piping

NOTE: When replacing parts with new, use the parts list for reference, and replace with parts from the maintenance kit, repair kit, etc. Please note that replacement parts are only available as part of a replacement parts kit.

TLV EXPRESS LIMITED WARRANTY

Subject to the limitations set forth below, TLV CO., LTD., a Japanese corporation (“**TLV**”), warrants that products which are sold by it, TLV International Inc. (“**TII**”) or one of its group companies excluding TLV Corporation (a corporation of the United States of America), (hereinafter the “**Products**”) are designed and manufactured by TLV, conform to the specifications published by TLV for the corresponding part numbers (the “**Specifications**”) and are free from defective workmanship and materials. The party from whom the Products were purchased shall be known hereinafter as the “**Seller**”. With regard to products or components manufactured by unrelated third parties (the “**Components**”), TLV provides no warranty other than the warranty from the third party manufacturer(s), if any.

Exceptions to Warranty

This warranty does not cover defects or failures caused by:

1. improper shipping, installation, use, handling, etc., by persons other than TLV, TII or TLV group company personnel, or service representatives authorized by TLV; or
2. dirt, scale or rust, etc.; or
3. improper disassembly and reassembly, or inadequate inspection and maintenance by persons other than TLV or TLV group company personnel, or service representatives authorized by TLV; or
4. disasters or forces of nature or Acts of God; or
5. abuse, abnormal use, accidents or any other cause beyond the control of TLV, TII or TLV group companies; or
6. improper storage, maintenance or repair; or
7. operation of the Products not in accordance with instructions issued with the Products or with accepted industry practices; or
8. use for a purpose or in a manner for which the Products were not intended; or
9. use of the Products in a manner inconsistent with the Specifications; or
10. use of the Products with Hazardous Fluids (fluids other than steam, air, water, nitrogen, carbon dioxide and inert gases (helium, neon, argon, krypton, xenon and radon)); or
11. failure to follow the instructions contained in the TLV Instruction Manual for the Product.

Duration of Warranty

This warranty is effective for a period of one (1) year after delivery of Products to the first end user. Notwithstanding the foregoing, asserting a claim under this warranty must be brought within three (3) years after the date of delivery to the initial buyer if not sold initially to the first end user.

ANY IMPLIED WARRANTIES NOT NEGATED HEREBY WHICH MAY ARISE BY OPERATION OF LAW, INCLUDING THE IMPLIED WARRANTIES OF MERCHANTABILITY AND FITNESS FOR A PARTICULAR PURPOSE AND ANY EXPRESS WARRANTIES NOT NEGATED HEREBY, ARE GIVEN SOLELY TO THE INITIAL BUYER AND ARE LIMITED IN DURATION TO ONE (1) YEAR FROM THE DATE OF SHIPMENT BY THE SELLER.

Exclusive Remedy

THE EXCLUSIVE REMEDY UNDER THIS WARRANTY, UNDER ANY EXPRESS WARRANTY OR UNDER ANY IMPLIED WARRANTIES NOT NEGATED HEREBY (INCLUDING THE IMPLIED WARRANTIES OF MERCHANTABILITY AND FITNESS FOR A PARTICULAR PURPOSE), IS **REPLACEMENT**; PROVIDED: (a) THE CLAIMED DEFECT IS REPORTED TO THE SELLER IN WRITING WITHIN THE WARRANTY PERIOD, INCLUDING A DETAILED WRITTEN

DESCRIPTION OF THE CLAIMED DEFECT AND HOW AND WHEN THE CLAIMED DEFECTIVE PRODUCT WAS USED; AND (b) THE CLAIMED DEFECTIVE PRODUCT AND A COPY OF THE PURCHASE INVOICE IS RETURNED TO THE SELLER, FREIGHT AND TRANSPORTATION COSTS PREPAID, UNDER A RETURN MATERIAL AUTHORIZATION AND TRACKING NUMBER ISSUED BY THE SELLER. ALL LABOR COSTS, SHIPPING COSTS, AND TRANSPORTATION COSTS ASSOCIATED WITH THE RETURN OR REPLACEMENT OF THE CLAIMED DEFECTIVE PRODUCT ARE SOLELY THE RESPONSIBILITY OF BUYER OR THE FIRST END USER. THE SELLER RESERVES THE RIGHT TO INSPECT ON THE FIRST END USER'S SITE ANY PRODUCTS CLAIMED TO BE DEFECTIVE BEFORE ISSUING A RETURN MATERIAL AUTHORIZATION. SHOULD SUCH INSPECTION REVEAL, IN THE SELLER'S REASONABLE DISCRETION, THAT THE CLAIMED DEFECT IS NOT COVERED BY THIS WARRANTY, THE PARTY ASSERTING THIS WARRANTY SHALL PAY THE SELLER FOR THE TIME AND EXPENSES RELATED TO SUCH ON-SITE INSPECTION.

Exclusion of Consequential and Incidental Damages

IT IS SPECIFICALLY ACKNOWLEDGED THAT THIS WARRANTY, ANY OTHER EXPRESS WARRANTY NOT NEGATED HEREBY, AND ANY IMPLIED WARRANTY NOT NEGATED HEREBY, INCLUDING THE IMPLIED WARRANTIES OF MERCHANTABILITY AND FITNESS FOR A PARTICULAR PURPOSE, DO NOT COVER, AND NEITHER TLV, TII NOR ITS TLV GROUP COMPANIES WILL IN ANY EVENT BE LIABLE FOR, INCIDENTAL OR CONSEQUENTIAL DAMAGES, INCLUDING, BUT NOT LIMITED TO LOST PROFITS, THE COST OF DISASSEMBLY AND SHIPMENT OF THE DEFECTIVE PRODUCT, INJURY TO OTHER PROPERTY, DAMAGE TO BUYER'S OR THE FIRST END USER'S PRODUCT, DAMAGE TO BUYER'S OR THE FIRST END USER'S PROCESSES, LOSS OF USE, OR OTHER COMMERCIAL LOSSES. WHERE, DUE TO OPERATION OF LAW, CONSEQUENTIAL AND INCIDENTAL DAMAGES UNDER THIS WARRANTY, UNDER ANY OTHER EXPRESS WARRANTY NOT NEGATED HEREBY OR UNDER ANY IMPLIED WARRANTY NOT NEGATED HEREBY (INCLUDING THE IMPLIED WARRANTIES OF MERCHANTABILITY AND FITNESS FOR A PARTICULAR PURPOSE) CANNOT BE EXCLUDED, SUCH DAMAGES ARE EXPRESSLY LIMITED IN AMOUNT TO THE PURCHASE PRICE OF THE DEFECTIVE PRODUCT. THIS EXCLUSION OF CONSEQUENTIAL AND INCIDENTAL DAMAGES, AND THE PROVISION OF THIS WARRANTY LIMITING REMEDIES HEREUNDER TO REPLACEMENT, ARE INDEPENDENT PROVISIONS, AND ANY DETERMINATION THAT THE LIMITATION OF REMEDIES FAILS OF ITS ESSENTIAL PURPOSE OR ANY OTHER DETERMINATION THAT EITHER OF THE ABOVE REMEDIES IS UNENFORCEABLE, SHALL NOT BE CONSTRUED TO MAKE THE OTHER PROVISIONS UNENFORCEABLE.

Exclusion of Other Warranties

THIS WARRANTY IS IN LIEU OF ALL OTHER WARRANTIES, EXPRESS OR IMPLIED, AND ALL OTHER WARRANTIES, INCLUDING BUT NOT LIMITED TO THE IMPLIED WARRANTIES OF MERCHANTABILITY AND FITNESS FOR A PARTICULAR PURPOSE, ARE EXPRESSLY DISCLAIMED.

Severability

Any provision of this warranty which is invalid, prohibited or unenforceable in any jurisdiction shall, as to such jurisdiction, be ineffective to the extent of such invalidity, prohibition or unenforceability without invalidating the remaining provisions hereof, and any such invalidity, prohibition or unenforceability in any such jurisdiction shall not invalidate or render unenforceable such provision in any other jurisdiction.

Service

For Service or Technical Assistance: Contact your TLV representative or your regional TLV office.

In Europe:

TLV EURO ENGINEERING GmbH

Daimler-Benz-Straße 16-18, 74915 Waibstadt, **Germany**

Tel: [49]-(0)7263-9150-0

Fax: [49]-(0)7263-9150-50

TLV EURO ENGINEERING UK LTD.

Units 7 & 8, Furlong Business Park, Bishops Cleeve, Gloucestershire GL52 8TW, **U.K.**

Tel: [44]-(0)1242-227223

Fax: [44]-(0)1242-223077

TLV EURO ENGINEERING FRANCE SARL

Parc d'Ariane 2, bât. C, 290 rue Ferdinand Perrier, 69800 Saint Priest, **France**

Tel: [33]-(0)4-72482222

Fax: [33]-(0)4-72482220

In North America:

TLV CORPORATION

13901 South Lakes Drive, Charlotte, NC 28273-6790, **U.S.A.**

Tel: [1]-704-597-9070

Fax: [1]-704-583-1610

In Mexico and Latin America:

TLV ENGINEERING S. A. DE C. V.

Av. Jesús del Monte 39-B-1001, Col. Hda. de las Palmas, Huixquilucan, Edo. de México, 52763, **Mexico**

Tel: [52]-55-5359-7949

Fax: [52]-55-5359-7585

In Oceania:

TLV PTY LIMITED

Unit 8, 137-145 Rooks Road, Nunawading, Victoria 3131, **Australia**

Tel: [61]-(0)3-9873 5610

Fax: [61]-(0)3-9873 5010

In East Asia:

TLV PTE LTD

36 Kaki Bukit Place, #02-01/02, **Singapore** 416214

Tel: [65]-6747 4600

Fax: [65]-6742 0345

TLV SHANGHAI CO., LTD.

Room 5406, No. 103 Cao Bao Road, Shanghai, **China** 200233

Tel: [86]-(0)21-6482-8622

Fax: [86]-(0)21-6482-8623

TLV ENGINEERING SDN. BHD.

No.16, Jalan MJ14, Taman Industri Meranti Jaya, 47120 Puchong, Selangor, **Malaysia**

Tel: [60]-3-8065-2928

Fax: [60]-3-8065-2923

TLV PRIVATE LIMITED

252/94 (K-L) 17th Floor, Muang Thai-Phatra Complex Tower B, Rachadaphisek Road, Huaykwang, Bangkok 10310, **Thailand**

Tel: [66]-2-693-3799

Fax: [66]-2-693-3979

TLV INC.

#302-1 Bundang Technopark B, 723 Pangyo-ro, Bundang, Seongnam, Gyeonggi, 13511, **Korea**

Tel: [82]-(0)31-726-2105

Fax: [82]-(0)31-726-2195

In the Middle East:

TLV ENGINEERING FZCO

Building 2W, No. M002, PO Box 371684, Dubai Airport Free Zone, Dubai, **UAE**

Email: sales-me@tlv.co.jp

In Other Countries:

TLV INTERNATIONAL, INC.

881 Nagasuna, Noguchi, Kakogawa, Hyogo 675-8511, **Japan**

Tel: [81]-(0)79-427-1818

Fax: [81]-(0)79-425-1167

Manufacturer:

TLV CO., LTD.

881 Nagasuna, Noguchi, Kakogawa, Hyogo 675-8511, **Japan**

Tel: [81]-(0)79-422-1122

Fax: [81]-(0)79-422-0112

Options

The options shown below are available for this product on request. Please compare with the product you received.

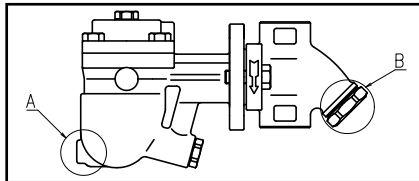

Options for Area A (standard: without drain plug)

With Drain Plug

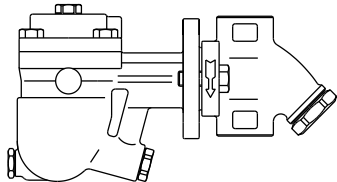

Part Name	Torque		Distance Across Flats	
	N-m	(lbf ft)	mm	(in)
Drain Plug	35	(26)	21	(13/16)

(1 N·m ≈ 10 kg·cm)

Options for Area B (screen holder)

With Blowdown Valve (TLV-BD2)



Always wear eye protection and heat-resistant gloves when operating the blowdown valve. Failure to do so may result in burns or other injury.



When operating the blowdown valve, stand to the side well clear of the outlet to avoid contact with internal fluids that will be discharged. Operate the valve slowly and surely, taking care to avoid the area from which internal fluids are discharged and any fluids deflected off piping or the ground etc. Failure to do so may result in burns or other injury.



Do not tighten the BD2 valve or the BD2 valve seat in excess of the appropriate tightening torque. Over-tightening may cause breakage to threaded portions, which may cause burns, other injuries or damage.



Do not excessively loosen the BD2 valve when opening the blowdown valve. The valve stopper pin installed to prevent the BD2 valve from being removed may break and internal pressure may result in the BD2 valve being blown off, leading to injuries, damage and fluid discharge, causing burns.

Configuration

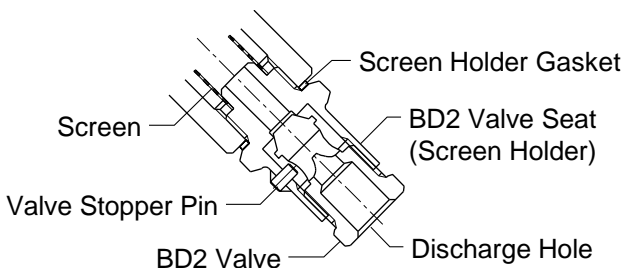
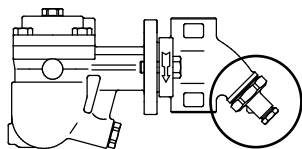

TLV Blowdown Valve: BD2

The BD2 Blowdown Valve, installed in the screen area of the connector body, uses the trap's internal pressure to blow any condensate, steam, dirt or scale accumulated around the screen area out to atmosphere.

BD2 Blowdown Valve Operation

1. The BD2 valve is in the closed position when the BD2 is shipped from the factory. Before attempting to operate the BD2, reconfirm that the BD2 valve is still in the closed position. Locate the blow outlet and, during operation, stand to the side and well clear of it, as the jet of condensate or steam could cause burns.
2. Remain in the area the entire time the BD2 valve is in the open position. Before opening the BD2 valve, grip the BD2 valve seat with a wrench and hold firmly in place so that it will not rotate when the BD2 valve is loosened. Grip the BD2 valve with another wrench and slowly loosen. Condensate and steam will discharge from the blow outlet in a jet stream. Be careful not to loosen the BD2 valve so far that it becomes removed from the BD2 valve seat. (If the valve stopper pin becomes damaged, large quantities of steam will be discharged in a jet stream.)
3. Close the BD2 valve until the flow of fluid completely stops. If the flow of fluid does not stop, re-open the BD2 valve (as in step “2”) to blow out any scale or dirt that may be caught in the BD2. Re-tighten the BD2 valve until the flow of fluid stops completely.

Tightening Torques and Distance Across Flats				
Part	Torque		Distance Across Flats	
	N·m	(lbf·ft)	mm	(in)
BD2 Valve	30	(22)	17	(²¹ / ₃₂)
BD2 Valve Seat (Screen Holder)	150	(110)	38	(1 ¹ / ₂)

NOTE: Avoid the use of excessive tightening torques, as threaded parts may become damaged. (1 N·m ≈ 10 kg·cm)