

ISO 9001
ISO 14001



Manufacturer

TLV CO., LTD.

Kakogawa, Japan

is approved by LRQA Ltd. to ISO 9001/14001



Instruction Manual

Free Float Steam Trap with X-element: JH8R-X

172-65463M-05

Publication date 5 August 2022

Copyright © 2022 TLV CO., LTD.

Table of Contents

- Introduction 3
- Safety Considerations 4
- Checking the Piping 6
- Operation 7
- Specifications 9
- Configuration 10
- Installation 12
- Maintenance 13
- Disassembly/Reassembly 15
- Instructions for Plug/Holder Disassembly and Reassembly 18
- Troubleshooting 19
- TLV EXPRESS LIMITED WARRANTY 20
- Service 22
- Options 23

Introduction

Thank you for purchasing the TLV free float steam trap.

This product has been thoroughly inspected before being shipped from the factory. When the product is delivered, before doing anything else, check the specifications and external appearance to make sure nothing is out of the ordinary. Also be sure to read this manual carefully before use and follow the instructions to be sure of using the product properly.

This free float steam trap employs a hinge-less and lever-less free float to rapidly, automatically and continuously discharge the inflowing condensate that is continuously generated inside the equipment, thus preventing the accumulation of condensate and thereby improving the heat transfer efficiency of the equipment. This steam trap is also of a revolutionary design featuring an integral air vent that employs a high-performance X-element. The X-element is very sensitive to changes in temperature, and responds with great accuracy. As a result, air and the large quantities of condensate created immediately after the start-up of operation are quickly discharged, thereby greatly reducing start-up time and also proving useful in valve operation (bypass blowdown) labor-saving.

The X-element is also sensitive to hot air during operation, responding quickly and thus preventing the occurrence of air binding. These features make this free float steam trap ideally suited for use on process systems and equipment (steam-using equipment), and it is especially well-suited for removing condensate from equipment used for batch operations, which often experience entrained air during operation.

If detailed instructions for special order specifications or options not contained in this manual are required, please contact TLV for full details.

This instruction manual is intended for use with the model(s) listed on the front cover. It is necessary not only for installation, but for subsequent maintenance, disassembly/reassembly and troubleshooting. Please keep it in a safe place for future reference.

Safety Considerations

- Read this section carefully before use and be sure to follow the instructions.
- Installation, inspection, maintenance, repairs, disassembly, adjustment and valve opening/closing should be carried out only by trained maintenance personnel.
- The precautions listed in this manual are designed to ensure safety and prevent equipment damage and personal injury. For situations that may occur as a result of erroneous handling, three different types of cautionary items are used to indicate the degree of urgency and the scale of potential damage and danger: DANGER, WARNING and CAUTION.
- The three types of cautionary items above are very important for safety: be sure to observe all of them as they relate to installation, use, maintenance and repair. Furthermore, TLV accepts no responsibility for any accidents or damage occurring as a result of failure to observe these precautions.

Cautionary items and definitions



Danger

Indicates an urgent situation which poses a threat of death or serious injury



Warning

Indicates that there is a potential threat of death or serious injury



Caution

Indicates that there is a possibility of injury or equipment/product damage

Safety Considerations for the Product



Warning

NEVER apply direct heat to the float. The float may explode due to increased internal pressure, causing accidents leading to serious injury or damage to property and equipment.



Caution

Install properly and DO NOT use this product outside the recommended operating pressure, temperature and other specification ranges. Improper use may result in such hazards as damage to the product or malfunctions that may lead to serious accidents. Local regulations may restrict the use of this product to below the conditions quoted.



Caution

DO NOT use this product in excess of the maximum operating pressure differential. Such use could make discharge impossible (blocked).



Caution

Use hoisting equipment for heavy objects (weighing approximately 20 kg (44 lb) or more). Failure to do so may result in back strain or other injury if the object should fall.



Caution

Use the eye bolts for removing the cover only; DO NOT use the eye bolts for hoisting the product. Eye bolts may break under strain, possibly resulting in serious injury.



Caution

Take measures to prevent people from coming into direct contact with product outlets. Failure to do so may result in burns or other injury from the discharge of fluids.



Caution

When disassembling or removing the product, wait until the internal pressure equals atmospheric pressure and the surface of the product has cooled to room temperature. Disassembling or removing the product when it is hot or under pressure may lead to discharge of fluids, causing burns, other injuries or damage.



Caution

Be sure to use only the recommended components when repairing the product, and NEVER attempt to modify the product in any way. Failure to observe these precautions may result in damage to the product and burns or other injury due to malfunction or the discharge of fluids.



Caution

Use only under conditions in which no freeze-up will occur. Freezing may damage the product, leading to fluid discharge, which may cause burns or other injury.



Caution

Use only under conditions in which no water hammer will occur. The impact of water hammer may damage the product, leading to fluid discharge, which may cause burns or other injury.

Checking the Piping



Caution

Use only under conditions in which no water hammer will occur. The impact of water hammer may damage the product, leading to fluid discharge, which may cause burns or other injury.

Check to make sure that the pipes to be connected to the product have been installed properly.

1. Is the pipe diameter suitable?
2. Is the piping where the product is to be installed horizontal?
3. Is the piping where the product is to be installed horizontal?
4. Has sufficient space been secured for maintenance?
5. Have isolation valves been installed at the inlet and outlet? If the outlet is subject to back pressure, has a check valve (TLV-CK) been installed?
6. Is the inlet pipe as short as possible, with as few bends as possible, and installed so the liquid will flow naturally down into the product?
7. Has the piping work been done correctly, as shown in the figures below?

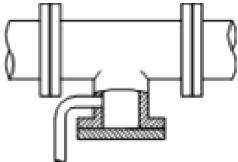
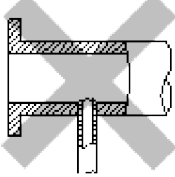
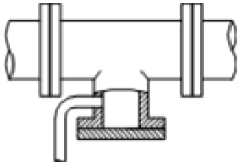
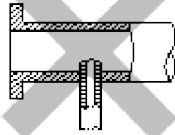
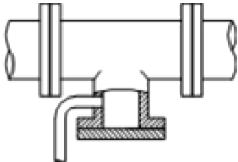
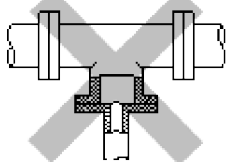
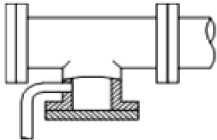
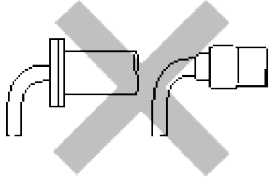
Requirement	Correct	Incorrect
Install catchpot with the proper diameter.		 Diameter is too small.
Make sure the flow of condensate is not obstructed.		 Diameter is too small and inlet protrudes into pipe interior.
To prevent rust and scale from flowing into the product, the inlet pipe should be connected 25 to 50 mm (1 to 2 in) above the base of the T-pipe.		 Rust and scale flow into the trap with the condensate.
When installing on the blind end, make sure the flow of condensate is not obstructed.		 Condensate collects in the pipe.

Operation

Principles of air and condensate discharge:

1. Start-up air and cold condensate discharge

At start-up, before steam is supplied, the trap is cold so the X-element is contracted and the air vent valve (A) is open. This allows for the rapid discharge of air through the air vent valve (A) and cold condensate through the orifice (B), when steam is first supplied to the system.

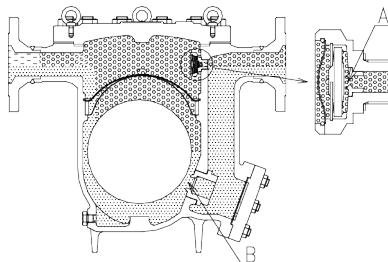

2. Condensate discharge

After the discharge of initial air and cold condensate, the heat of the inflowing steam and condensate causes the X-element to expand, closing the air vent valve (A). The rising condensate level causes the float to rise due to buoyancy, opening the orifice (B) and allowing condensate to be discharged.

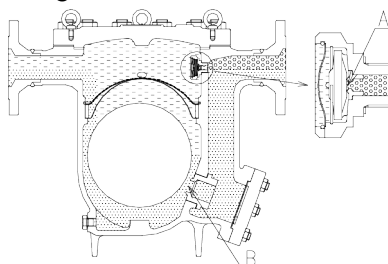

3. Hot air discharge

Should hot air flow into the trap with the steam during normal operation, the temperature of the X-element drops, causing it to momentarily contract and open the air vent valve (A), which allows for the rapid discharge of the air. After the air is discharged and steam contacts the X-element, the temperature will increase causing the air vent valve (A) to close.

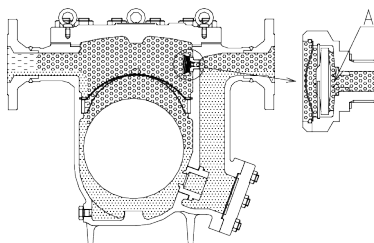

4. Discharge of large quantities of condensate

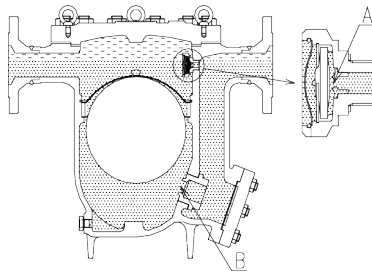

Increases in the condensate inflow rate cause the condensate level in the trap to rise. The float consequently rises and enlarges the opening of the orifice (B), allowing more condensate to be discharged. If condensate flows in at a faster rate than it discharges through the orifice (B), the temperature of the X-element drops, causing it to momentarily contract and open the air vent valve (A), which allows for the rapid discharge of the condensate through both (A) and (B). In this manner, continuous condensate discharge occurs while the opening size of the orifice varies depending on the condensate flow rate.

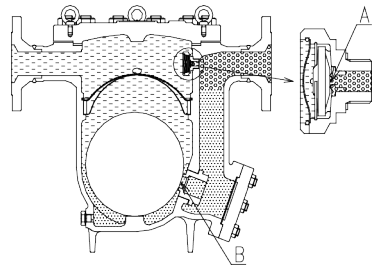

5. Closed position

When the condensate flow rate decreases, the X-element expands due to the heat of the steam, closing the air vent valve (A). In addition, the float falls as condensate is discharged, closing off the orifice (B). A water seal is maintained at all times over the orifice (B) to prevent steam loss.



-  Air
-  Steam
-  Condensate

Specifications



Caution

Install properly and DO NOT use this product outside the recommended operating pressure, temperature and other specification ranges. Improper use may result in such hazards as damage to the product or malfunctions that may lead to serious accidents. Local regulations may restrict the use of this product to below the conditions quoted.

DO NOT use this product in excess of the maximum operating pressure differential. Such use could make discharge impossible (blocked).

Use only under conditions in which no freeze-up will occur. Freezing may damage the unit, leading to fluid discharge, which may different cause burns or other injury.

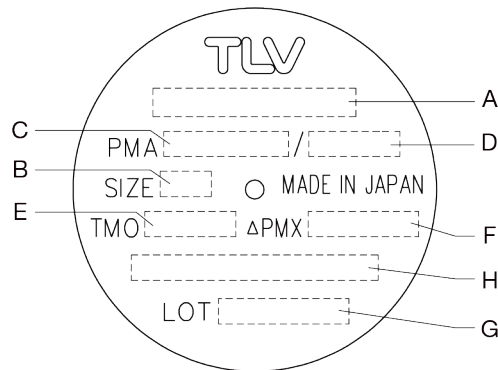

A	Model
B	Nominal Diameter
C	Maximum Allowable Pressure (PMA) ⁰¹
D	Maximum Allowable Temperature (TMA) ⁰¹
E	Maximum Operating Temperature (TMO)
F	Maximum Differential Pressure (PMX)
G	Production Lot No.
H	Valve No. ⁰²

⁰¹Maximum allowable pressure (PMA) and maximum allowable temperature (TMA) are PRESSURE SHELL DESIGN CONDITIONS, **NOT** OPERATING CONDITIONS.

⁰²Valve No. is displayed for products with options. This item is omitted from the nameplate when there are no options.

Configuration

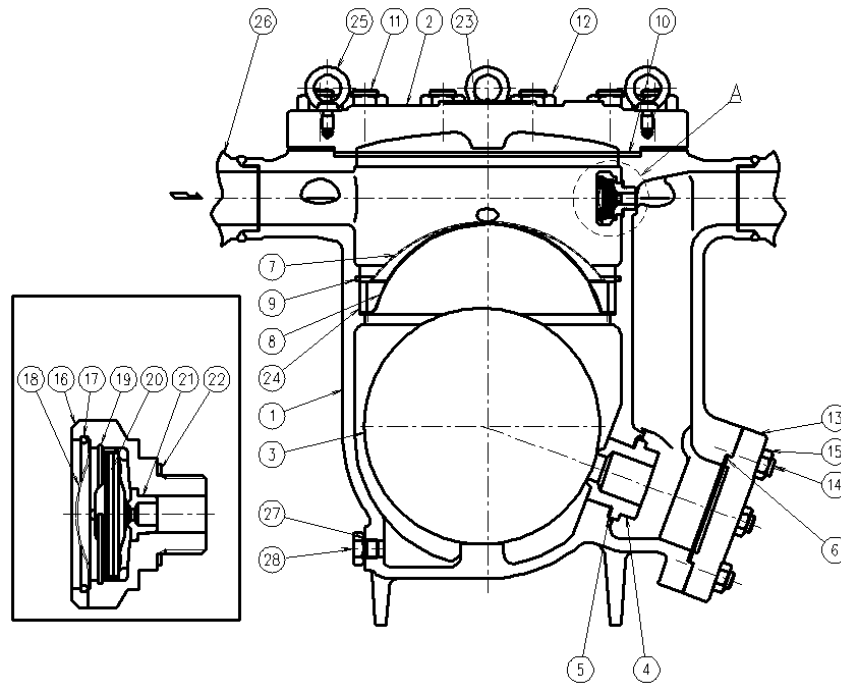

No	Part Name	Maintenance Kit	Repair Kit	X-element Kit	Float
1	Body				
2	Cover				
3	Float				✓
4	Orifice		✓		
5	Orifice Gasket	✓	✓		
6	Outlet Cover Gasket	✓	✓		
7	Screen		✓		
8	Screen Holder				
9	Snap Ring				
10	Cover Gasket	✓	✓		
11	Cover Bolt				
12	Cover Nut				
13	Outlet Cover				
14	Outlet Cover Bolt				
15	Outlet Cover Nut				
16	X-element Case			✓	
17	Snap Ring			✓	
18	X-element Screen			✓	
19	Spring Clip			✓	
20	X-element			✓	
21	Air Vent Valve Seat			✓	
22	X-element Case Gasket	✓	✓	✓	
23	Nameplate				
24	Screen Holder Retainer				
25	Eye Bolt				

No	Part Name	Maintenance Kit	Repair Kit	X-element Kit	Float
26	Flange/Socket				
27	Drain Plug Gasket	✓	✓		
28	Drain Plug				

Installation



Caution

Install properly and DO NOT use this product outside the recommended operating pressure, temperature and other specification ranges. Improper use may result in such hazards as damage to the product or malfunctions that may lead to serious accidents. Local regulations may restrict the use of this product to below the conditions quoted.

Use hoisting equipment for heavy objects (weighing approximately 20 kg (44 lb) or more). Failure to do so may result in back strain or other injury if the object should fall.

Use the eye bolts for removing the cover only; DO NOT use the eye bolts for hoisting the product. Eye bolts may break under strain, possibly resulting in serious injury.

Take measures to prevent people from coming into direct contact with product outlets. Failure to do so may result in burns or other injury from the discharge of fluids.

Installation, inspection, maintenance, repairs, disassembly and adjustment and valve opening/closing should be carried out only by trained maintenance personnel.

1. Before installation, be sure to remove all protective seals.
2. Before installing the product, blow out the inlet piping to remove any piping scraps, dirt and oil. Close the inlet valve after blowdown.
3. When hoisting the product, hang a wire around the inlet/outlet as close to the body as possible.
4. Install the product so the arrow on the body is pointing in the direction of flow.
5. The product should be inclined no more than 5° horizontally and front-to-back.
6. Install a condensate outlet valve and outlet piping.
7. Open the inlet and outlet valves and ensure that the product functions properly.

If there is a problem, determine the cause using the "Troubleshooting" section in this manual.

Tolerance Angle for Installation: 5°

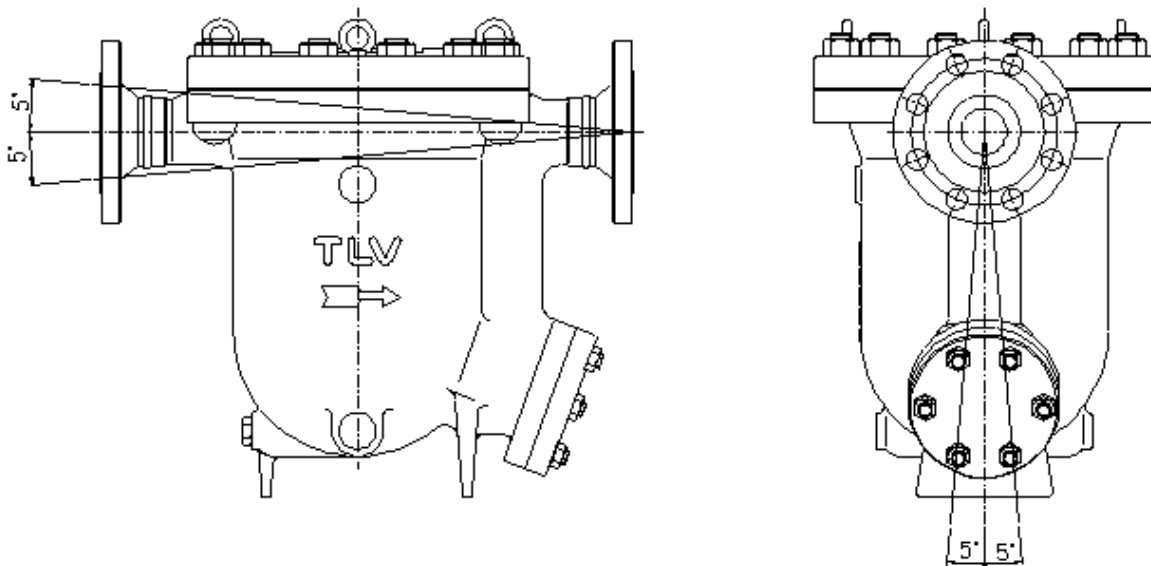

Make sure the product is installed with the raised TLV lettering on the body horizontal.

Maintenance



Caution

Take measures to prevent people from coming into direct contact with product outlets. Failure to do so may result in burns or other injury from the discharge of fluids.

Be sure to use only the recommended components when repairing the product, and NEVER attempt to modify the product in any way. Failure to observe these precautions may result in damage to the product and burns or other injury due to malfunction or the discharge of fluids.

Operational Check

A visual inspection of the following items should be done on a daily basis to determine whether the product is operating properly or has failed. Periodically (at least biannually) the operation should also be checked by using diagnostic equipment such as a stethoscope, thermometer, TLV Pocket TrapMan or TLV TrapMan.

If the product should fail, it may cause damage to piping and equipment, resulting in faulty or low quality products or losses due to steam leakage.

Normal:	Condensate is discharged continuously, together with flash steam, and the sound of flow can be heard. If there is very little condensate, there is almost no sound of flow.
Blocked (Discharge Impossible):	No condensate is discharged. The product is quiet and makes no noise, and the surface temperature of the product is low.
Blowing:	Live steam continually flows from the outlet and there is a continuous metallic sound.
Steam Leakage:	Live steam is discharged through the trap outlet together with condensate, accompanied by a high-pitched sound.

(When conducting a visual inspection, flash steam is sometimes mistaken for steam leakage. For this reason, the use of a steam trap diagnostic instrument such as TLV TrapMan in conjunction with the visual inspection is highly recommended.)

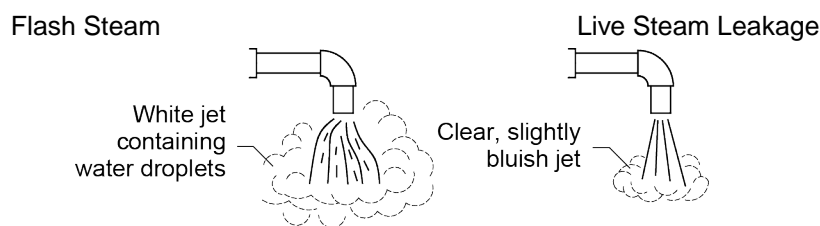

Parts Inspection

When parts have been removed, or during periodic inspections, use the following table to inspect the parts and replace any that are found to be defective.

Procedure

Gaskets: Check for warping or scratches

Screen: Check for clogging or corrosion

X-element: Check for scratches

Valve Seat: Check for scratches

Float: Check for scratches or dents

Orifice Opening: Check for dirt, oil film, wear or scratches

Disassembly/Reassembly



Warning

NEVER apply direct heat to the float. The float may explode due to increased internal pressure, causing accidents leading to serious injury or damage to property and equipment.



Caution

Use hoisting equipment for heavy objects (weighing approximately 20 kg (44 lb) or more). Failure to do so may result in back strain or other injury if the object should fall.

Use the eye bolts for removing the cover only; DO NOT use the eye bolts for hoisting the product. Eye bolts may break under strain, possibly resulting in serious injury.

When disassembling or removing the product, wait until the internal pressure equals atmospheric pressure and the surface of the product has cooled to room temperature. Disassembling or removing the product when it is hot or under pressure may lead to discharge of fluids, causing burns, other injuries or damage.

Use the following procedures to remove components. Use the same procedures in reverse to reassemble. (Installation, inspection, maintenance, repairs, disassembly, adjustment and valve opening/closing should be carried out only by trained maintenance personnel.)

Drain Plug

Part Name	During Disassembly	During Reassembly
Drain Plug 28	Remove with a socket wrench	Consult the table of tightening torques and tighten to the proper torque
Drain Plug Gasket 27	Remove the gasket and clean sealing surfaces	Replace with a new gasket; coat surfaces with anti-seize

Detaching/Reattaching the Cover

Part Name	During Disassembly	During Reassembly
Cover Nut 12	Remove with a socket wrench	Consult the table of tightening torques and tighten to the proper torque
Cover 2	Use all four (4) eye bolts to lift up and off, making sure to evenly distribute the weight of the cover among them	Make sure there are no pieces of the old gasket left on the sealing surfaces of the body and cover, align the arrows on the body and cover and reattach
Cover Gasket 10	Remove the gasket and clean sealing surfaces	Replace with a new gasket

Disassembly/Reassembly of the X-element Case and Components Inside the X-element Case

Part Name	During Disassembly	During Reassembly
X-element Case 16	Remove with a box wrench	Consult the table of tightening torques and tighten to the proper torque
X-element Case Gasket 22	Remove the gasket and clean sealing surfaces	Replace with a new gasket; coat surfaces with anti-seize
Snap Ring 17 (X-element Case 16)	Pinch the insides together and remove from the X-element case	Insert securely into the guide in the X-element case

Part Name	During Disassembly	During Reassembly
X-element Screen 18	Remove from the X-element case	Insert after making sure of the correct orientation
Spring Clip 19 (X-element 20)	Pinch the insides together and remove from the X-element case	Insert securely into the guide in the X-element case
X-element 20	Remove from the X-element case	Insert after making sure of the correct orientation



Note

Do not attempt to remove the press-in air vent valve seat from the X-element case.

Disassembly/Reassembly of Components Inside the Body



Note

The X-element case must be removed before the float can be removed.

Part Name	During Disassembly	During Reassembly
Snap Ring 9	Pinch insides together and remove from the body	Insert securely into the groove in the body
Screen 7	Remove by grasping the wire ring and lifting straight up and out	Set the screen on the screen holder and screen holder retainer and insert as far as the snap ring groove
Screen Holder Retainer 24	Remove without bending	Place on the screen holder without tilting
Screen Holder 8	Remove without bending	Place on the ledge inside the body, making sure the rounded side is on to
Float 3	Remove, being careful not to scratch the polished surface	Insert, being careful not to scratch the polished surface
Outlet Cover Nut 15	Remove with a socket wrench	Consult the table of tightening torques and tighten to the proper torque
Outlet Cover 13	Remove, being careful not to scratch the gasket sealing surfaces	Make sure there are no pieces of the old gasket left on the sealing surfaces of the body and cover
Outlet Cover Gasket 6	Remove the gasket and clean sealing surfaces	Replace with a new gasket
Orifice 4	Remove with a socket wrench	Consult the table of tightening torques and tighten to the proper torque
Orifice Gasket 5	Remove the gasket and clean sealing surfaces	Replace with a new gasket: coat surfaces with anti-seize

Table of Tightening Torques

Part Names	Torque (N·m)	Distance Across Flats (mm)
Orifice 4	1000	60
Outlet Cover Nut 15	160	24
Cover Nut 12	450	36
X-element Case 16	150	50
Drain Plug 28	100	26

**Note**

- Coat all threaded portions and valve seat gasket with anti-seize.
- If drawings or other special documentation were supplied for the product, any torque given there takes precedence over values shown here.

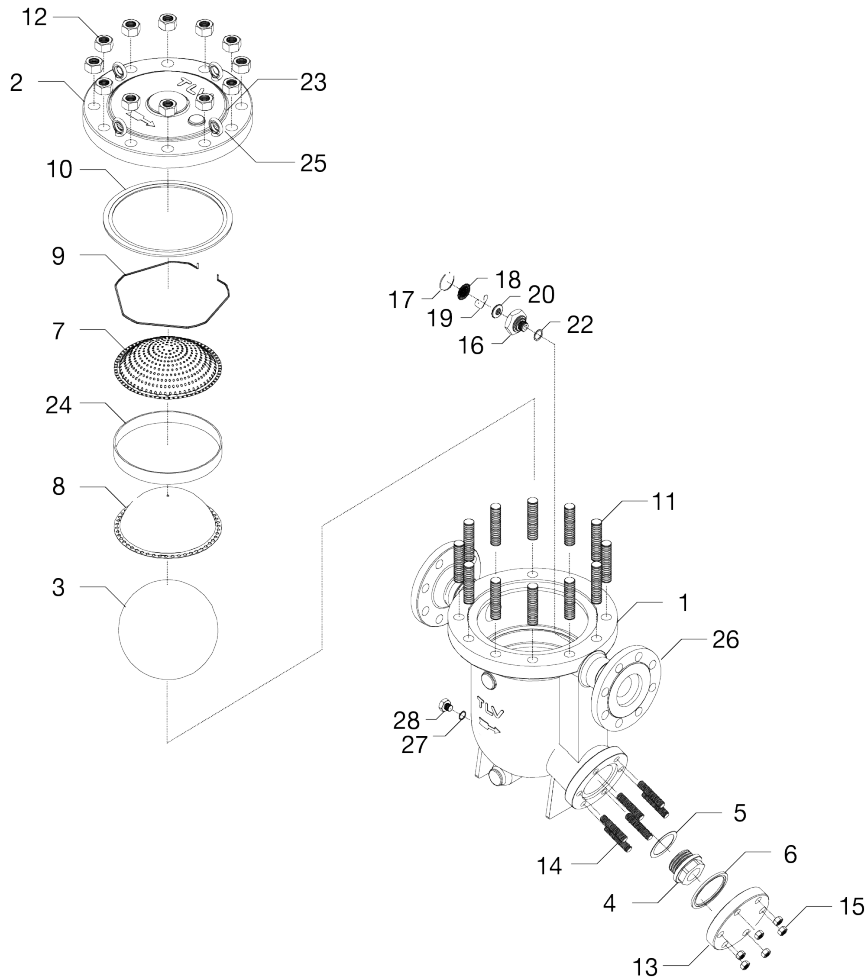
Exploded View

No.	Part Name	No.	Part Name
1	Body	15	Outlet Cover Nut
2	Cover	16	X-element Case
3	Float	17	Snap Ring
4	Orifice	18	X-element Screen
5	Orifice Gasket	19	Spring Clip
6	Outlet Cover Gasket	20	X-element
7	Screen	21	Air Vent Valve Seat
8	Screen Holder	22	X-element Case Gasket
9	Snap Ring	23	Nameplate
10	Cover Gasket	24	Screen Holder Retainer
11	Cover Bolt	25	Eye Bolt
12	Cover Nut	26	Flange (Socket)
13	Outlet Cover	27	Drain Plug Gasket
14	Outlet Cover Bolt	28	Drain Plug

Instructions for Plug/Holder Disassembly and Reassembly

The seal on the threaded plugs/holders found on TLV products is formed by a flat metal gasket. There are various installation orientations for the gaskets, such as horizontal, diagonal and downward, and the gasket may be pinched in the thread recesses during assembly.

Instructions for Disassembly and Reassembly

1. Remove the plug/holder using a tool of the specified size (distance across flats).
2. The gasket should not be reused. Be sure to replace it with a new gasket.
3. Clean the gasket surfaces of the plug/holder and the product body using a rag and/or cleaning agents, then check to make sure the surfaces are not scratched or deformed.

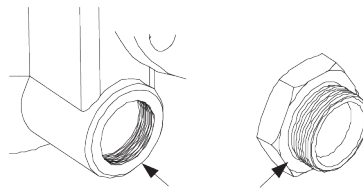

4. Coat both the gasket surface of the plug/holder and the threads of the plug/holder with anti-seize, then press the gasket onto the center of the gasket surface of the plug/holder, making sure the anti-seize affixes the gasket tightly to the plug/holder. Check to make sure the gasket is not caught in the recesses of the threads.

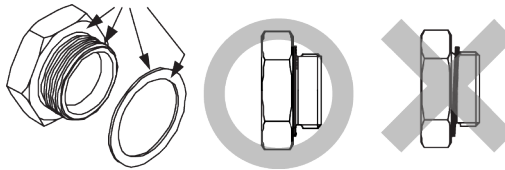

5. Hold the plug/holder upside down to make sure that the anti-seize makes the gasket stick to the plug/holder even when the plug/holder is held upside down.

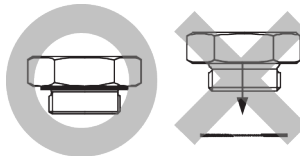

6. Screw the plug/holder by hand into the product body while making sure that the gasket remains tightly affixed to the center of the gasket surface of the plug/holder. Make sure the entire gasket is making contact with the gasket surface of the product body. It is important at this point to make sure the gasket is not pinched in the thread recesses of the plug/holder.

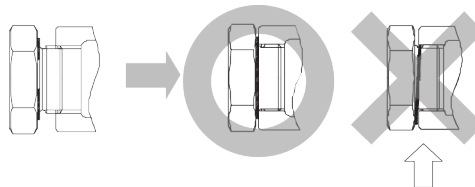

7. Tighten the plug/holder to the proper torque.
8. Next, begin the supply of steam and check to make sure there is no leakage from the part just tightened. If there is leakage, immediately close the inlet valve and, if there is a bypass valve, take the necessary steps to release any residual pressure. After the surface of the product cools to room temperature, repeat the procedure beginning from step 1.

Troubleshooting



Warning

NEVER apply direct heat to the float. The float may explode due to increased internal pressure, causing accidents leading to serious injury or damage to property and equipment.



Caution

When disassembling or removing the product, wait until the internal pressure equals atmospheric pressure and the surface of the product has cooled to room temperature. Disassembling or removing the product when it is hot or under pressure may lead to discharge of fluids, causing burns, other injuries or damage.

If the product fails to operate properly, use the following table to locate the cause and remedy.

Problem	Cause	Remedy
No condensate is discharged (blocked) or discharge is poor	The float is damaged or filled with condensate	Replace with a new float
	The orifice opening, screen or piping are clogged with rust and scale	Clean parts
	The X-element is scratched or damaged	Replace with a new X-element
	Steam-locking has occurred	Perform a bypass blowdown or close the product inlet valve and allow the product to cool
	The product operating pressure exceeds the maximum specified pressure, or whether there is insufficient pressure differential between the product inlet and outlet	Compare specifications and actual operating conditions
Steam is discharged or leaks from the outlet (blowing) (steam leakage)	Build-up on the seating surface of the orifice or rust and scale build-up beneath the float	Clean parts
	Scratches on the orifice	Replace with a new orifice
	The float is misshapen or has a build-up	Clean or replace with a new float
	Improper installation orientation	Correct the installation
	Product vibration	Lengthen the inlet piping and fasten it securely
	The air vent valve seating area of the X-element and/or air vent valve seat have a build-up or are scratched	Clean the air vent valve seating area of the X-element and/or air vent valve seat or replace the X-element unit
Steam is leaking from a place other than the outlet	Gasket deterioration or damage	Replace with new gasket(s)
	Improper tightening torques were used	Tighten to the proper torque
Float frequently becomes damaged	Water hammer has occurred	Study and correct the piping



Note

When replacing parts with new, use the parts list for reference, and replace with parts from the Maintenance Kit, Repair Kit, etc. Please note that replacement parts are only available as part of a replacement parts kit.

TLV EXPRESS LIMITED WARRANTY

Subject to the limitations set forth below, TLV CO., LTD., a Japanese corporation (“**TLV**”), warrants that products which are sold by it, TLV International Inc. (“**TII**”) or one of its group companies excluding TLV Corporation (a corporation of the United States of America), (hereinafter the “**Products**”) are designed and manufactured by TLV, conform to the specifications published by TLV for the corresponding part numbers (the “**Specifications**”) and are free from defective workmanship and materials. The party from whom the Products were purchased shall be known hereinafter as the “**Seller**”. With regard to products or components manufactured by unrelated third parties (the “**Components**”), TLV provides no warranty other than the warranty from the third party manufacturer(s), if any.

Exceptions to Warranty

This warranty does not cover defects or failures caused by:

1. improper shipping, installation, use, handling, etc., by persons other than TLV, TII or TLV group company personnel, or service representatives authorized by TLV; or
2. dirt, scale or rust, etc.; or
3. improper disassembly and reassembly, or inadequate inspection and maintenance by persons other than TLV or TLV group company personnel, or service representatives authorized by TLV; or
4. disasters or forces of nature or Acts of God; or
5. abuse, abnormal use, accidents or any other cause beyond the control of TLV, TII or TLV group companies; or
6. improper storage, maintenance or repair; or
7. operation of the Products not in accordance with instructions issued with the Products or with accepted industry practices; or
8. use for a purpose or in a manner for which the Products were not intended; or
9. use of the Products in a manner inconsistent with the Specifications; or
10. use of the Products with Hazardous Fluids (fluids other than steam, air, water, nitrogen, carbon dioxide and inert gases (helium, neon, argon, krypton, xenon and radon)); or
11. failure to follow the instructions contained in the TLV Instruction Manual for the Product.

Duration of Warranty

This warranty is effective for a period of one (1) year after delivery of Products to the first end user. Notwithstanding the foregoing, asserting a claim under this warranty must be brought within three (3) years after the date of delivery to the initial buyer if not sold initially to the first end user.

ANY IMPLIED WARRANTIES NOT NEGATED HEREBY WHICH MAY ARISE BY OPERATION OF LAW, INCLUDING THE IMPLIED WARRANTIES OF MERCHANTABILITY AND FITNESS FOR A PARTICULAR PURPOSE AND ANY EXPRESS WARRANTIES NOT NEGATED HEREBY, ARE GIVEN SOLELY TO THE INITIAL BUYER AND ARE LIMITED IN DURATION TO ONE (1) YEAR FROM THE DATE OF SHIPMENT BY THE SELLER.

Exclusive Remedy

THE EXCLUSIVE REMEDY UNDER THIS WARRANTY, UNDER ANY EXPRESS WARRANTY OR UNDER ANY IMPLIED WARRANTIES NOT NEGATED HEREBY (INCLUDING THE IMPLIED WARRANTIES OF MERCHANTABILITY AND FITNESS FOR A PARTICULAR PURPOSE), IS **REPLACEMENT**; PROVIDED: (a) THE CLAIMED DEFECT IS

REPORTED TO THE SELLER IN WRITING WITHIN THE WARRANTY PERIOD, INCLUDING A DETAILED WRITTEN DESCRIPTION OF THE CLAIMED DEFECT AND HOW AND WHEN THE CLAIMED DEFECTIVE PRODUCT WAS USED; AND (b) THE CLAIMED DEFECTIVE PRODUCT AND A COPY OF THE PURCHASE INVOICE IS RETURNED TO THE SELLER, FREIGHT AND TRANSPORTATION COSTS PREPAID, UNDER A RETURN MATERIAL AUTHORIZATION AND TRACKING NUMBER ISSUED BY THE SELLER. ALL LABOR COSTS, SHIPPING COSTS, AND TRANSPORTATION COSTS ASSOCIATED WITH THE RETURN OR REPLACEMENT OF THE CLAIMED DEFECTIVE PRODUCT ARE SOLELY THE RESPONSIBILITY OF BUYER OR THE FIRST END USER. THE SELLER RESERVES THE RIGHT TO INSPECT ON THE FIRST END USER'S SITE ANY PRODUCTS CLAIMED TO BE DEFECTIVE BEFORE ISSUING A RETURN MATERIAL AUTHORIZATION. SHOULD SUCH INSPECTION REVEAL, IN THE SELLER'S REASONABLE DISCRETION, THAT THE CLAIMED DEFECT IS NOT COVERED BY THIS WARRANTY, THE PARTY ASSERTING THIS WARRANTY SHALL PAY THE SELLER FOR THE TIME AND EXPENSES RELATED TO SUCH ON-SITE INSPECTION.

Exclusion of Consequential and Incidental Damages

IT IS SPECIFICALLY ACKNOWLEDGED THAT THIS WARRANTY, ANY OTHER EXPRESS WARRANTY NOT NEGATED HEREBY, AND ANY IMPLIED WARRANTY NOT NEGATED HEREBY, INCLUDING THE IMPLIED WARRANTIES OF MERCHANTABILITY AND FITNESS FOR A PARTICULAR PURPOSE, DO NOT COVER, AND NEITHER TLV, TII NOR ITS TLV GROUP COMPANIES WILL IN ANY EVENT BE LIABLE FOR, INCIDENTAL OR CONSEQUENTIAL DAMAGES, INCLUDING, BUT NOT LIMITED TO LOST PROFITS, THE COST OF DISASSEMBLY AND SHIPMENT OF THE DEFECTIVE PRODUCT, INJURY TO OTHER PROPERTY, DAMAGE TO BUYER'S OR THE FIRST END USER'S PRODUCT, DAMAGE TO BUYER'S OR THE FIRST END USER'S PROCESSES, LOSS OF USE, OR OTHER COMMERCIAL LOSSES. WHERE, DUE TO OPERATION OF LAW, CONSEQUENTIAL AND INCIDENTAL DAMAGES UNDER THIS WARRANTY, UNDER ANY OTHER EXPRESS WARRANTY NOT NEGATED HEREBY OR UNDER ANY IMPLIED WARRANTY NOT NEGATED HEREBY (INCLUDING THE IMPLIED WARRANTIES OF MERCHANTABILITY AND FITNESS FOR A PARTICULAR PURPOSE) CANNOT BE EXCLUDED, SUCH DAMAGES ARE EXPRESSLY LIMITED IN AMOUNT TO THE PURCHASE PRICE OF THE DEFECTIVE PRODUCT. THIS EXCLUSION OF CONSEQUENTIAL AND INCIDENTAL DAMAGES, AND THE PROVISION OF THIS WARRANTY LIMITING REMEDIES HEREUNDER TO REPLACEMENT, ARE INDEPENDENT PROVISIONS, AND ANY DETERMINATION THAT THE LIMITATION OF REMEDIES FAILS OF ITS ESSENTIAL PURPOSE OR ANY OTHER DETERMINATION THAT EITHER OF THE ABOVE REMEDIES IS UNENFORCEABLE, SHALL NOT BE CONSTRUED TO MAKE THE OTHER PROVISIONS UNENFORCEABLE.

Exclusion of Other Warranties

THIS WARRANTY IS IN LIEU OF ALL OTHER WARRANTIES, EXPRESS OR IMPLIED, AND ALL OTHER WARRANTIES, INCLUDING BUT NOT LIMITED TO THE IMPLIED WARRANTIES OF MERCHANTABILITY AND FITNESS FOR A PARTICULAR PURPOSE, ARE EXPRESSLY DISCLAIMED.

Severability

Any provision of this warranty which is invalid, prohibited or unenforceable in any jurisdiction shall, as to such jurisdiction, be ineffective to the extent of such invalidity, prohibition or unenforceability without invalidating the remaining provisions hereof, and any such invalidity, prohibition or unenforceability in any such jurisdiction shall not invalidate or render unenforceable such provision in any other jurisdiction.

Service

For Service or Technical Assistance: Contact your TLV representative or your regional TLV office.

In Europe:

TLV EURO ENGINEERING GmbH

Daimler-Benz-Straße 16-18, 74915 Waibstadt, **Germany**

Tel: [49]-(0)7263-9150-0

Fax: [49]-(0)7263-9150-50

TLV EURO ENGINEERING UK LTD.

Units 7 & 8, Furlong Business Park, Bishops Cleeve,
Gloucestershire GL52 8TW, **U.K.**

Tel: [44]-(0)1242-227223

Fax: [44]-(0)1242-223077

TLV EURO ENGINEERING FRANCE SARL

Parc d'Ariane 2, bât. C, 290 rue Ferdinand Perrier, 69800 Saint
Priest, **France**

Tel: [33]-(0)4-72482222

Fax: [33]-(0)4-72482220

In North America:

TLV CORPORATION

13901 South Lakes Drive, Charlotte, NC 28273-6790, **U.S.A.**

Tel: [1]-704-597-9070

Fax: [1]-704-583-1610

TLV ENGINEERING S. A. DE C.V.

Av. Jesús del Monte 39-B-1001, Col. Hda. de las Palmas,
Huixquilucan, Edo. de México, 52763, **Mexico**

Tel: [52]-55-5359-7949

Fax: [52]-55-5359-7585

In Oceania:

TLV PTY LIMITED

Unit 8, 137-145 Rooks Road, Nunawading, Victoria 3131,
Australia

Tel: [61]-(0)3-9873 5610

Fax: [61]-(0)3-9873 5010

In East Asia:

TLV PTE LTD

36 Kaki Bukit Place, #02-01/02, **Singapore** 416214

Tel: [65]-6747 4600

Fax: [65]-6742 0345

TLV SHANGHAI CO., LTD.

5/F, Building 7, No.103 Caobao Road, Xuhui District, Shanghai,
China 200233

Tel: [86]-(0)21-6482-8622

Fax: [86]-(0)21-6482-8623

TLV ENGINEERING SDN. BHD.

No.16, Jalan MJ14, Taman Industri Meranti Jaya, 47120 Puchong,
Selangor, **Malaysia**

Tel: [60]-3-8052-2928

Fax: [60]-3-8051-0899

TLV PRIVATE LIMITED

252/94 (K-L) 17th Floor, Muang Thai-Phatra Complex Tower B,
Rachadaphisek Road, Huaykwang, Bangkok 10310, **Thailand**

Tel: [66]-2-693-3799

Fax: [66]-2-693-3979

TLV INC.

#302-1 Bundang Technopark B, 723 Pangyo-ro, Bundang,
Seongnam, Gyeonggi, 13511, **Korea**

Tel: [82]-(0)31-726-2105

Fax: [82]-(0)31-726-2195

In the Middle East:

TLV ENGINEERING FZCO

Building 2W, No. M002, PO Box 371684, Dubai Airport Free Zone,
Dubai, **UAE**

Email: sales-me@tlv.co.jp

In Other Countries:

TLV INTERNATIONAL, INC.

881 Nagasuna, Noguchi, Kakogawa, Hyogo 675-8511, **Japan**

Tel: [81]-(0)79-427-1818

Fax: [81]-(0)79-425-1167

Manufacturer:

TLV CO., LTD.

881 Nagasuna, Noguchi, Kakogawa, Hyogo 675-8511, **Japan**

Tel: [81]-(0)79-427-1800

Fax: [81]-(0)79-422-2277

Options

The options shown below are available for this product on request. Please compare with the product you received.

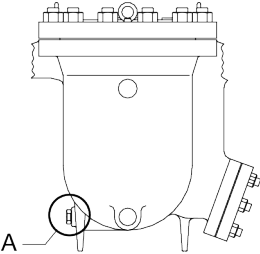

Options for Area A (standard: with drain plug)

Without Drain Plug

