

ISO 9001  
ISO14001



Manufacturer

**TLV** CO., LTD.

Kakogawa, Japan

is approved by LRQA Ltd. to ISO 9001:2001



# Instruction Manual

---

**Free Float Steam Trap: SS1-M2 Series**

Featured Models: SS1NL-M2/SS1NH-M2/SS1VL-M2/SS1VH-M2

172-65869-M-00

Publication date 3 March 2026

Copyright © 2026 TLV CO., LTD.

# Table of Contents

- Introduction ..... 3
- Safety Considerations ..... 4
- Checking the Piping ..... 6
- Operation ..... 7
- Specifications ..... 8
- Configuration ..... 9
- Installation ..... 10
- Maintenance ..... 11
- Disassembly/Reassembly ..... 12
- Troubleshooting ..... 15
- TLV EXPRESS LIMITED WARRANTY ..... 16
- Service ..... 18

# Introduction

Thank you for purchasing the TLV free float steam trap.

This product has been thoroughly inspected before being shipped from the factory. When the product is delivered, before doing anything else, check the specifications and external appearance to make sure nothing is out of the ordinary. Also be sure to read this manual carefully before use and follow the instructions to be sure of using the product properly.

This free float steam trap uses a precision-ground float and three-point support for the valve body. With no hinges or levers, the trap automatically continuously discharges condensate, preventing it from collecting.

The three-point seating for the valve body supports the precision-ground float securely at three points and ensures a high degree of sealing when even only minute quantities of condensate are present.

This free float steam trap is ideal for places at which extremely small amounts of condensate are generated, such as superheated and saturated steam mains and branches, and trace lines.

If detailed instructions for special order specifications or options not contained in this manual are required, please contact TLV for full details.

This instruction manual is intended for use with the model(s) listed on the front cover. It is necessary not only for installation, but for subsequent maintenance, disassembly/reassembly and troubleshooting. Please keep it in a safe place for future reference.

# Safety Considerations

- Read this section carefully before use and be sure to follow the instructions.
- Installation, inspection, maintenance, repairs, disassembly, adjustment and valve opening/closing should be carried out only by trained maintenance personnel.
- The precautions listed in this manual are designed to ensure safety and prevent equipment damage and personal injury. For situations that may occur as a result of erroneous handling, three different types of cautionary items are used to indicate the degree of urgency and the scale of potential damage and danger: DANGER, WARNING and CAUTION.
- The three types of cautionary items above are very important for safety: be sure to observe all of them as they relate to installation, use, maintenance and repair. Furthermore, TLV accepts no responsibility for any accidents or damage occurring as a result of failure to observe these precautions.

## Cautionary items and definitions



### Danger

Indicates an urgent situation which poses a threat of death or serious injury



### Warning

Indicates that there is a potential threat of death or serious injury



### Caution

Indicates that there is a possibility of injury or equipment/product damage

## Safety Considerations for the Product



### Warning

**NEVER apply direct heat to the float.** The float may explode due to increased internal pressure, causing accidents leading to serious injury or damage to property and equipment.



### Caution

**Install properly and DO NOT use this product outside the recommended operating pressure, temperature and other specification ranges.** Improper use may result in such hazards as damage to the product or malfunctions that may lead to serious accidents. Local regulations may restrict the use of this product to below the conditions quoted.



### Caution

**DO NOT use this product in excess of the maximum operating pressure differential.** Such use could make discharge impossible (blocked).



### Caution

**Take measures to prevent people from coming into direct contact with product outlets.** Failure to do so may result in burns or other injury from the discharge of fluids.



### Caution

**When disassembling or removing the product, wait until the internal pressure equals atmospheric pressure and the surface of the product has cooled to room temperature.** Disassembling or removing the product when it is hot or under pressure may lead to discharge of fluids, causing burns, other injuries or damage.



**Caution**

**Be sure to use only the recommended components when repairing the product, and NEVER attempt to modify the product in any way.** Failure to observe these precautions may result in damage to the product and burns or other injury due to malfunction or the discharge of fluids.



**Caution**

**Do not use excessive force when connecting threaded pipes to the product.** Over-tightening may cause breakage leading to fluid discharge, which may cause burns or other injury.



**Caution**

**Use only under conditions in which no freeze-up will occur.** Freezing may damage the product, leading to fluid discharge, which may cause burns or other injury.



**Caution**

**Use only under conditions in which no water hammer will occur.** The impact of water hammer may damage the product, leading to fluid discharge, which may cause burns or other injury.

# Checking the Piping



## Caution

**Use only under conditions in which no water hammer will occur.** The impact of water hammer may damage the product, leading to fluid discharge, which may cause burns or other injury.

Check to make sure that the pipes to be connected to the product have been installed properly.

1. Is the pipe diameter suitable?
2. Is the piping where the product is to be installed horizontal (for the SS1NL-M2/SS1NH-M2) or vertical (for the SS1VL-M2/SS1VH-M2)?
3. Has sufficient space been secured for maintenance?
4. Have isolation valves been installed at the inlet and outlet?  
If the outlet is subject to back pressure, has a check valve (TLV-CK) been installed?
5. Is the inlet pipe as short as possible, with as few bends as possible, and installed so the liquid will flow naturally down into the product?
6. Has the piping work been done correctly, as shown in the figures below?

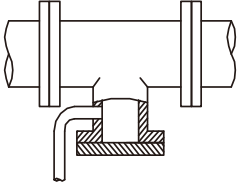
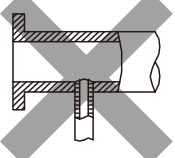
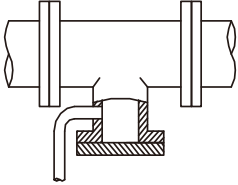
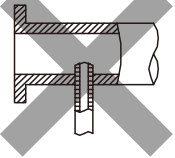
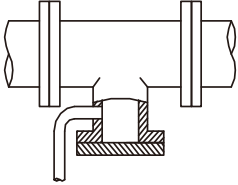
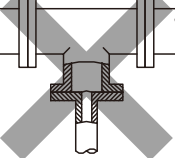
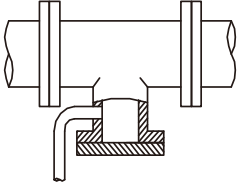
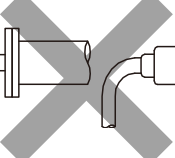
Requirement	Correct	Incorrect
Install catchpot with the proper diameter.		 Diameter is too small.
Make sure the flow of condensate is not obstructed.		 Diameter is too small and inlet protrudes into pipe interior.
To prevent rust and scale from flowing into the product, the inlet pipe should be connected 25 to 50 mm above the base of the T-pipe.		 Rust and scale flow into the trap with the condensate.
When installing on the blind end, make sure the flow of condensate is not obstructed.		 Condensate collects in the pipe.

# Operation

Principles of air and condensate discharge:

1. Start-up air and cold condensate discharge

At start-up, before steam is supplied, the system is cold and the bimetal air vent strip is contracted, holding the float off of the valve seat. This allows for the rapid discharge of air and cold condensate through the valve when steam is first supplied to the system.

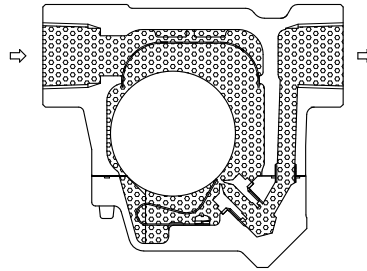

2. Condensate discharge

If the temperature of the condensate rises above 90 °C, the bimetal air vent strip expands allowing the float to block the valve seat. Rising condensate levels cause the float to rise due to buoyancy, opening the valve and allowing hot condensate to be discharged.

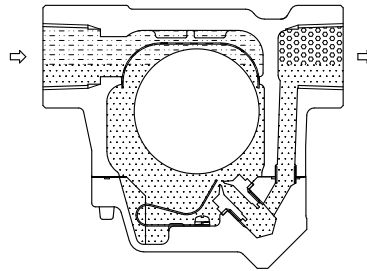

3. Closed position

When the condensate flow rate decreases, the float falls, closing off the valve seat opening. A water seal is maintained at all times over the valve seat opening to prevent steam loss.

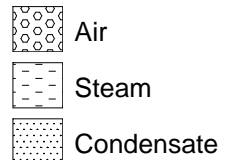
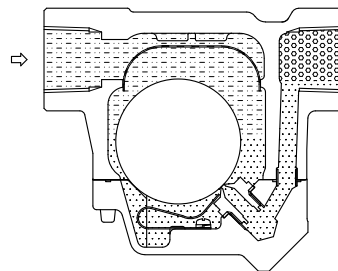

# Specifications



## Caution

**Install properly and DO NOT use this product outside the recommended operating pressure, temperature and other specification ranges.** Improper use may result in such hazards as damage to the product or malfunctions that may lead to serious accidents. Local regulations may restrict the use of this product to below the conditions quoted.

**DO NOT use this product in excess of the maximum operating pressure differential.** Such use could make discharge impossible (blocked).

**Use only under conditions in which no freeze-up will occur.** Freezing may damage the product, leading to fluid discharge, which may cause burns or other injury.

Refer to the product nameplate for detailed specifications.

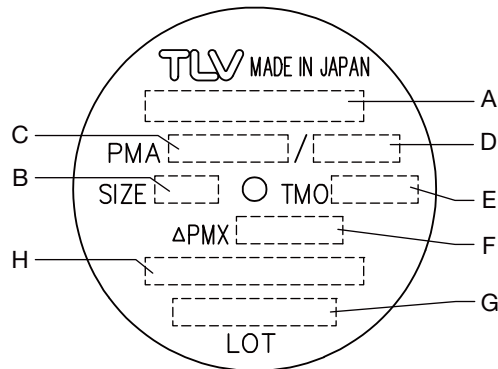

A	Model	E	Maximum Operating Temperature (TMO)
B	Nominal Diameter	F	Maximum Differential Pressure (PMX)
C	Maximum Allowable Pressure (PMA) <sup>01</sup>	G	Production Lot No.
D	Maximum Allowable Temperature (TMA)	H	Valve No. <sup>02</sup>

<sup>01</sup>Maximum allowable pressure (PMA) and maximum allowable temperature (TMA) are PRESSURE SHELL DESIGN CONDITIONS, **NOT** OPERATING CONDITIONS.

<sup>02</sup>Valve No. is displayed for products with options. This item is omitted from the nameplate when there are no options.

# Configuration

SS1NL-M2/SS1NH-M2

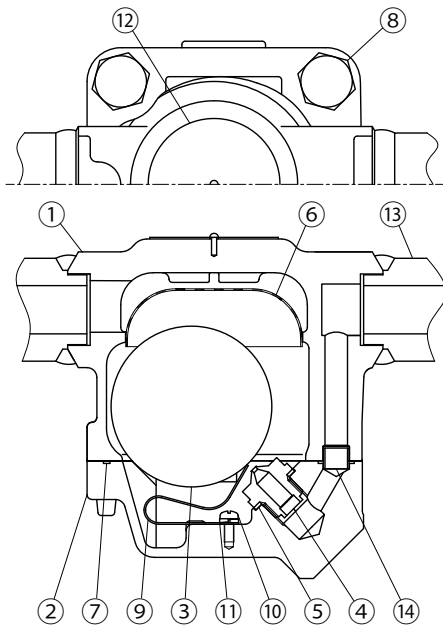

SS1VL-M2/SS1VH-M2

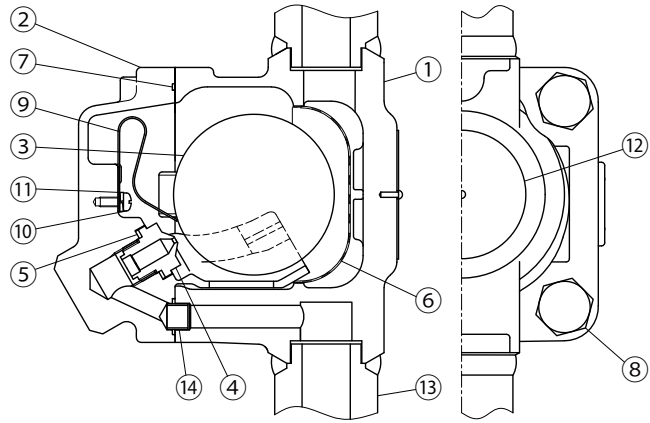

No.	Part Name	A <sup>01</sup>	B <sup>01</sup>	C <sup>02</sup>	No.	Part Name	A <sup>01</sup>	B <sup>01</sup>
1	Body				8	Cover Bolt		
2	Cover <sup>03</sup>				9	Air Vent Strip (Bimetal)		✓
3	Float			✓	10	Screw		✓
4	Valve Seat		✓		11	Spring Washer		✓
5	Valve Seat Gasket	✓	✓		12	Nameplate		
6	Screen		✓		13	Flange		
7	Cover Gasket	✓	✓		14	Connector		

<sup>01</sup>Replacement parts are available only in the following kits: A = Maintenance Kit, B = Repair Kit

<sup>02</sup>C = Float

<sup>03</sup>SS1VL-M2/SS1VH-M2: Includes attached float guides

# Installation



## Caution

**Install properly and DO NOT use this product outside the recommended operating pressure, temperature and other specification ranges.** Improper use may result in such hazards as damage to the product or malfunctions that may lead to serious accidents. Local regulations may restrict the use of this product to below the conditions quoted.

**Take measures to prevent people from coming into direct contact with product outlets.** Failure to do so may result in burns or other injury from the discharge of fluids.

**Do not use excessive force when connecting threaded pipes to the product.** Over-tightening may cause breakage leading to fluid discharge, which may cause burns or other injury.

Installation, inspection, maintenance, repairs, disassembly and adjustment and valve opening/closing should be carried out only by trained maintenance personnel.

1. Before installation, be sure to remove all protective seals.
2. Before installing the product, blow out the inlet piping to remove any piping scraps, dirt and oil. Close the inlet valve after blowdown.
3. Install the product so the arrow on the body is pointing in the direction of flow.
4. The product must be installed within the allowable angles of inclination of  $5^\circ$  horizontally and front-to-back.
5. Connect the outlet piping.
6. Open the inlet and outlet valves and ensure that the product functions properly.

If there is a problem, determine the cause using the "Troubleshooting" section in this manual.

SS1NL-M2/SS1NH-M2 (Horizontal Installation Model)

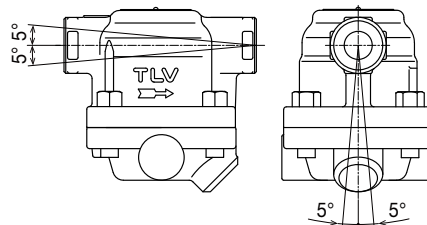

SS1VL-M2/SS1VH-M2 (Vertical Installation Model)

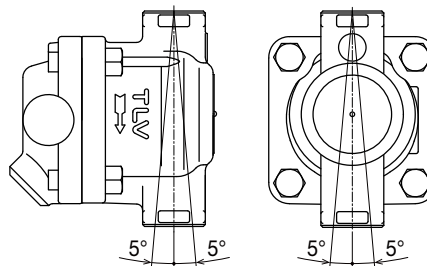

# Maintenance



## Caution

Take measures to prevent people from coming into direct contact with product outlets. Failure to do so may result in burns or other injury from the discharge of fluids.

Be sure to use only the recommended components when repairing the product, and NEVER attempt to modify the product in any way. Failure to observe these precautions may result in damage to the product and burns or other injury due to malfunction or the discharge of fluids.

## Operational Check

A visual inspection of the following items should be done on a daily basis to determine whether the product is operating properly or has failed. Periodically (at least biannually) the operation should also be checked by using diagnostic equipment such as a stethoscope, thermometer, TLV Pocket TrapMan or TLV TrapMan.

If the product should fail, it may cause damage to piping and equipment, resulting in faulty or low quality products or losses due to steam leakage.

Normal: Condensate is discharged continuously, together with flash steam, and the sound of flow can be heard.

Blocked (Discharge Impossible): No condensate is discharged. The product is quiet and makes no noise, and the surface temperature of the product is low.

Blowing: Live steam continually flows from the outlet and there is a continuous metallic sound.

Steam Leakage: Live steam is discharged through the product outlet together with condensate, accompanied by a high-pitched sound.

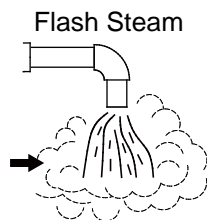

White jet containing water droplets

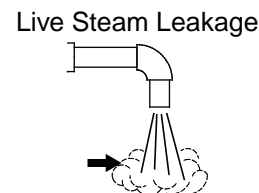

Clear, slightly bluish jet

## Parts Inspection

When parts have been removed, or during periodic inspections, use the following table to inspect the parts and replace any that are found to be defective.

Gaskets: Check for warping or damage

Screen: Check for clogging and corrosion

Float: Check for scratches or dents

Valve Seat: Check for damage

Valve Seat Opening: Check for rust, scale, oil film, wear or damage

# Disassembly/Reassembly



## Warning

**NEVER apply direct heat to the float.** The float may explode due to increased internal pressure, causing accidents leading to serious injury or damage to property and equipment.



## Caution

**When disassembling or removing the product, wait until the internal pressure equals atmospheric pressure and the surface of the product has cooled to room temperature.** Disassembling or removing the product when it is hot or under pressure may lead to discharge of fluids, causing burns, other injuries or damage.

Use the following procedures to remove components. Use the same procedures in reverse to reassemble.

(Installation, inspection, maintenance, repairs, disassembly, adjustment and valve opening/closing should be carried out only by trained maintenance personnel.)

## Detaching/Reattaching the Cover and Float

Part Name & No.		During Disassembly	During Reassembly
Cover Bolt	8	Remove with a socket wrench	Consult the table of tightening torques and tighten to the proper torque
Cover	2	Remove carefully; take care to prevent any damage to the float, which may fall out when the cover is removed	Make sure the sealing surfaces are clean, then reattach; SS1VL-M2/ SS1VH-M2 only: be careful not to bend the float guides (a)
Float	3	Remove, being careful not to scratch the polished surface	Place inside the body (or on the cover), being careful not to scratch its polished surface
Cover Gasket	7	SS1NH-M2/SS1VH-M2: Remove and clean sealing surfaces on the cover and body	Replace with a new gasket
		SS1NL-M2/SS1VL-M2: Remove only if damaged	Replace with a new gasket if damaged

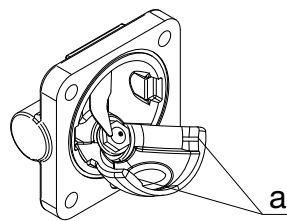

## Note

The float guides (a) are correctly positioned when shipped from the factory, so be careful when handling them. Tight sealing cannot be guaranteed if the float guides have been moved out of position.

## Disassembly/Reassembly of Components Inside the Body

Part Name & No.		During Disassembly	During Reassembly
Screen	6	Remove without bending; remove any scale build-up on the surface	Remove any scale from the surface before assembly. Align the screen groove and insert the screen (a).

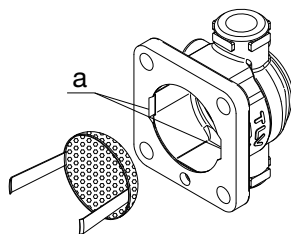

## Disassembly/Reassembly of Components Inside the Cover

Part Name & No.		During Disassembly	During Reassembly
Connector	14	Remove the connector	Remove the connector
Screw	10	Remove with a phillips screwdriver	Consult the table of tightening torques and tighten to the proper torque
Spring Washer	11		
Air Vent Strip (Bimetal)	9	Remove without bending	Insert without bending
Valve Seat	4	Remove with a socket wrench	Consult the table of tightening torques and tighten to the proper torque
Valve Seat Gasket	5	Remove the gasket and clean sealing surfaces	Replace with a new gasket

## Table of Tightening Torques

Part Name & No.		Torque N-m	Distance Across Flats mm
Cover Bolt	8	45	16
Valve Seat	4	20	13
Screw	10	0.3	+



### Note

- Coat all threaded portions with anti-seize.
- If drawings or other special documentation were supplied for the product, any torque given there takes precedence over values shown here.

# Exploded View

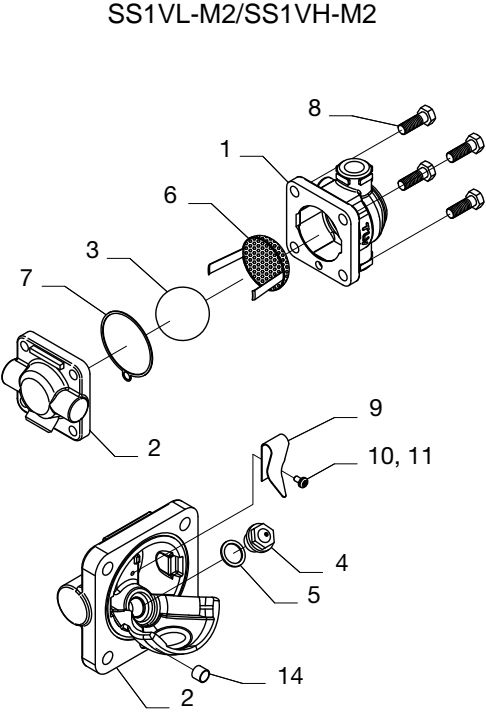
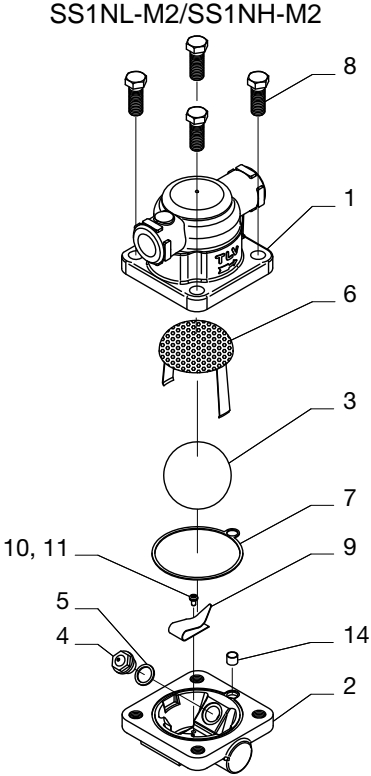

No.	Part Name	No.	Part Name
1	Body	8	Cover Bolt
2	Cover	9	Air Vent Strip (Bimetal)
3	Float	10	Screw
4	Valve Seat	11	Spring Washer
5	Valve Seat Gasket	12	Nameplate <sup>01</sup>
6	Screen	13	Flange <sup>01</sup>
7	Cover Gasket	14	Connector

<sup>01</sup>Not shown

# Troubleshooting



## Warning

**NEVER apply direct heat to the float.** The float may explode due to increased internal pressure, causing accidents leading to serious injury or damage to property and equipment.



## Caution

**When disassembling or removing the product, wait until the internal pressure equals atmospheric pressure and the surface of the product has cooled to room temperature.** Disassembling or removing the product when it is hot or under pressure may lead to discharge of fluids, causing burns, other injuries or damage.

When the product fails to operate properly, use the following table to locate the cause and remedy.

Problem	Cause	Remedy
No condensate is discharged (blocked) or discharge is poor	The float is damaged or filled with condensate	Replace with a new float
	The float is sticking to the valve seat	Clean parts
	The valve seat opening, screen or piping are clogged with rust and scale	Clean parts
	The capacity of the product is insufficient	Compare specifications and actual operating conditions
	The product operating pressure exceeds the maximum specified pressure, or whether there is insufficient pressure differential between the product inlet and outlet	Compare specifications and actual operating conditions
	Steam locking has occurred	Perform a bypass blowdown or close the product inlet valve and allow the product to cool
Steam is discharged or leaks from the outlet (blowing) (steam leakage)	The valve seat opening is clogged or there is rust or scale build-up on the surface of the float	Clean parts
	The valve seat is damaged	Replace with a new valve seat
	The float is damaged	Replace with a new float
	The installation is not correct	Correct the installation
	The air vent strip (bimetal) is damaged	Replace with a new bimetal strip
Product vibration	Lengthen the inlet piping and fasten it securely	
Steam is leaking from a place other than the outlet	Gasket deterioration or damage	Replace with new gaskets
	Improper tightening torque was used	Tighten to the proper torque



## Note

When replacing parts with new, use the parts list for reference, and replace with parts from the maintenance kit and/or repair kit. Please note that replacement parts are only available as part of a replacement parts kit.

# TLV EXPRESS LIMITED WARRANTY

Subject to the limitations set forth below, TLV CO., LTD., a Japanese corporation ("**TLV**"), warrants that products which are sold by it, TLV International Inc. ("**TII**") or one of its group companies excluding TLV Corporation (a corporation of the United States of America), (hereinafter the "**Products**") are designed and manufactured by TLV, conform to the specifications published by TLV for the corresponding part numbers (the "**Specifications**") and are free from defective workmanship and materials. The party from whom the Products were purchased shall be known hereinafter as the "**Seller**". With regard to products or components manufactured by unrelated third parties (the "**Components**"), TLV provides no warranty other than the warranty from the third party manufacturer(s), if any.

## Exceptions to Warranty

This warranty does not cover defects or failures caused by:

1. improper shipping, installation, use, handling, etc., by persons other than TLV, TII or TLV group company personnel, or service representatives authorized by TLV; or
2. dirt, scale or rust, etc.; or
3. improper disassembly and reassembly, or inadequate inspection and maintenance by persons other than TLV or TLV group company personnel, or service representatives authorized by TLV; or
4. disasters or forces of nature or Acts of God; or
5. abuse, abnormal use, accidents or any other cause beyond the control of TLV, TII or TLV group companies; or
6. improper storage, maintenance or repair; or
7. operation of the Products not in accordance with instructions issued with the Products or with accepted industry practices; or
8. use for a purpose or in a manner for which the Products were not intended; or
9. use of the Products in a manner inconsistent with the Specifications; or
10. use of the Products with Hazardous Fluids (fluids other than steam, air, water, nitrogen, carbon dioxide and inert gases (helium, neon, argon, krypton, xenon and radon)); or
11. failure to follow the instructions contained in the TLV Instruction Manual for the Product.

## Duration of Warranty

This warranty is effective for a period of one (1) year after delivery of Products to the first end user. Notwithstanding the foregoing, asserting a claim under this warranty must be brought within three (3) years after the date of delivery to the initial buyer if not sold initially to the first end user.

ANY IMPLIED WARRANTIES NOT NEGATED HEREBY WHICH MAY ARISE BY OPERATION OF LAW, INCLUDING THE IMPLIED WARRANTIES OF MERCHANTABILITY AND FITNESS FOR A PARTICULAR PURPOSE AND ANY EXPRESS WARRANTIES NOT NEGATED HEREBY, ARE GIVEN SOLELY TO THE INITIAL BUYER AND ARE LIMITED IN DURATION TO ONE (1) YEAR FROM THE DATE OF SHIPMENT BY THE SELLER.

## Exclusive Remedy

THE EXCLUSIVE REMEDY UNDER THIS WARRANTY, UNDER ANY EXPRESS WARRANTY OR UNDER ANY IMPLIED WARRANTIES NOT NEGATED HEREBY (INCLUDING THE IMPLIED WARRANTIES OF MERCHANTABILITY AND FITNESS FOR A PARTICULAR PURPOSE), IS **REPLACEMENT**; PROVIDED: (a) THE CLAIMED DEFECT IS

REPORTED TO THE SELLER IN WRITING WITHIN THE WARRANTY PERIOD, INCLUDING A DETAILED WRITTEN DESCRIPTION OF THE CLAIMED DEFECT AND HOW AND WHEN THE CLAIMED DEFECTIVE PRODUCT WAS USED; AND (b) THE CLAIMED DEFECTIVE PRODUCT AND A COPY OF THE PURCHASE INVOICE IS RETURNED TO THE SELLER, FREIGHT AND TRANSPORTATION COSTS PREPAID, UNDER A RETURN MATERIAL AUTHORIZATION AND TRACKING NUMBER ISSUED BY THE SELLER. ALL LABOR COSTS, SHIPPING COSTS, AND TRANSPORTATION COSTS ASSOCIATED WITH THE RETURN OR REPLACEMENT OF THE CLAIMED DEFECTIVE PRODUCT ARE SOLELY THE RESPONSIBILITY OF BUYER OR THE FIRST END USER. THE SELLER RESERVES THE RIGHT TO INSPECT ON THE FIRST END USER'S SITE ANY PRODUCTS CLAIMED TO BE DEFECTIVE BEFORE ISSUING A RETURN MATERIAL AUTHORIZATION. SHOULD SUCH INSPECTION REVEAL, IN THE SELLER'S REASONABLE DISCRETION, THAT THE CLAIMED DEFECT IS NOT COVERED BY THIS WARRANTY, THE PARTY ASSERTING THIS WARRANTY SHALL PAY THE SELLER FOR THE TIME AND EXPENSES RELATED TO SUCH ON-SITE INSPECTION.

### **Exclusion of Consequential and Incidental Damages**

IT IS SPECIFICALLY ACKNOWLEDGED THAT THIS WARRANTY, ANY OTHER EXPRESS WARRANTY NOT NEGATED HEREBY, AND ANY IMPLIED WARRANTY NOT NEGATED HEREBY, INCLUDING THE IMPLIED WARRANTIES OF MERCHANTABILITY AND FITNESS FOR A PARTICULAR PURPOSE, DO NOT COVER, AND NEITHER TLV, TII NOR ITS TLV GROUP COMPANIES WILL IN ANY EVENT BE LIABLE FOR, INCIDENTAL OR CONSEQUENTIAL DAMAGES, INCLUDING, BUT NOT LIMITED TO LOST PROFITS, THE COST OF DISASSEMBLY AND SHIPMENT OF THE DEFECTIVE PRODUCT, INJURY TO OTHER PROPERTY, DAMAGE TO BUYER'S OR THE FIRST END USER'S PRODUCT, DAMAGE TO BUYER'S OR THE FIRST END USER'S PROCESSES, LOSS OF USE, OR OTHER COMMERCIAL LOSSES. WHERE, DUE TO OPERATION OF LAW, CONSEQUENTIAL AND INCIDENTAL DAMAGES UNDER THIS WARRANTY, UNDER ANY OTHER EXPRESS WARRANTY NOT NEGATED HEREBY OR UNDER ANY IMPLIED WARRANTY NOT NEGATED HEREBY (INCLUDING THE IMPLIED WARRANTIES OF MERCHANTABILITY AND FITNESS FOR A PARTICULAR PURPOSE) CANNOT BE EXCLUDED, SUCH DAMAGES ARE EXPRESSLY LIMITED IN AMOUNT TO THE PURCHASE PRICE OF THE DEFECTIVE PRODUCT. THIS EXCLUSION OF CONSEQUENTIAL AND INCIDENTAL DAMAGES, AND THE PROVISION OF THIS WARRANTY LIMITING REMEDIES HEREUNDER TO REPLACEMENT, ARE INDEPENDENT PROVISIONS, AND ANY DETERMINATION THAT THE LIMITATION OF REMEDIES FAILS OF ITS ESSENTIAL PURPOSE OR ANY OTHER DETERMINATION THAT EITHER OF THE ABOVE REMEDIES IS UNENFORCEABLE, SHALL NOT BE CONSTRUED TO MAKE THE OTHER PROVISIONS UNENFORCEABLE.

### **Exclusion of Other Warranties**

THIS WARRANTY IS IN LIEU OF ALL OTHER WARRANTIES, EXPRESS OR IMPLIED, AND ALL OTHER WARRANTIES, INCLUDING BUT NOT LIMITED TO THE IMPLIED WARRANTIES OF MERCHANTABILITY AND FITNESS FOR A PARTICULAR PURPOSE, ARE EXPRESSLY DISCLAIMED.

### **Severability**

Any provision of this warranty which is invalid, prohibited or unenforceable in any jurisdiction shall, as to such jurisdiction, be ineffective to the extent of such invalidity, prohibition or unenforceability without invalidating the remaining provisions hereof, and any such invalidity, prohibition or unenforceability in any such jurisdiction shall not invalidate or render unenforceable such provision in any other jurisdiction.

# Service

For Service or Technical Assistance: Contact your TLV representative or your regional TLV office.

## In Europe:

### **TLV EURO ENGINEERING GmbH**

Daimler-Benz-Straße 16-18, 74915 Waibstadt, **Germany**

Tel: [49]-(0)7263-9150-0

### **TLV EURO ENGINEERING UK LTD.**

Units 7 & 8, Furlong Business Park, Bishops Cleeve,  
Gloucestershire GL52 8TW, **U.K.**

Tel: [44]-(0)1242-227223

### **TLV EURO ENGINEERING FRANCE SARL**

Parc d'Ariane 2, bât. C, 290 rue Ferdinand Perrier, 69800 Saint  
Priest, **France**

Tel: [33]-(0)4-72482222

Fax: [33]-(0)4-72482220

## In North America:

### **TLV CORPORATION**

13901 South Lakes Drive, Charlotte, NC 28273-6790, **U.S.A.**

Tel: [1]-704-597-9070

Fax: [1]-704-583-1610

### **TLV ENGINEERING S. A. DE C. V.**

Av. Jesús del Monte 39-B-1001, Col. Hda. de las Palmas,  
Huixquilucan, Edo. de México, 52763, **Mexico**

Tel: [52]-55-5359-7949

Fax: [52]-55-5359-7585

## In Oceania:

### **TLV PTY LIMITED**

Unit 8, 137-145 Rooks Road, Nunawading, Victoria 3131,

Tel: [61]-(0)3-9873 5610

Fax: [61]-(0)3-9873 5010

## Australia

## In East Asia:

### **TLV PTE LTD**

36 Kaki Bukit Place, #02-01/02, **Singapore** 416214

Tel: [65]-6747 4600

Fax: [65]-6742 0345

### **TLV SHANGHAI CO., LTD.**

5/F, Building 7, No.103 Caobao Road, Xuhui District, Shanghai,  
**China** 200233

Tel: [86]-(0)21-6482-8622

Fax: [86]-(0)21-6482-8623

### **TLV ENGINEERING SDN. BHD.**

No.16, Jalan MJ14, Taman Industri Meranti Jaya, 47120 Puchong,  
Selangor, **Malaysia**

Tel: [60]-3-8052-2928

Fax: [60]-3-8051-0899

### **TLV PRIVATE LIMITED**

252/94 (K-L) 17th Floor, Muang Thai-Phatra Complex Tower B,  
Rachadaphisek Road, Huaykwang, Bangkok 10310, **Thailand**

Tel: [66]-2-693-3799

Fax: [66]-2-693-3979

### **TLV INC.**

#1121, Seongnam Central Biz Tower 3, 208, Galmachi-ro,  
Jungwon-gu, Seongnam-si, Gyeonggi-do, 13216, **Korea**

Tel: [82]-(0)31-726-2105

Fax: [82]-(0)31-726-2195

## In the Middle East:

### **TLV ENGINEERING FZCO**

Building 9W, B163, PO Box 371684, Dubai Airport Free Zone,  
Dubai, **UAE**

Email: sales-me@tlv.co.jp

## In Other Countries:

### **TLV INTERNATIONAL, INC.**

881 Nagasuna, Noguchi, Kakogawa, Hyogo 675-8511, **Japan**

Tel: [81]-(0)79-427-1818

Fax: [81]-(0)79-425-1167

## Manufacturer:

### **TLV CO., LTD.**

881 Nagasuna, Noguchi, Kakogawa, Hyogo 675-8511, **Japan**

Tel: [81]-(0)79-427-1800

Fax: [81]-(0)79-422-2277