

ISO 9001
ISO14001



Manufacturer

TLV CO., LTD.

Kakogawa, Japan

is approved by LRQA Ltd. to ISO 9001:2001



Instruction Manual

Cycle Counter

Standard Models: C1CM/C1CF/C1SM/C1SF

ATEX/IECEX/UKEX-certified models: C1CM-EX/C1CF-EX/C1SM-EX/C1SF-EX

172-65599M-06

Publication date 9 July 2024

Copyright © 2024 TLV CO., LTD.

Table of Contents

Introduction 4
Safety Considerations 5
Operation 7
Specifications 9
Configuration 11
Installation 12
Troubleshooting 17
TLV EXPRESS LIMITED WARRANTY 20
Service 22



Important

This instruction manual has been edited for use with both standard and intrinsically safe models.

Introduction

Thank you for purchasing the TLV cycle counter.

This product has been thoroughly inspected before being shipped from the factory. When the product is delivered, before doing anything else, check the specifications and external appearance to make sure nothing is out of the ordinary. Also be sure to read this manual carefully before use and follow the instructions to be sure of using the product properly.

If detailed instructions for the special order specifications or options are not contained in this manual, please contact TLV for full details.

This instruction manual is intended for use with the model(s) listed on the front cover.

It is necessary not only for installation but for subsequent maintenance, disassembly/reassembly and troubleshooting. Please keep it in a safe place for future reference.

Safety Considerations

- Read this section carefully before use and be sure to follow the instructions.
- Installation, inspection, maintenance, repairs, disassembly, adjustment and valve opening/closing should be carried out only by trained maintenance personnel.
- The precautions listed in this manual are designed to ensure safety and prevent equipment damage and personal injury. For situations that may occur as a result of erroneous handling, three different types of cautionary items are used to indicate the degree of urgency and the scale of potential damage and danger: DANGER, WARNING and CAUTION.
- The three types of cautionary items above are very important for safety: be sure to observe all of them as they relate to installation, use, maintenance and repair. Furthermore, TLV accepts no responsibility for any accidents or damage occurring as a result of failure to observe these precautions.

Cautionary items and definitions



Danger

Indicates an urgent situation which poses a threat of death or serious injury



Warning

Indicates that there is a potential threat of death or serious injury



Caution

Indicates that there is a possibility of injury or equipment/product damage

Safety Consideration for the Product



Warning

C1CM, C1SM, C1CF, and C1SF are not explosion-proof.

Use only the intrinsically safe C1CM-EX, C1SM-EX, C1CF-EX, and C1SF-EX in hazardous areas. Product markings are provided on the nameplate attached on the product. The C1CM-EX, C1SM-EX, C1CF-EX, and C1SF-EX are compliant with:

ATEX: EN IEC 60079-0:2018, EN 60079-11:2012

IECEX: IEC 60079-0:2017 Ed. 7, IEC 60079-11:2011 Ed. 6

UKEX: BS EN IEC 60079-0:2018, BS EN 60079-11:2012

The C1CM-EX, C1SM-EX, C1CF-EX, and C1SF-EX meet the following standards for intrinsic safety:

- C1CM-EX, C1CF-EX

ATEX: $\text{C} \text{Cn} \text{nnn} \text{Ex} \text{I} \text{I} \text{B} \text{T}3/\text{T}2 \text{G} \text{b} \text{C} \text{M} \text{L} 18 \text{A} \text{T} \text{E} \text{X} 2179 \text{X}$

IECEX: Ex ib IIB T3/T2 Gb, IECEX CML 18.0094X

UKEX: Ex ib IIB T3/T2 Gb, CML 21UKEX2742X

- C1SM-EX, C1SF-EX

ATEX: $\text{C} \text{C} \text{nnnn} \text{Ex} \text{I} \text{I} \text{C} \text{T}3/\text{T}2 \text{G} \text{b} \text{D} \text{E} \text{K} \text{R} \text{A} 13 \text{A} \text{T} \text{E} \text{X} 0039$

IECEX: Ex ib IIC T3/T2 Gb, IECEX DEK 13.0004

UKEX: Ex ib IIC T3/T2 Gb, CML 21UKEX2642

For hazardous areas, the product should be selected and installed by trained personnel with knowledge of the hazardous locations/classifications. When using the product in hazardous area, please connect it to the earth in order to avoid the ignition from electrostatic charge.

**Caution**

Install properly and DO NOT use this product outside the recommended operating pressure, temperature and other specification ranges. Improper use may result in such hazards as damage to the product or malfunctions that may lead to serious accidents. Local regulations may restrict the use of this product to below the conditions quoted.

**Caution**

Make sure that the sensor body is properly tightened. Insufficient tightening may allow steam to blow out, resulting in burns.

**Caution**

When disassembling or removing the product, wait until the internal pressure equals atmospheric pressure and the surface of the product has cooled to room temperature. Disassembling or removing the product when it is hot or under pressure may lead to discharge of fluids, causing burns, other injuries or damage.

**Caution**

NEVER attempt to modify the product in any way. Failure to observe these precautions may result in damage to the product and burns or other injury due to malfunction or the discharge or fluids.

**Caution**

Use only under conditions in which no water hammer will occur. The impact of water hammer may damage the product, leading to fluid discharge, which may cause burns or other injury.

**Caution**

When installing the product, use the appropriate tool such as an adjustable wrench. Using the improper tool may lead to injury or damage to the product.

**Caution**

DO NOT disassemble/modify the product. This could damage the product and/or the built-in battery, or cause leakage of battery fluid, leading to burns or other injury. Battery cells are not user replaceable.

Operation

Cycle counter is a counter designed for use with GP series TLV PowerTraps. Cycle counter registers each cycling of the PowerTrap by using its sensor arm to detect the vertical movement of the PowerTrap's internal float. When the contact points of the reed switch inside the counter body (or the switch unit) connect, each cycling of the PowerTrap is counted.

There are two different types of cycle counter available.



Note

Cycle counter protrudes from the PowerTrap body when installed on the PowerTrap. Make sure to maintain sufficient installation space as described in the instruction manual for the PowerTrap. Do not put extra force onto the cycle counter when lifting the PowerTrap up (for disassembly or maintenance, etc.).

Counter Unit Type (with a built-in LCD display)

This type includes a built-in LCD display to display the number of pump cycles of the PowerTrap. Install the cycle counter using the installation hole on the PowerTrap.

Installation location

Models: C1CM/C1CM-EX

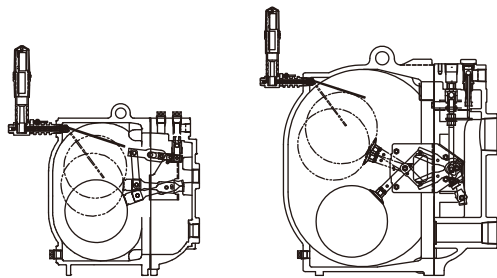

For GP10, GP10L, GP10M, GP14, GP14L,
GP14M

Models: C1CF/C1CF-EX

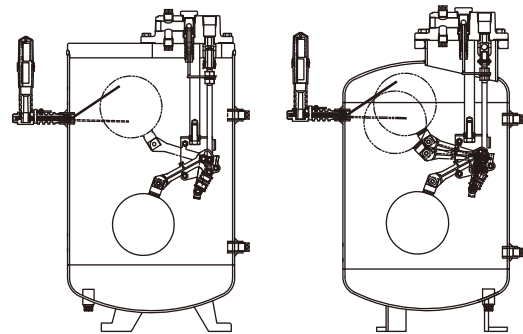

For GP10F, GP21F⁰¹

⁰¹Only available in some countries

Terminal Box Type (no display)

There is no display on this type. Use the product with a separately prepared self-powered counter, etc.

Installation location

Models: C1SM/C1SM-EX

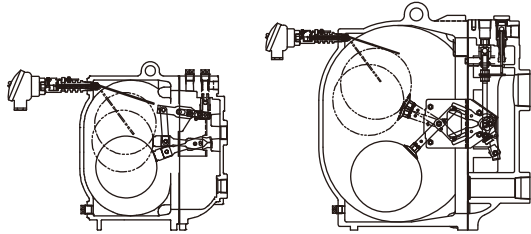

For GP10, GP10L, GP10M, GP14, GP14L,
GP14M

⁰¹Only available in some countries

Models: C1SF/C1SF-EX

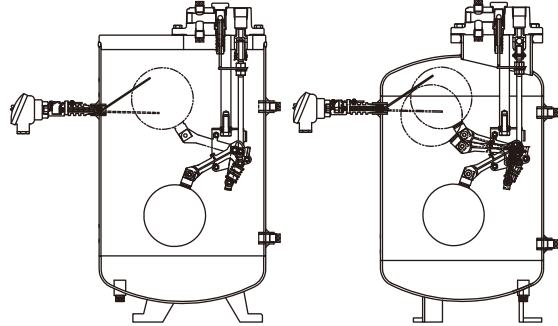

For GP10F, GP21F ⁰¹

Specifications



Caution

Install properly and DO NOT use this product outside the recommended operating pressure, temperature and other specification ranges. Improper use may result in such hazards as damage to the product or malfunctions that may lead to serious accidents. Local regulations may restrict the use of this product to below the conditions quoted.

C1C Series: Counter unit type ¹

| | |
|---|--|
| Model | C1CM, C1CF (for standard model) C1CM-EX, C1CF-EX (for intrinsically safe model) ⁰¹ |
| Installable PowerTrap models ⁰² | For standard model C1CM: GP10, GP14, GP10L, GP14L, GP10M, GP14M, GP system package C1CF: GP10F, GP21F, GP system package For intrinsically safe model C1CM-EX: GP10, GP14, GP10L, GP14L, GP10M, GP14M, GP system package C1CF-EX: GP10F, GP21F, GP system package |
| Connection | Screwed: R(PT) or NPT |
| Size | 15 mm |
| Maximum Operating Pressure (PMO) ⁰³ | 2.1 MPaG (21 barg) |
| Maximum Operating Temp. (TMO) ⁰³ | 220 °C |
| Maximum Allowable Pressure (PMA) ⁰⁴ | 2.1 MPaG (21 barg) |
| Maximum Allowable Temp. (TMA) ⁰⁴ | 260 °C |
| Applicable fluids ⁰⁵ | Steam condensate, water, steam, air, nitrogen |
| Protection class | IP65 ⁰⁶ |
| Ambient pressure/temperature | Atmospheric/-10 to 55 °C |
| Process temperature | T2: 220 °C/T3: 185 °C (for intrinsically safe models only) |
| Explosion-proof specifications (for intrinsically safe models only) | ATEX: $\text{C} \text{ nnnn } \text{Ex} \text{ II 2G Ex ib IIB T3/T2 Gb CML 18ATEX2179X}$ IECEx: Ex ib IIB T3/T2 Gb, CML 18.0094X UKEX: Ex ib IIB T3/T2 Gb, CML 21UKEX2742X |
| Display | 8-digit display LCD (can be reset) ⁰⁷ |
| Power Supply | Special built-in lithium battery (3.6 V) Battery life: Approx. 10 years (battery not replaceable ⁰⁸) |
| Weight | Approx. 660 g |
| Accessories | Counter resetter |

⁰¹The product is treated as IP20 class for intrinsic safety evaluation.

⁰²Can be installed on the GP PowerTrap, but it counts only the number of pump operations, and does not count the trap operations.

⁰³Maximum Operating Pressure (PMO) and Maximum Operating Temperature (TMO) are operating conditions for the inserted portion only.

⁰⁴Maximum Allowable Pressure (PMA) and Maximum Allowable Temperature (TMA) are DESIGN CONDITIONS FOR THE INSERTED PORTION, NOT OPERATING CONDITIONS.

⁰⁵Do not use with toxic, flammable or otherwise hazardous fluids.

⁰⁶Waterproofing of the wiring inlet should be carried out by the user using a waterproof cable gland, etc.

⁰⁷Once the counter is reset, the previous value is lost and cannot be recovered.

⁰⁸Once the battery is depleted the entire unit must be replaced as the battery cannot be taken out or replaced. In addition, as a used unit still contains its built-in battery, please return the unit to TLV or follow local regulations for disposal.

¹Repair parts are not supplied.

C1S Series: Terminal box type ²

| | |
|---|---|
| Model | C1SM, C1SF (for standard model) C1SM-EX, C1SF-EX (for intrinsically safe model) |
| Installable PowerTrap models ⁰¹ | C1SM/C1SM-EX: GP10, GP14, GP10L, GP14L, GP10M, GP14M, GP system package C1SF/C1SF-EX: GP10F GP21F, GP system package |
| Connection | Screwed R(PT) or NPT |
| Size | 15 mm |
| Maximum Operating Pressure (PMO) ⁰² | 2.1 MPaG (21 barg) |
| Maximum Operating Temp. (TMO) ⁰² | 220 °C |
| Maximum Allowable Pressure (PMA) ⁰³ | 2.1 MPaG (21 barg) |
| Maximum Allowable Temp. (TMA) ⁰³ | 260 °C |
| Applicable fluids ⁰⁴ | Steam condensate, water, steam, air, nitrogen |
| Protection class | IP65 ⁰⁵ |
| Ambient pressure/ temperature | Standard models: Atmospheric/-45 to 90 °C Intrinsically safe models: Atmospheric/-20 to 80 °C |
| Process temperature | T2: 0 to 220 °C/T3: 0 to 185 °C (for intrinsically safe models only) |
| Explosion-proof specifications (for intrinsically safe models only) | ATEX: $\text{C} \text{ nnnn } \text{Ex} \text{ II 2G Ex ib IIC T3/T2 Gb, DEKRA 13 ATEX 0039}$ IECEX: Ex ib IIC T3/T2 Gb, IECEX DEK 13.0004 UKEX: Ex ib IIC T3/T2 Gb, CML 21UKEX2642 |
| Contact specifications (Internal reed switch specifications) | Contact capacity: 1.0 VA Max. switching voltage: 24 V DC/AC Max. switching current: 0.1A <ul style="list-style-type: none"> • Maximum switching current/voltage is the maximum current/voltage that can be applied to the equipment. However, make sure the value of the switching voltage x switching current \leq 1.0 VA (contact capacity). • For the specifications and configuration of equipment that is connected externally, refer to the "Terminal box type" in the "Configuration" section. |
| Weight | Approx. 700 g |

⁰¹Can be installed on the GP PowerTrap, but it counts only the number of pump operations, and does not count the trap operations.

⁰²Maximum Operating Pressure (PMO) and Maximum Operating Temperature (TMO) are operating conditions for the inserted portion only.

⁰³Maximum Allowable Pressure (PMA) and Maximum Allowable Temperature (TMA) are DESIGN CONDITIONS FOR THE INSERTED PORTION, **NOT** OPERATING CONDITIONS.

⁰⁴Do not use with toxic, flammable or otherwise hazardous fluids.

⁰⁵Waterproofing of the wiring inlet should be carried out by the user using a waterproof cable gland, etc.

²Repair parts are not supplied.

Configuration

Counter unit type: C1CM/C1CM-EX/C1CF/C1CF-EX

Terminal box type: C1SM/C1SM-EX/C1SF/C1SF-EX

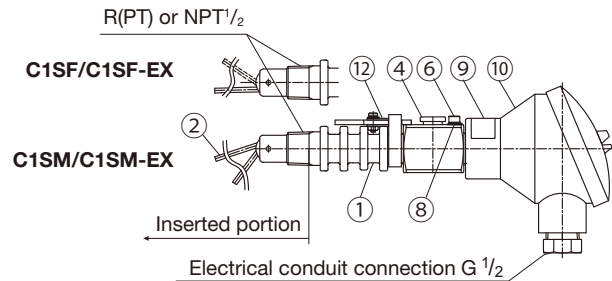
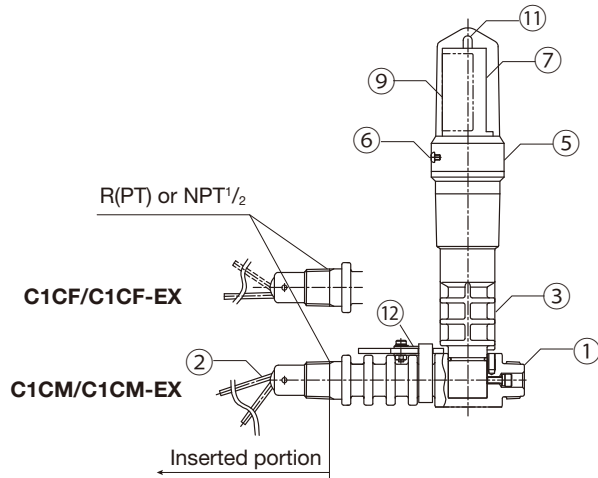

| No. | Part Name | No. | Part Name |
|-----|----------------------|-----|--------------------|
| 1 | Sensor Body | 7 | LCD Display |
| 2 | Sensor Arm | 8 | Washer |
| 3 | Counter Body | 9 | Nameplate |
| 4 | Switch Unit | 10 | Terminal Box |
| 5 | Cap | 11 | LED |
| 6 | Hex Socket Head Bolt | 12 | Magnet Booster Kit |



Note

- Cycle Counter cannot be installed on GP series PowerTraps insulated with an insulation thickness exceeding 40 mm.
- The year of manufacture is included in S. NO. (Serial Number) on the nameplate. Please contact TLV for details.
- R(PT) is equivalent to BSPT
- GP10, GP10L, GP10M, GP14, GP14L, GP14M and GP system packages cannot be equipped with a cycle counter and a liquid level gauge simultaneously but GP10F and GP21F can. GP10F and GP21F are only available in some countries.

Installation



Warning

C1CM, C1SM, C1CF, and C1SF are not explosion-proof. Use only the intrinsically safe C1CM-EX, C1SM-EX, C1CF-EX and C1SF-EX in hazardous areas. For hazardous areas, the product should be selected and installed by trained personnel with knowledge of the hazardous locations/classifications.



Caution

Install properly and DO NOT use this product outside the recommended operating pressure, temperature and other specification ranges. Improper use may result in such hazards as damage to the product or malfunctions that may lead to serious accidents. Local regulations may restrict the use of this product to below the conditions quoted.

Use only under conditions in which no water hammer will occur. The impact of water hammer may damage the product, leading to fluid discharge, which may cause burns or other injury.

Be sure to use only the recommended components when repairing the product, and NEVER attempt to modify the product in any way. Failure to observe these precautions may result in damage to the product and burns or other injury due to malfunction or the discharge of fluids.

Make sure that the sensor body is properly tightened. Insufficient tightening may allow steam to blow out, resulting in burns.

When disassembling or removing the product, wait until the internal pressure equals atmospheric pressure and the surface of the product has cooled to room temperature. Disassembling or removing the product when it is hot or under pressure may lead to discharge of fluids, causing burns, other injuries or damage.

Installation, inspection, maintenance, repairs, disassembly, adjustment and valve opening/closing should be carried out only by trained maintenance personnel.

An explanation for installing cycle counter onto the GP14M PowerTrap is given as an example. The same procedure should be followed for other models.

1. Remove the plug from the PowerTrap in reference with the installation position in the "Operation" section. Screw the cycle counter into the place where the plug has been removed on the PowerTrap by turning it clockwise 4 to 5 times.



Note

- Wrap the threaded portion of the sensor body with sealing tape for screwing into the PowerTrap. Ensure not to wrap the tape around any part of the sensor body other than the threaded portion. The cycle counter may not operate properly if tape is wrapped around a moving part such as the sensor arm.
- Do not use sealant. If sealant adheres to the moving part of the sensor arm it may interfere with the arm's movement.
- Sometimes the display on the counter unit type does not show "0" when delivered. The number can be reset after installation. Reset as needed. (Refer to the "Resetting the counter on the LCD display of the counter unit type" section described later in this manual.)

Make sure to remove any sealing tape or debris when removing the plug.

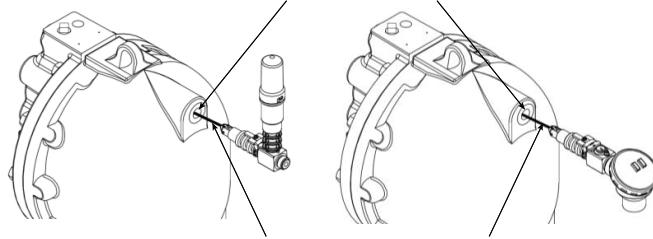

Make sure to install the sensor arm without bending.

For both the counter unit and terminal box types, use a tool such as an adjustable wrench to grip the square portion of the sensor body with distance across flats of 30 mm and screw the product in. Applying a force to any part of the product other than the square portion may deform or damage the product.

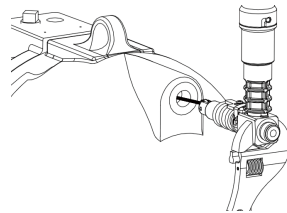

2. The following figure shows the product once installation is complete. Make sure to screw in the product with the LED on the tip is facing upwards (for C1CM/C1CM-EX) or the switch unit is facing upwards (for C1SM/C1SM-EX) within inclination of 5°.

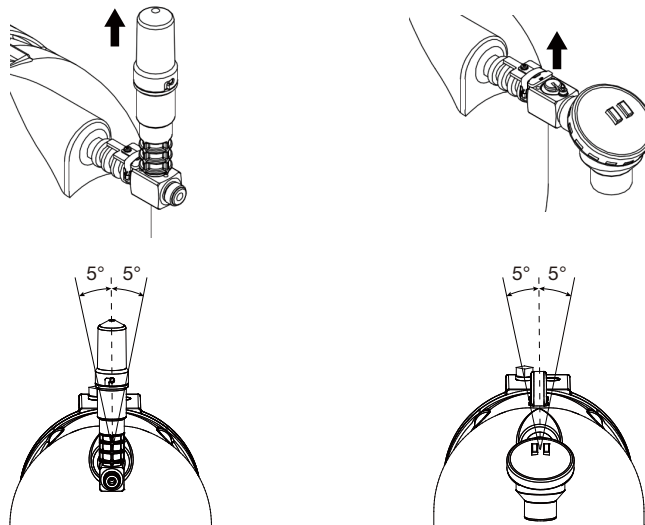

3. Before use, the wiring needs to be carried out for the terminal box type. Follow the figure shown below for the location of the wiring connections.
For the terminal box type, wiring is necessary to the terminal box. Before wiring, refer to the "Specifications" section to make sure that the supply power voltage meets these specifications. Make sure that the wires are securely connected to the terminal box using

the ring or the spade terminals. Waterproofing of the wiring inlet should be carried out using a waterproof cable gland, etc.

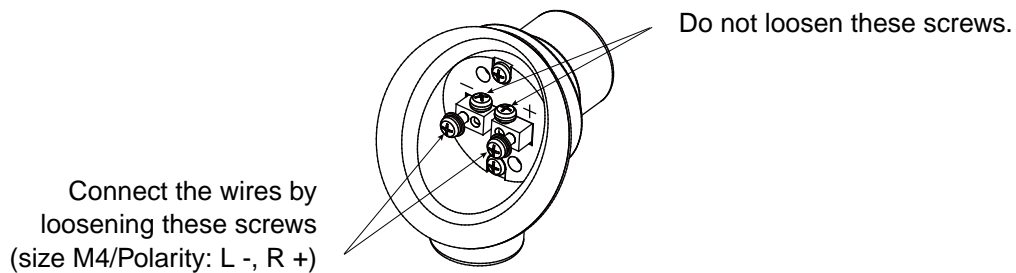

4. Make sure that the product is properly tightened before proceeding with the test operation.

For performing a test operation after the product has been installed, follow the procedure in the PowerTrap instruction manual.

Check motive medium supply piping and other piping connections before operation.

Operation should be carried out by trained personnel. If the display needs to be reset on the counter unit after the test operation, refer to the "Resetting the counter on the LCD display of the counter unit" section described later in this manual.

Adjusting the angle of the LCD display on the counter unit

The angle of the LCD display on the counter unit can be changed.



Note

In order to prevent burns, make sure the product is removed from the PowerTrap before starting to work.

1. Remove the hex socket head bolt (a) with a 2 mm hex key (b) on the counter body (c). Turn the cap (d) counterclockwise, then pull up to remove it from the counter body.

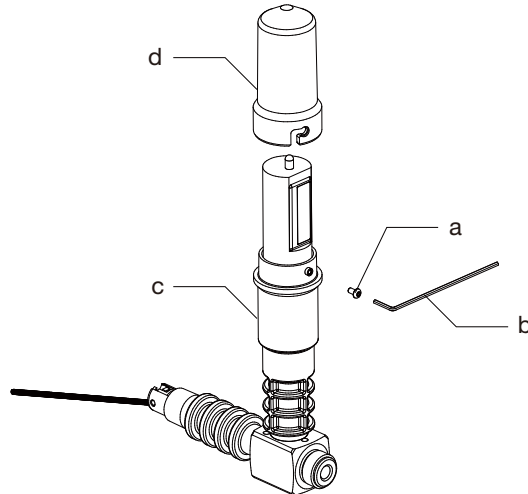

2. Once the cap is removed, turn the silicon-molded LCD display so that the LCD display is readable. After the adjustment is made, put the transparent cap back on and tighten the hex socket head bolt with a tightening torque of 0.5 N·m.

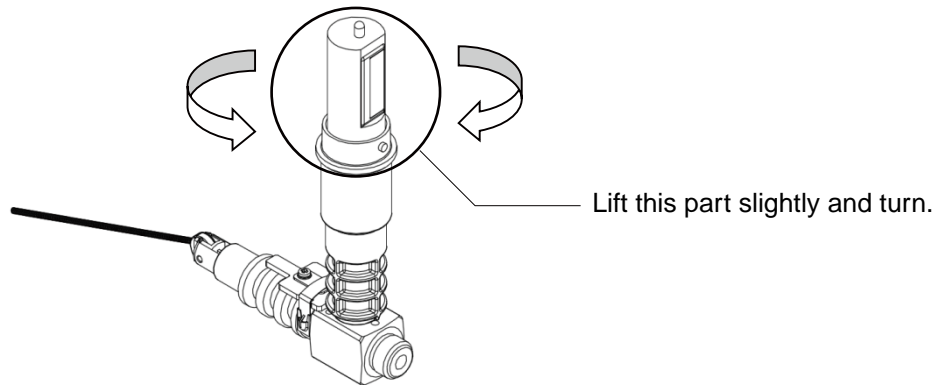

Note

Do not turn the LCD display part more than 360° to the left or right. Turning the display more than one rotation in either direction could cause disconnection of internal wiring or other malfunctions.

Resetting the counter on the LCD display of the counter unit

The numeric value displayed on the LCD of the counter unit can be reset.



Note

Once the counter is reset, the previous value is lost and cannot be recovered. In addition, failures of the PowerTrap caused by resetting the counter will not be covered under warranty.

Put the counter resetter (a) close to the back of the LCD display (b) as shown below. (The cap is removed in the figure below. The counter can be reset without removing the cap.) After the display clears momentarily, "0" will be displayed. Do not put the counter resetter close to the cycle counter other than for the purpose of resetting the counter display. Once the counter is reset to zero, it can not be returned to displaying the previous numeric value.

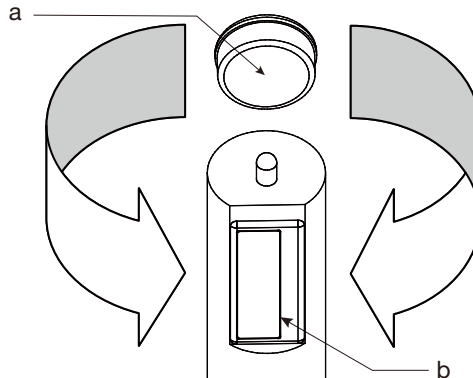

Magnet booster kit

If the cycle counter has been used in a high-temperature environment for a long period of time, the magnetic force of the reed switch becomes weaker, resulting in operational failure (the counter does not count).

For this reason, the magnet booster kit is installed on the upper part of the sensor body to prevent operational failure.

This booster kit has a built-in magnet to restore the magnetic force of the reed switch, preventing operational failure. Contact TLV in the event if the magnet booster kit falls from the cycle counter.

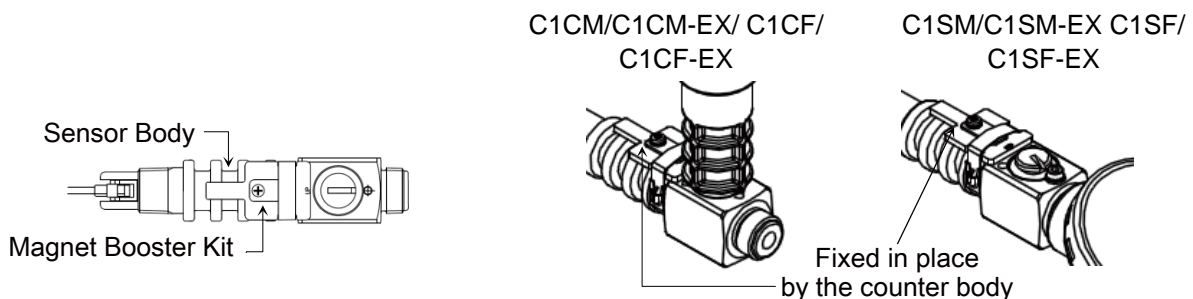

Troubleshooting



Caution

When disassembling or removing the product, wait until the internal pressure equals atmospheric pressure and the surface of the product has cooled to room temperature. Disassembling or removing the product when it is hot or under pressure may lead to discharge of fluids, causing burns, other injuries or damage.

When the product fails to operate properly, use the following table to locate the cause and remedy.

Counter Unit Type

| Problem | Cause | Remedy |
|--|---|--|
| Nothing is displayed on the LCD display | Battery has been completely discharged | Replace with a new counter unit (The battery itself cannot be replaced) |
| Cycle counter is not operating even though the PowerTrap is in operation (you can hear the snap action unit operating sound) | Sensitivity of the sensor is reduced | Adjust the sensitivity (See the "Adjusting the sensitivity for the counter unit type" section) |
| | Dirt or foreign matter has clogged the hinge part of the sensor arm, hindering its movement | Clean the moving area |

Terminal Box Type

| Problem | Cause | Remedy |
|--|---|---|
| Cycle counter is not operating even though the PowerTrap is in operation (you can hear the snap action unit operating sound) | Sensitivity of the sensor is reduced | Adjust the sensitivity (Refer to the "Adjusting the sensitivity for the terminal box type" section) |
| | Dirt or foreign matter has clogged the hinge part of the sensor arm, hindering its movement | Clean the moving area |
| | Improper wiring | Readjust the wiring |

If problems do not improve even after applying the remedies listed in "Troubleshooting", contact TLV.

Sensitivity adjustment for the counter unit type

When operating sounds can be heard from the PowerTrap however the cycle counter does not count or other symptoms appear, it is possible that the sensitivity of the sensor (the sensing accuracy of the reed switch) may have lowered due to aging of the product.

In such cases, the sensitivity of the sensor can be restored by readjusting the distance between the magnet built in to the sensor body and the built-in reed switch in the counter body (or the switch unit for the terminal box type) In this section, this operation is called sensitivity adjustment.

Make sure that the product is removed from the PowerTrap before you make adjustments. Take precautions against burns, etc. when removing the unit.

1. Loosen the hex socket head bolt holding the counter body in place.
2. Then rotate the counter body as shown in the figure on the next page while moving the sensor arm up and down. The counter body may be turned in either direction. Check the sensitivity by turning both ways (to the left and right). However do not turn more than 15° to the left or right.
3. Once the LED lights up in time with the movement of the sensor arm and has begun to count properly, the counter is considered to be operating normally.
4. Secure the counter by re-tightening the hex socket head bolt with a tightening torque of 1.5 N·m.

Loosen the hex socket head bolt with a 3 mm hex key and turn the counter body slightly to make sure that the counter is functioning properly.

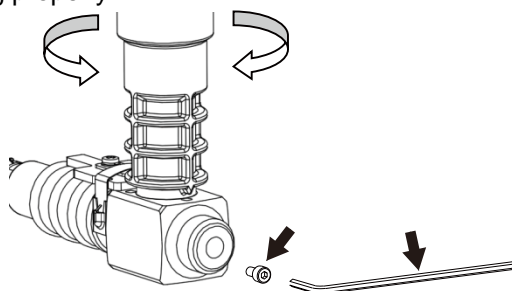

Adjust the counter body by twisting within 15° to the left or right. The angle should be adjusted based on the matching mark (a) and screw hole (b) on the body.

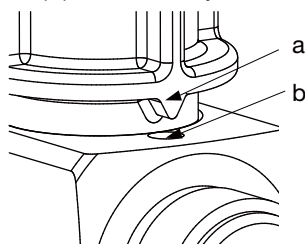

Note

- DO NOT turn the body more than 15° to the left or right when adjusting the sensitivity.
- When removing/installing the hex bolt, coat threaded portion with sealing agent to maintain waterproofing.

Sensitivity adjustment for the terminal box type

Make sure that the product is removed from the PowerTrap before you make sensitivity adjustments. Take precautions against burns, etc. when removing the unit.

To adjust the sensitivity, you can use a circuit tester, or else rewiring will be necessary after removing the unit from the PowerTrap. In this section, we will describe the adjustment method using a circuit tester.

First, set the range of the circuit tester so that the resistance measurement can be carried out, then connect the leads to the plus and minus terminals on the terminal box (refer to the "Installation" section).

Then move the sensor arm up and down and turn the switch unit little by little. The switch unit may be turned in either direction, however do not turn more than 15° to the left or right. When the resistance value of the circuit tester changes in time with the movement of the sensor arm, the unit is considered to be operating normally. After the adjustment is made, tighten the hex bolt with a tightening torque of 1.5 N·m.

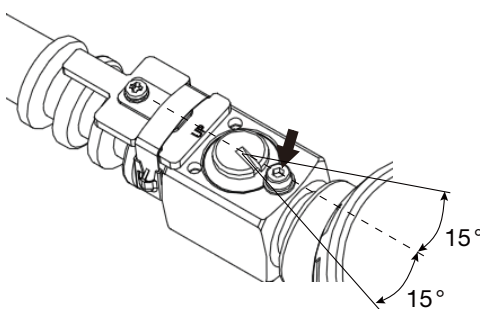

Note

- DO NOT turn the switch unit more than 15° to the left or right. The position of the hex socket head bolt should be used to determine the angle. **DO NOT turn the body more than 15° to the left or right when adjusting the sensitivity.**
- Loosen the head socket head bolt with a 3 mm hex key and turn the switch unit slightly with a coin, etc. to make sure that the counter is functioning properly.

TLV EXPRESS LIMITED WARRANTY

Subject to the limitations set forth below, TLV CO., LTD., a Japanese corporation ("**TLV**"), warrants that products which are sold by it, TLV International Inc. ("**TII**") or one of its group companies excluding TLV Corporation (a corporation of the United States of America), (hereinafter the "**Products**") are designed and manufactured by TLV, conform to the specifications published by TLV for the corresponding part numbers (the "**Specifications**") and are free from defective workmanship and materials. The party from whom the Products were purchased shall be known hereinafter as the "**Seller**". With regard to products or components manufactured by unrelated third parties (the "**Components**"), TLV provides no warranty other than the warranty from the third party manufacturer(s), if any.

Exceptions to Warranty

This warranty does not cover defects or failures caused by:

1. improper shipping, installation, use, handling, etc., by persons other than TLV, TII or TLV group company personnel, or service representatives authorized by TLV; or
2. dirt, scale or rust, etc.; or
3. improper disassembly and reassembly, or inadequate inspection and maintenance by persons other than TLV or TLV group company personnel, or service representatives authorized by TLV; or
4. disasters or forces of nature or Acts of God; or
5. abuse, abnormal use, accidents or any other cause beyond the control of TLV, TII or TLV group companies; or
6. improper storage, maintenance or repair; or
7. operation of the Products not in accordance with instructions issued with the Products or with accepted industry practices; or
8. use for a purpose or in a manner for which the Products were not intended; or
9. use of the Products in a manner inconsistent with the Specifications; or
10. use of the Products with Hazardous Fluids (fluids other than steam, air, water, nitrogen, carbon dioxide and inert gases (helium, neon, argon, krypton, xenon and radon)); or
11. failure to follow the instructions contained in the TLV Instruction Manual for the Product.

Duration of Warranty

This warranty is effective for a period of one (1) year after delivery of Products to the first end user. Notwithstanding the foregoing, asserting a claim under this warranty must be brought within three (3) years after the date of delivery to the initial buyer if not sold initially to the first end user.

ANY IMPLIED WARRANTIES NOT NEGATED HEREBY WHICH MAY ARISE BY OPERATION OF LAW, INCLUDING THE IMPLIED WARRANTIES OF MERCHANTABILITY AND FITNESS FOR A PARTICULAR PURPOSE AND ANY EXPRESS WARRANTIES NOT NEGATED HEREBY, ARE GIVEN SOLELY TO THE INITIAL BUYER AND ARE LIMITED IN DURATION TO ONE (1) YEAR FROM THE DATE OF SHIPMENT BY THE SELLER.

Exclusive Remedy

THE EXCLUSIVE REMEDY UNDER THIS WARRANTY, UNDER ANY EXPRESS WARRANTY OR UNDER ANY IMPLIED WARRANTIES NOT NEGATED HEREBY (INCLUDING THE IMPLIED WARRANTIES OF MERCHANTABILITY AND FITNESS FOR A PARTICULAR PURPOSE), IS **REPLACEMENT**; PROVIDED: (a) THE CLAIMED DEFECT IS

REPORTED TO THE SELLER IN WRITING WITHIN THE WARRANTY PERIOD, INCLUDING A DETAILED WRITTEN DESCRIPTION OF THE CLAIMED DEFECT AND HOW AND WHEN THE CLAIMED DEFECTIVE PRODUCT WAS USED; AND (b) THE CLAIMED DEFECTIVE PRODUCT AND A COPY OF THE PURCHASE INVOICE IS RETURNED TO THE SELLER, FREIGHT AND TRANSPORTATION COSTS PREPAID, UNDER A RETURN MATERIAL AUTHORIZATION AND TRACKING NUMBER ISSUED BY THE SELLER. ALL LABOR COSTS, SHIPPING COSTS, AND TRANSPORTATION COSTS ASSOCIATED WITH THE RETURN OR REPLACEMENT OF THE CLAIMED DEFECTIVE PRODUCT ARE SOLELY THE RESPONSIBILITY OF BUYER OR THE FIRST END USER. THE SELLER RESERVES THE RIGHT TO INSPECT ON THE FIRST END USER'S SITE ANY PRODUCTS CLAIMED TO BE DEFECTIVE BEFORE ISSUING A RETURN MATERIAL AUTHORIZATION. SHOULD SUCH INSPECTION REVEAL, IN THE SELLER'S REASONABLE DISCRETION, THAT THE CLAIMED DEFECT IS NOT COVERED BY THIS WARRANTY, THE PARTY ASSERTING THIS WARRANTY SHALL PAY THE SELLER FOR THE TIME AND EXPENSES RELATED TO SUCH ON-SITE INSPECTION.

Exclusion of Consequential and Incidental Damages

IT IS SPECIFICALLY ACKNOWLEDGED THAT THIS WARRANTY, ANY OTHER EXPRESS WARRANTY NOT NEGATED HEREBY, AND ANY IMPLIED WARRANTY NOT NEGATED HEREBY, INCLUDING THE IMPLIED WARRANTIES OF MERCHANTABILITY AND FITNESS FOR A PARTICULAR PURPOSE, DO NOT COVER, AND NEITHER TLV, TII NOR ITS TLV GROUP COMPANIES WILL IN ANY EVENT BE LIABLE FOR, INCIDENTAL OR CONSEQUENTIAL DAMAGES, INCLUDING, BUT NOT LIMITED TO LOST PROFITS, THE COST OF DISASSEMBLY AND SHIPMENT OF THE DEFECTIVE PRODUCT, INJURY TO OTHER PROPERTY, DAMAGE TO BUYER'S OR THE FIRST END USER'S PRODUCT, DAMAGE TO BUYER'S OR THE FIRST END USER'S PROCESSES, LOSS OF USE, OR OTHER COMMERCIAL LOSSES. WHERE, DUE TO OPERATION OF LAW, CONSEQUENTIAL AND INCIDENTAL DAMAGES UNDER THIS WARRANTY, UNDER ANY OTHER EXPRESS WARRANTY NOT NEGATED HEREBY OR UNDER ANY IMPLIED WARRANTY NOT NEGATED HEREBY (INCLUDING THE IMPLIED WARRANTIES OF MERCHANTABILITY AND FITNESS FOR A PARTICULAR PURPOSE) CANNOT BE EXCLUDED, SUCH DAMAGES ARE EXPRESSLY LIMITED IN AMOUNT TO THE PURCHASE PRICE OF THE DEFECTIVE PRODUCT. THIS EXCLUSION OF CONSEQUENTIAL AND INCIDENTAL DAMAGES, AND THE PROVISION OF THIS WARRANTY LIMITING REMEDIES HEREUNDER TO REPLACEMENT, ARE INDEPENDENT PROVISIONS, AND ANY DETERMINATION THAT THE LIMITATION OF REMEDIES FAILS OF ITS ESSENTIAL PURPOSE OR ANY OTHER DETERMINATION THAT EITHER OF THE ABOVE REMEDIES IS UNENFORCEABLE, SHALL NOT BE CONSTRUED TO MAKE THE OTHER PROVISIONS UNENFORCEABLE.

Exclusion of Other Warranties

THIS WARRANTY IS IN LIEU OF ALL OTHER WARRANTIES, EXPRESS OR IMPLIED, AND ALL OTHER WARRANTIES, INCLUDING BUT NOT LIMITED TO THE IMPLIED WARRANTIES OF MERCHANTABILITY AND FITNESS FOR A PARTICULAR PURPOSE, ARE EXPRESSLY DISCLAIMED.

Severability

Any provision of this warranty which is invalid, prohibited or unenforceable in any jurisdiction shall, as to such jurisdiction, be ineffective to the extent of such invalidity, prohibition or unenforceability without invalidating the remaining provisions hereof, and any such invalidity, prohibition or unenforceability in any such jurisdiction shall not invalidate or render unenforceable such provision in any other jurisdiction.

Service

For Service or Technical Assistance: Contact your TLV representative or your regional TLV office.

In Europe:

TLV EURO ENGINEERING GmbH

Daimler-Benz-Straße 16-18, 74915 Waibstadt, **Germany**

Tel: [49]-(0)7263-9150-0

TLV EURO ENGINEERING UK LTD.

Units 7 & 8, Furlong Business Park, Bishops Cleeve,
Gloucestershire GL52 8TW, **U.K.**

Tel: [44]-(0)1242-227223

TLV EURO ENGINEERING FRANCE SARL

Parc d'Ariane 2, bât. C, 290 rue Ferdinand Perrier, 69800 Saint
Priest, **France**

Tel: [33]-(0)4-72482222

Fax: [33]-(0)4-72482220

In North America:

TLV CORPORATION

13901 South Lakes Drive, Charlotte, NC 28273-6790, **U.S.A.**

Tel: [1]-704-597-9070

Fax: [1]-704-583-1610

TLV ENGINEERING S. A. DE C. V.

Av. Jesús del Monte 39-B-1001, Col. Hda. de las Palmas,
Huixquilucan, Edo. de México, 52763, **Mexico**

Tel: [52]-55-5359-7949

Fax: [52]-55-5359-7585

In Oceania:

TLV PTY LIMITED

Unit 8, 137-145 Rooks Road, Nunawading, Victoria 3131,

Tel: [61]-(0)3-9873 5610

Fax: [61]-(0)3-9873 5010

Australia

In East Asia:

TLV PTE LTD

36 Kaki Bukit Place, #02-01/02, **Singapore** 416214

Tel: [65]-6747 4600

Fax: [65]-6742 0345

TLV SHANGHAI CO., LTD.

5/F, Building 7, No.103 Caobao Road, Xuhui District, Shanghai,
China 200233

Tel: [86]-(0)21-6482-8622

Fax: [86]-(0)21-6482-8623

TLV ENGINEERING SDN. BHD.

No.16, Jalan MJ14, Taman Industri Meranti Jaya, 47120 Puchong,
Selangor, **Malaysia**

Tel: [60]-3-8052-2928

Fax: [60]-3-8051-0899

TLV PRIVATE LIMITED

252/94 (K-L) 17th Floor, Muang Thai-Phatra Complex Tower B,
Rachadaphisek Road, Huaykwang, Bangkok 10310, **Thailand**

Tel: [66]-2-693-3799

Fax: [66]-2-693-3979

TLV INC.

#302-1 Bundang Technopark B, 723 Pangyo-ro, Bundang,
Seongnam, Gyeonggi, 13511, **Korea**

Tel: [82]-(0)31-726-2105

Fax: [82]-(0)31-726-2195

In the Middle East:

TLV ENGINEERING FZCO

Building 9W, B163, PO Box 371684, Dubai Airport Free Zone,
Dubai, **UAE**

Email: sales-me@tlv.co.jp

In Other Countries:

TLV INTERNATIONAL, INC.

881 Nagasuna, Noguchi, Kakogawa, Hyogo 675-8511, **Japan**

Tel: [81]-(0)79-427-1818

Fax: [81]-(0)79-425-1167

Manufacturer:

TLV CO., LTD.

881 Nagasuna, Noguchi, Kakogawa, Hyogo 675-8511, **Japan**

Tel: [81]-(0)79-427-1800

Fax: [81]-(0)79-422-2277