



Manufacturer

TLV CO., LTD.
Kakogawa, Japan
It approved by LRQA Ltd. to ISO 9001/14001



TLV[®]

Instruction Manual

PowerTrap[®]

GP5C

Manufacturer

TLV CO., LTD.

881 Nagasuna, Noguchi, Kakogawa, Hyogo, 675-8511, Japan
Tel: [81]-(0)79-427-1800 Fax: [81]-(0)79-422-2277

Copyright © 2025 by TLV CO., LTD. All rights reserved

TLV CORPORATION

Contents

Introduction.....	2
Safety Considerations	3
General Description.....	6
Application.....	6
Operation.....	7
Specifications	8
Configuration	9
Installation	10
Open System Piping (Steam System Example).....	10
Installation Procedure	11
Sizing the Condensate Receiver.....	15
Maintenance Space and Tolerance Angle for Installation	16
Operation and Periodic Inspection	17
Operation.....	17
Periodic Inspection and Diagnosis	18
Disassembly/Reassembly	19
Replacement Parts	20
Recommended Tools List for Disassembly/Reassembly.....	21
1. Before Removing/Reattaching	22
2. Removing/Reattaching the Body from/to the Cover	22
3. Removing/Reattaching the Snap-action Unit.....	23
4. Removing/Reattaching Each Unit	24
Troubleshooting.....	26
Determining the Problem from the Symptoms.....	26
Types of Failure and their Causes	27
Causes and Corrective Measures.....	28
TLV EXPRESS LIMITED WARRANTY	30

Introduction

Thank you for purchasing the TLV PowerTrap.

This product has been thoroughly inspected before being shipped from the factory. When the product is delivered, before doing anything else, check the specifications and external appearance to make sure nothing is out of the ordinary. Also, be sure to read this manual carefully before use and follow the instructions to be sure of using the product properly.







If detailed instructions for special order specifications or options not contained in this manual are required, please contact TLV for full details.

This instruction manual is intended for use with the model listed on the front cover. It is necessary not only for installation, but for subsequent maintenance, disassembly/reassembly and troubleshooting. Please keep it in a safe place for future reference.

Safety Considerations

- Read this section carefully before use and be sure to follow the instructions.
- Installation, inspection, maintenance, repairs, disassembly, adjustment and valve opening/closing should be carried out only by trained maintenance personnel.
- The precautions listed in this manual are designed to ensure safety and prevent equipment damage and personal injury. For situations that may occur as a result of erroneous handling, three different types of cautionary items are used to indicate the degree of urgency and the scale of potential damage and danger: DANGER, WARNING and CAUTION.
- The three types of cautionary items above are very important for safety: be sure to observe all of them as they relate to installation, use, maintenance and repair. Furthermore, TLV accepts no responsibility for any accidents or damage occurring as a result of failure to observe these precautions.

Symbols

	Indicates a DANGER, WARNING or CAUTION item.
	Indicates an urgent situation which poses a threat of death or serious injury
	Indicates that there is a potential threat of death or serious injury
	Indicates that there is a possibility of injury or equipment / product damage
	NEVER apply direct heat to the float. The float may explode due to increased internal pressure, causing accidents leading to serious injury or damage to property and equipment.
	Install properly and DO NOT use this product outside the recommended operating pressure, temperature and other specification ranges. Improper use may result in such hazards as damage to the product or malfunctions that may lead to serious accidents. Local regulations may restrict the use of this product to below the conditions quoted.
	Use hoisting equipment for heavy objects (weighing approximately 20 kg (44 lb) or more). Failure to do so may result in back strain or other injury if the object should fall.
	Take measures to prevent people from coming into direct contact with product outlets. Failure to do so may result in burns or other injury from the discharge of fluids.

When disassembling or removing the product, wait until the internal pressure equals atmospheric pressure and the surface of the product has cooled to room temperature.

Disassembling or removing the product when it is hot or under pressure may lead to discharge of fluids, causing burns, other injuries or damage.

Continued on next page



Be sure to use only the recommended components when repairing the product, and NEVER attempt to modify the product in any way.

Failure to observe these precautions may result in damage to the product and burns or other injury due to malfunction or the discharge of fluids.

Do not use excessive force when connecting threaded pipes to the product.

Over-tightening may cause breakage leading to fluid discharge, which may cause burns or other injury.

Use only under conditions in which no freeze-up will occur.

Freezing may damage the product, leading to fluid discharge, which may cause burns or other injury.

Use only under conditions in which no water hammer will occur.

The impact of water hammer may damage the product, leading to fluid discharge, which may cause burns or other injury.

Take measures to ensure the proper handling, such as recovery or dilution, of hazardous fluids discharged at product outlets.

Outflow of fluid or fluid leaks may lead to hazards such as flammable conditions or corrosion, which may result in injury, fires, damage or other accidents.

- Be sure to install a vent pipe and an overflow pipe. Failure to install an overflow pipe is dangerous, as condensate may spurt from the vent pipe and could result in burns and other injuries.

- Pipe the vent pipe and the overflow pipe to a safe place such as a pit.

- After completing all piping work based on the designed piping system, make sure that all piping connections are properly and securely tightened and gaskets are properly installed.

- During the initial operation of the system, a large amount of condensate may flow into the PowerTrap and temporarily cause it to overflow. Open the inlet valve slowly to allow condensate to flow into the trap slowly.

- Repairs or disassembly of the piping, adjustment and valve opening/closing should be carried out only by trained maintenance personnel.

- Before connecting piping or disassembling the product, close the inlet and outlet valves and make every effort to reduce the internal pressure to cool the product to room temperature.

•When disassembling connecting parts, remove pipes and bolts slowly to prevent condensate from suddenly flowing out in the event of residual pressure inside the product.

Disassembling or removing the product when it is hot or under pressure may lead to discharge of fluids, causing burns, other injuries or damage.

General Description



Install properly and **DO NOT** use this product outside the recommended operating pressure, temperature and other specification ranges. Improper use may result in such hazards as damage to the product or malfunctions which may lead to serious accidents. Local regulations may restrict the use of this product to below the conditions quoted.

Application

The PowerTrap is used to discharge liquid from low-pressure areas to high-pressure areas, or from lower to higher elevations.

The PowerTrap GP5C has an integrated pumping function that can eliminate and pump out condensate even if condensate cannot be discharged due to very low supply steam pressure because of reduced load in the steam-using equipment (this phenomenon is referred to in this document as 'stall').

The GP5C can also discharge the accumulated condensate when the steam-using equipment stops operation, and prevent water hammer when it re-starts operation.

There are two types of delivery systems (piping methods): the closed system and the open system. The PowerTrap GP5C you have purchased is a suitable model for the open system.

Check to make sure that the PowerTrap model purchased is suitable for use on the type of system that is being planned for installation.

Type of System	Closed System	Open System
System Overview		
Features	<ul style="list-style-type: none"> · There is no piping system that opens to the atmosphere and the condensate of 100 °C (212 °F) or more can be recovered · No venting of flash steam · Small reservoir compared to the open system · Use with vacuum equipment possible 	<ul style="list-style-type: none"> · There is a piping system that opens to the atmosphere and the condensate of 100 °C (212 °F) or less can be recovered · Collection of condensate from multiple equipment possible · Can be used where trap is lower than receiver, such as equipment situated near grade (providing there is sufficient differential pressure)
Notes	<ul style="list-style-type: none"> · Only one piece of equipment possible per system · Equipment has minimum height requirement to ensure that condensate flows naturally, by gravity. (GT5C: approximately 0.3 m (12 in)) 	<ul style="list-style-type: none"> · Separate steam trap required for each piece of equipment · Requires venting pipe to discharge flash steam to atmosphere
Model	PowerTrap with built-in trap GT5C	PowerTrap GP5C

Operation



Take measures to prevent people from coming into direct contact with product outlets. Failure to do so may result in burns or other injury from the discharge of fluids.

- (1) When condensate flows from the condensate inlet pipe through the inlet check valve into the body of the unit, the air in the body escapes through the exhaust valve (which equalizes the internal pump pressure to the pressure of the condensate source) and the float rises as shown in (A) below.
- (2) When the float rises to its high level, the push rod on the snap-action unit rises quickly, simultaneously closing the exhaust valve and opening the intake (motive medium) valve. The pressure supplied by the motive medium causes the internal pressure in the unit to become greater than the back pressure. The inlet check valve closes and the outlet check valve is pushed open, thus discharging the condensate in the unit through the outlet pipe, as shown in (B) below.
- (3) As a result of the condensate in the unit being discharged, the water level in the unit drops and the float descends. When the float reaches its low level, the push rod on the snap-action unit moves down quickly, simultaneously opening the exhaust valve and closing the intake (motive medium) valve and the status reverts to that shown in (A) below.

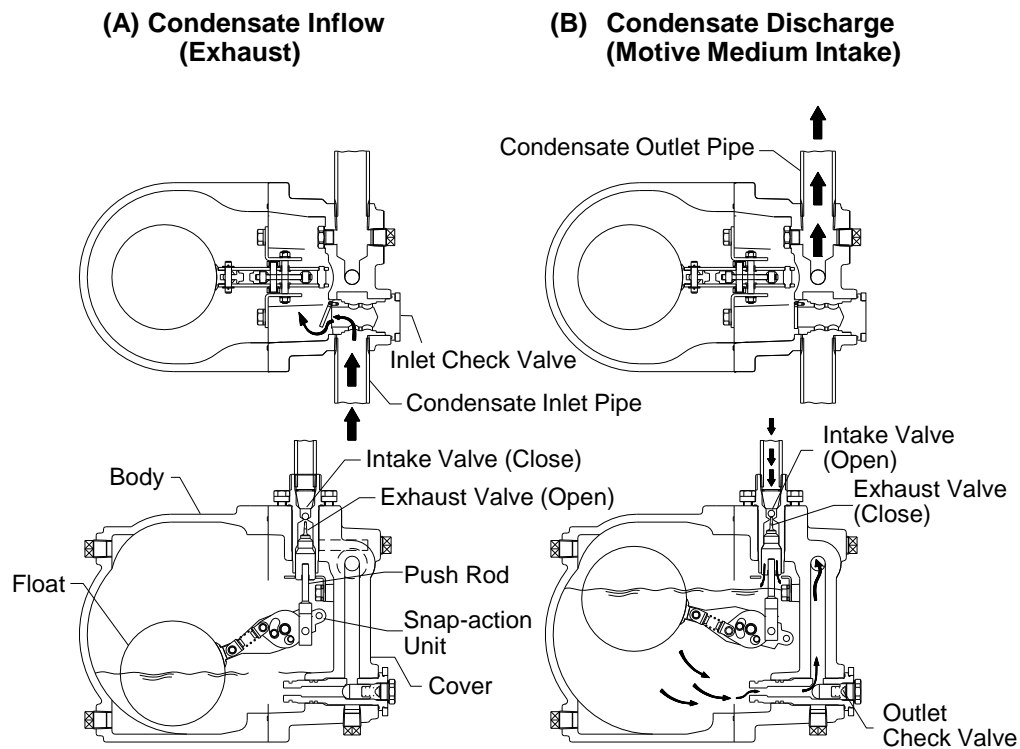

Specifications



Install properly and **DO NOT** use this product outside the recommended operating pressure, temperature and other specification ranges. Improper use may result in such hazards as damage to the product or malfunctions which may lead to serious accidents. Local regulations may restrict the use of this product to below the conditions quoted.



Use only under conditions in which no freeze-up will occur. Freezing may damage the product, leading to fluid discharge, which may cause burns or other injury.

Refer to the product nameplate for detailed specifications.

Body Material: Cast Iron

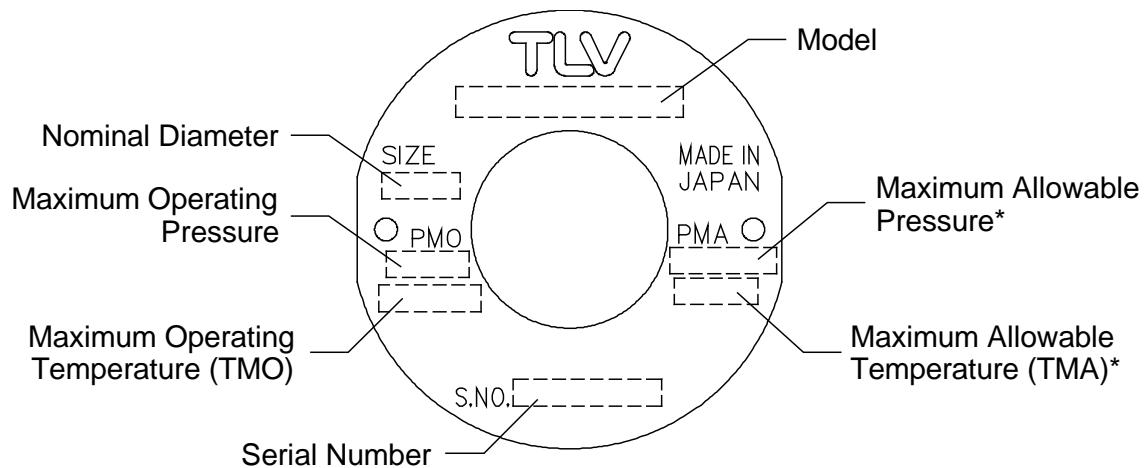

Body Material: Stainless Steel

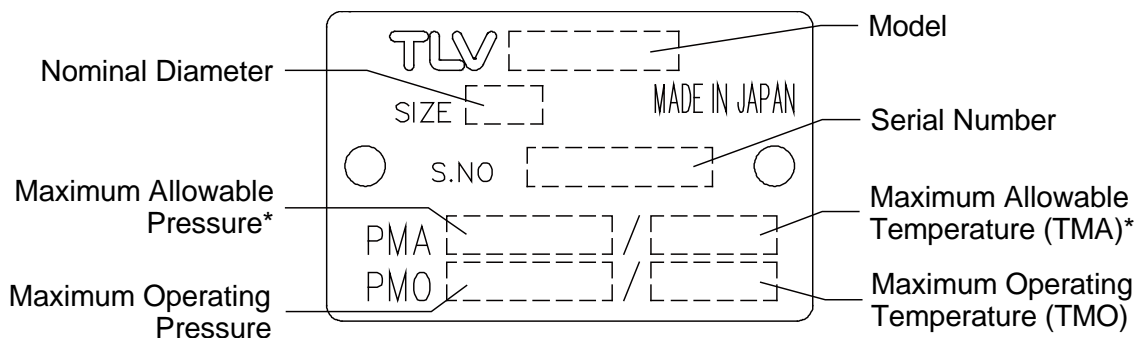

* Maximum allowable pressure (PMA) and maximum allowable temperature (TMA) are PRESSURE SHELL DESIGN CONDITIONS, **NOT** OPERATING CONDITIONS.

Configuration

GP5C

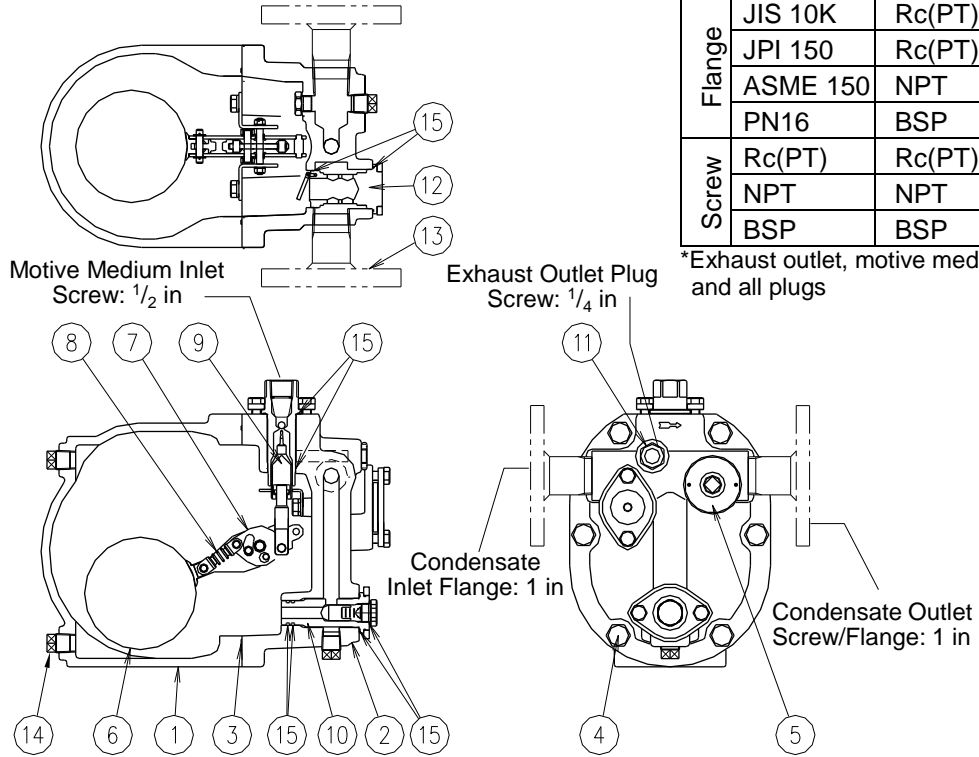

		Condensate Inlet/Outlet	Screwed Connection*
Flange	JIS 10K	Rc(PT)	Rc(PT)
	JPI 150	Rc(PT)	Rc(PT)
	ASME 150	NPT	NPT
	PN16	BSP	BSP
Screw		Rc(PT)	Rc(PT)
		NPT	NPT
		BSP	BSP

*Exhaust outlet, motive medium inlet and all plugs

No.	Parts	Maintenance Kit	Repair Kit ^{*1}					Float	Snap-action Spring
			A	B	C	D	E		
1	Body								
2	Cover								
3	Cover Gasket	✓							
4	Cover Bolt								
5	Nameplate								
6	Float						✓		
7	Snap-action Unit				✓ ^{*2}				
8	Snap-action Spring							✓	
9	Intake-Exhaust Valve Unit		✓						
10	Outlet Check Valve Unit					✓			
11	Exhaust Plug			✓					
12	Inlet Check Valve Unit						✓		
13	(Flange)								
14	Plug (for drainage)								
15	Seal Set	✓							

For details, please refer to "Replacement Parts".

^{*1} The maintenance kit should be purchased along with a repair kit or other parts, as gaskets might be required.

^{*2} A snap-action spring is also contained in the snap-action unit.

Installation



Install properly and **DO NOT** use this product outside the recommended operating pressure, temperature and other specification ranges. Improper use may result in such hazards as damage to the product or malfunctions which may lead to serious accidents. Local regulations may restrict the use of this product to below the conditions quoted.



Use hoisting equipment for heavy objects (weighing approximately 20 kg (44 lb) or more). Failure to do so may result in back strain or other injury if the object should fall.



Take measures to prevent people from coming into direct contact with product outlets. Failure to do so may result in burns or other injury from the discharge of fluids.



Do not use excessive force when connecting threaded pipes to the product. Over-tightening may cause breakage leading to fluid discharge, which may cause burns or other injury.



Use only under conditions in which no water hammer will occur. The impact of water hammer may damage the product, leading to fluid discharge, which may cause burns or other injury.

Open System Piping (Steam System Example)

For non-standard options, please refer to the additional instruction manual(s) provided. The following 4 pipes shall be connected to the GP5C: condensate inlet pipe, condensate outlet pipe, motive medium supply pipe and exhaust pipe. Refer to "Sizing the Condensate Receiver Pipe" for the size of the condensate inlet pipe [Si] (length of Dh).

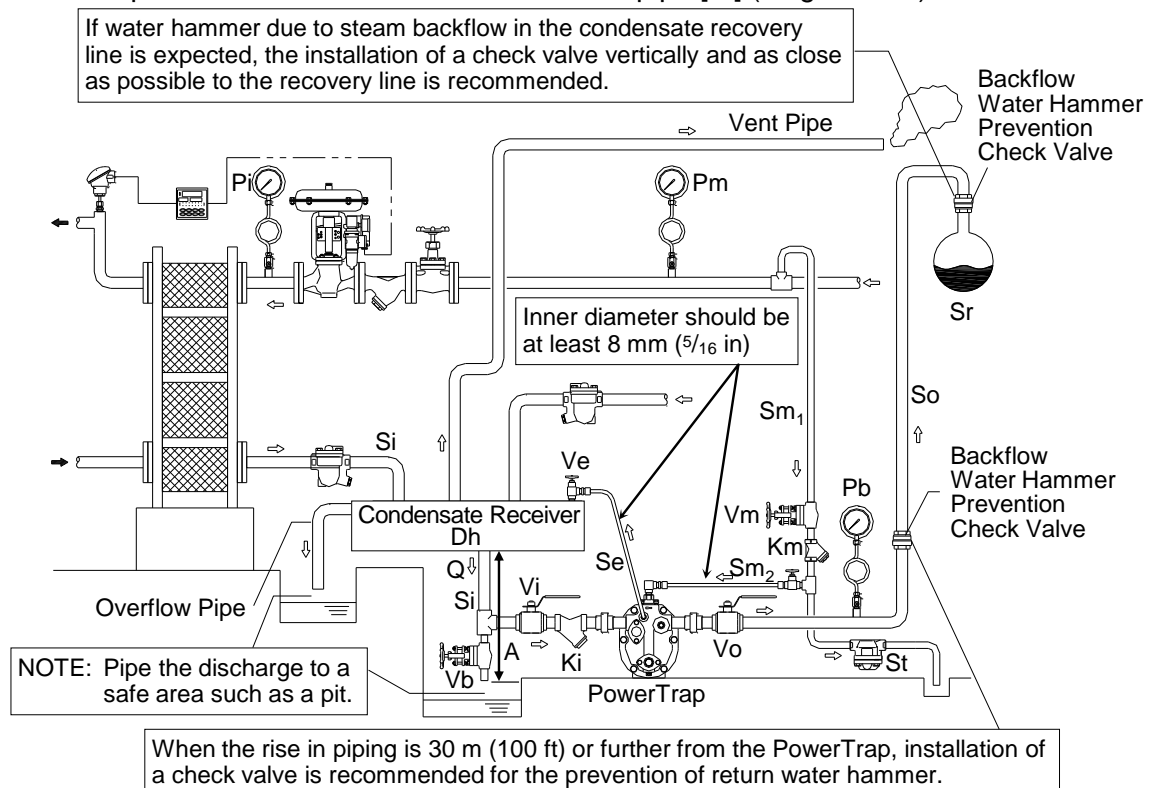

Q	Pumped Medium	Sr	Condensate Recovery Line	St	Steam Trap
A	Filling Head	Sm ₁	Motive Medium Supply Pipe	Vi	Valve on Condensate Inlet Pipe
Pm	Motive Medium Supply Pressure	Sm ₂	Motive Medium Supply Tube	Vo	Valve on Condensate Outlet Pipe
		Se	Exhaust Pipe/Tube	Vm	Valve on Motive Medium Supply Pipe
Pb	Back Pressure	Dh	Condensate Receiver	Ve	Valve on Exhaust Pipe/Tube
Si	Condensate Inlet Pipe	Ki	Condensate Inlet Strainer	Vb	Blowdown Valve
So	Condensate Outlet Pipe	Km	Motive Medium Strainer	Pi	Equipment Pressure

Installation Procedure

Installation, inspection, maintenance, repairs, disassembly, adjustment and valve opening/closing should be carried out only by trained maintenance personnel.

(1) Pumped Medium:

- Fluids that can be discharged through the PowerTrap are limited to steam condensate and water. PowerTraps that have been specially constructed for other specific fluids are not limited by this restriction.

(2) Connecting the piping

- When connecting piping to the product, install appropriate piping support to prevent the piping load from being applied to the product. If piping load is applied, it may cause damage to threaded parts or leakage may occur from the sealing part.

(3) Motive Medium Supply Pipe [Sm₁] and Motive Medium Supply Tube [Sm₂]:

- The diameters of the motive medium supply pipe [Sm₁] and of the valve on the motive medium supply pipe [Vm] diameter should be at least 15 mm ($\frac{1}{2}$ in). If copper or stainless steel tubes are used for the connection from the motive medium supply tube [Sm₂] to the PowerTrap, make sure that the tube's inner diameter is at least 8 mm ($\frac{5}{16}$ in) but no more than 3 m (10 ft) in length. The inner diameter of the valve and tube fittings connecting to the PowerTrap should also be at least 8 mm ($\frac{5}{16}$ in).
- Install a strainer [Km] (at least 15 mm ($\frac{1}{2}$ in) and 40-mesh or finer) on the PowerTrap motive medium supply tube [Sm₂] as close to the PowerTrap as possible and install a union joint for maintenance, while allowing sufficient space for maintenance of the strainer. Strainers should be angled in the 3 or 9 o'clock positions for horizontal installations if installed on a horizontal piping.
- Only use steam, compressed air or nitrogen as the motive medium.
- The maximum motive medium supply pressure is 0.5 MPaG (75 psig, 5 barg).
- When the motive medium is steam, install a drip leg on the motive medium supply pipe [Sm₁], and a steam trap [St] on the drip leg. Proper discharge capacity may not be achieved if condensate accumulates in the motive medium supply pipe [Sm₁] or tube [Sm₂]. In addition, rust and scale can cause steam leakage, which results in the PowerTrap becoming inoperable.
- When steam or high temperature air is used as a motive medium, make sure to use steel pipe for the motive medium supply tube [Sm₂].

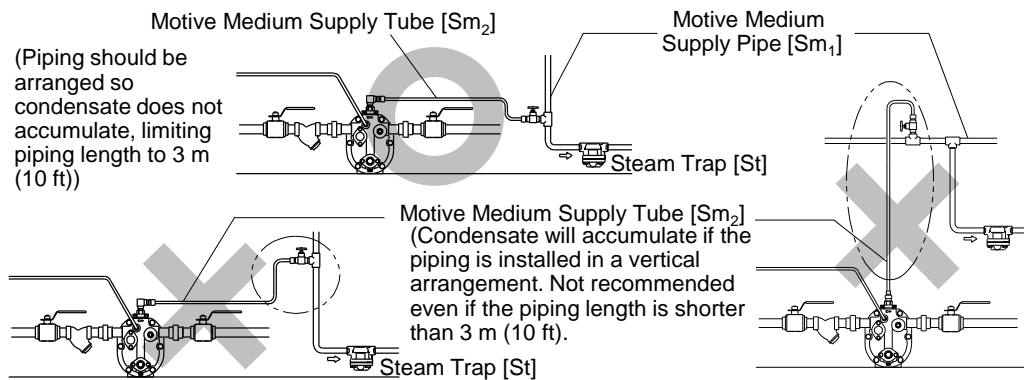

(4) Pressure Reducing Valve on the Motive Medium Supply Piping:

- When the motive medium pressure [P_m] is greater than 0.5 MPaG (75 psig, 5 barg), install a TLV pressure reducing valve in order to reduce the motive medium pressure to the PowerTrap. In order to prevent the pressure from rising at dead end shut off, be sure to install a relief valve between the pressure reducing valve and the PowerTrap.
- The set pressure of the pressure reducing valve should be equal to or greater than 0.05 MPa (7 psi, 0.5 bar) higher than the back pressure [P_b]. When the pumping capacity of the PowerTrap is insufficient for the set motive pressure, increase the set pressure even further. However, the set pressure must not exceed 0.5 MPaG.
- Install the pressure reducing valve as far away from the PowerTrap as possible.
 - When the motive medium pressure is less than 0.5 MPaG (72.5 psig, 5 barg): at least 3 m (10 ft)
 - When the motive medium pressure is 0.5 MPaG or greater (72.5 psig or greater, 5 barg or greater): at least 3 m + 1 m for every 0.1 MPaG (1 barg) over 0.5 MPaG (5 barg) (10 ft + 1 ft for every 4.5 psig over 72.5 psig)

(5) Exhaust Pipe/Tube

- The exhaust pipe/tube [Se] should be connected to the upper part of the condensate receiver [Dh]. The exhaust pipe/tube [Se] should be shorter than 3 m, and with an inner diameter of 8 mm or greater.
- Do not remove the exhaust plug installed on the product. This exhaust plug is needed to achieve proper operation. In the event the exhaust plug has been removed, wrap the thread part with 3 – 3.5 turns of sealing tape or apply sealing compound and tighten it to a torque of 30 N·m (22 lbf·ft).
- Connect the exhaust pipe/tube to the exhaust plug (inner diameter of 8 mm ($1/4$ in)). The pipe/tube can be connected using a commercially-available nipple, street elbow, ring joint, etc.
- When steam or high temperature air is used as a motive medium, make sure to use the steel pipe for the exhaust pipe/tube [Se].

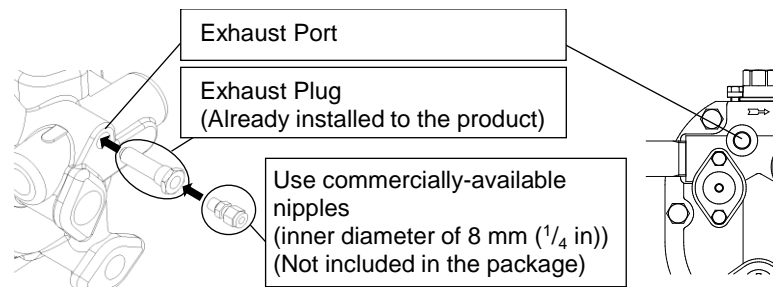

(6) Inlet and Outlet Piping

- Install a condensate inlet pipe [Si] to help condensate flow into the PowerTrap by gravity. The pipe thickness should be schedule 40 or less for proper operation.
- Install a condensate inlet strainer [Ki] (40-mesh or finer) on the PowerTrap pumped medium inlet pipe and install a union joint for maintenance.
- The condensate outlet pipe [So] diameter should be at least 25 mm (1 in).
- During pumping operation, the PowerTrap uses the motive medium supply pressure to push out the condensate from the body. The GP5C can discharge approximately 1.5 liters ($\frac{3}{8}$ US Gallons) of pumped medium for each discharge operation. The amount of time required for each discharge operation will be between 5 and 30 seconds, depending on the back pressure and the motive medium pressure. This means that the instantaneous flow through the pumped medium outlet pipe during the discharge operation is between 170 kg (370 lb) and 1 metric ton (2200 lb) per hour. Accordingly, flowmeters must not be installed on the condensate outlet pipe [So]. Install a steam flowmeter at the steam-using equipment inlet if necessary.

(7) Valves on the Various Pipes

- In order to ensure the proper discharge capacity, use full bore ball valves or gate valves on the condensate inlet [Vi] and outlet pipes [Vo].
- Be sure to install a blowdown valve [Vb]. A bellows sealed valve is recommended, due to the lack of leakage from the gland and easy flow rate adjustment.
- Install union or flanged joints between the valves and the PowerTrap to allow for easy maintenance.
- Be sure to provide the necessary maintenance space for PowerTrap disassembly and repair (see “Maintenance Space and Tolerance Angle for Installation”).

(8) Condensate Receiver [Dh] and Filling Head [A]

- Please refer to “Sizing the Condensate Receiver”.
The size and vent pipe aperture are determined by (a) the amount of flash steam in the in-flowing condensate (pumped medium) and (b) the amount of pumped medium held back while the PowerTrap is discharging.
If the receiver is small, the flow of flash steam may cause the condensate to flow out the vent pipe.
If the vent pipe size is small, the pressure in the receiver will rise, restricting the pumped medium inflow.
Be sure to select a receiver of the correct size.
- The filling head represents the distance from the bottom of the PowerTrap (from grade) to the bottom of the receiver (shown as [A] in the sketch in “Steam System Example”). Filling heads lower than the minimum filling head of 155 mm (6 in) must not be used.
- If venting flash steam to a high area, an overflow pipe must be installed to discharge

condensate to a safe area.

- An overflow pipe should be installed at the side of the receiver.



CAUTION

- Be sure to install a vent pipe and an overflow pipe. Failure to install an overflow pipe is dangerous, as condensate may spurt from the vent pipe and could result in burns and other injuries.
- Pipe the vent pipe and the overflow pipe to a safe place such as a pit.
- Piping size of the overflow pipe should be the same or larger than condensate inlet pipe.

Examples of Overflow Piping for Open Systems

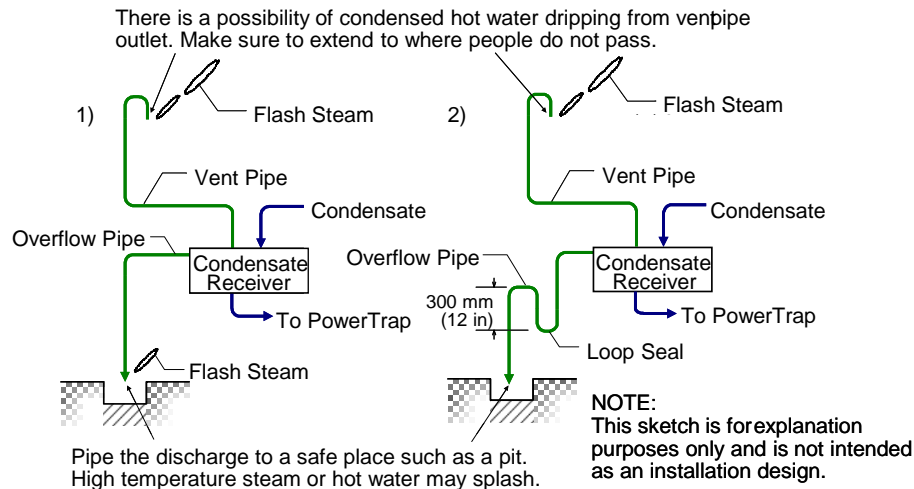

Explanations for overflow piping for open systems

1) If flash steam can be discharged from overflow pipe

Install overflow pipe and vent pipe separately.

2) If flash steam should not be released from overflow pipe (prevent flash steam release)

Install overflow pipe and vent pipe separately. For overflow pipe, install loop seal (approx. 300 mm (12 in)). Flash steam release from overflow pipe can be prevented since water always accumulates at loop seal. Piping size should be the same or larger than condensate inlet pipe.

NOTE: • There is a possibility of rust becoming clogged and/or corrosion since water always present in the loop seal; the possibility is greater if the piping diameter is too small (generally 25 mm (1 in) or smaller)

- Do not install loop seal on the vent pipe

Contact TLV if neither 1) nor 2) above can be installed.

Sizing the Condensate Receiver

When selecting the receiver for the GP5C, select from among the following steps:

- (1) Determine the amount of flash steam

(There may be a case that the flash steam hardly generates when the cold condensate is being pumped):

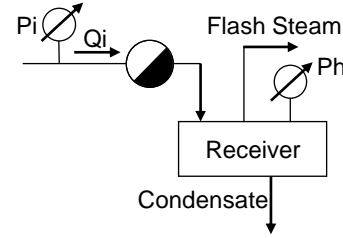

$$\text{Amount of flash steam } Fs = Q \times (hd' - hh')/r$$

Fs : amount of flash steam (kg/h) (lb/h)

Qi : amount of condensate (kg/h) (lb/h)

hd' : specific enthalpy (kJ/kg) (Btu/lb) of saturated condensate at condensate inlet set pressure (P_i)

hh' : specific enthalpy (kJ/kg) (Btu/lb) of saturated condensate at condensate receiver set pressure (P_h)

r : specific enthalpy (kJ/kg) (Btu/lb) vaporization (latent heat of steam) at condensate receiver set pressure (P_h)

- (2) Determine the vent pipe diameter according to the amount of flash steam in Vented Receiver Table - 1 shown on the next page.
- (3) Determine the overflow pipe diameter (D_{op} , refer to the figure below).

NOTE: The overflow pipe diameter should be at least as large as the condensate inlet pipe diameter (D_{cip} , refer to the figure below).

- (4) Determine the minimum condensate receiver diameter (D_{cr} , refer to the figure below) by selecting the largest value among those from (i), (ii), and (iii) based on a condensate receiver length of 1 m (3.3 ft).
- (i) is the overflow pipe diameter multiplied by 3 or more.
- (ii) is the minimum receiver diameter according to the amount of flash steam in Vented Receiver Table - 1 shown on the next page.
- (iii) is the minimum receiver diameter according to the amount of condensate in Vented Receiver Table - 2 shown on the next page.

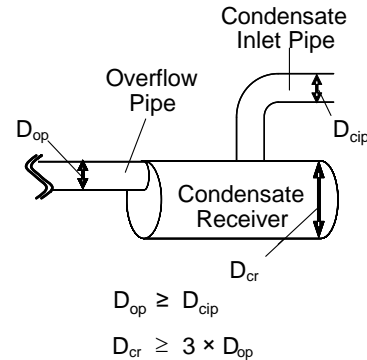

NOTE: Receiver length can be reduced by 50% when the motive pressure (P_m) divided by the back pressure (P_b) is "2" or greater. (When $P_m \div P_b \geq 2$)

Vented Receiver Table - 1

Flash Steam up to ~ kg/hour	Receiver Diameter mm (in) (Length: 1 m)	Vent Line Diameter mm (in)	Flash Steam up to ~ lb/hour	Receiver Diameter in (Length: 3.5 ft)	Vent Line Diameter in
25	80 (3)	25 (1)	50	3	1
50	100 (4)	50 (2)	100	4	2
75	125 (5)	50 (2)	150	5	2
100	150 (6)	80 (3)	200	6	3

Vented Receiver Table - 2

Amount of Condensate kg/hour	Receiver Diameter mm (in) (Length: 1 m)	Amount of Condensate lb/hour	Receiver Diameter in (Length: 3.5 ft)
50 or less	40 (1½)	100 or less	1½
100	40 (1½)	200	1½
200	40 (1½)	400	1½
300	50 (2)	600	2
400	65 (2½)	800	2½
500	80 (3)	1000	3

NOTE: When amount of flash steam and condensate are between two values in the table, select the larger value (one line below).

Maintenance Space and Tolerance Angle for Installation

Maintenance Space

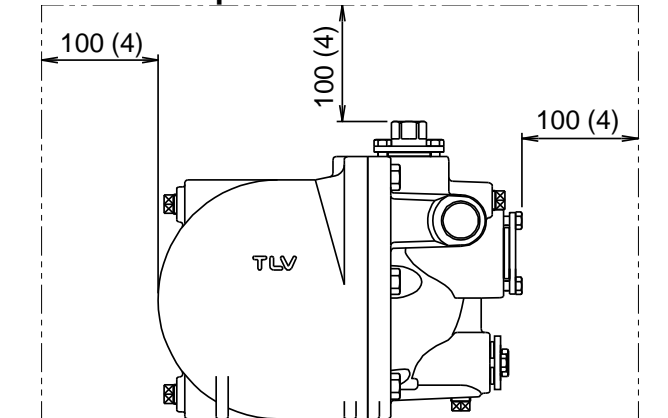

The maintenance space shown in the figure on the left should be provided to enable inspection and disassembly/repair of the GP5C

Unit: mm (in)

Tolerance Angle for Installation

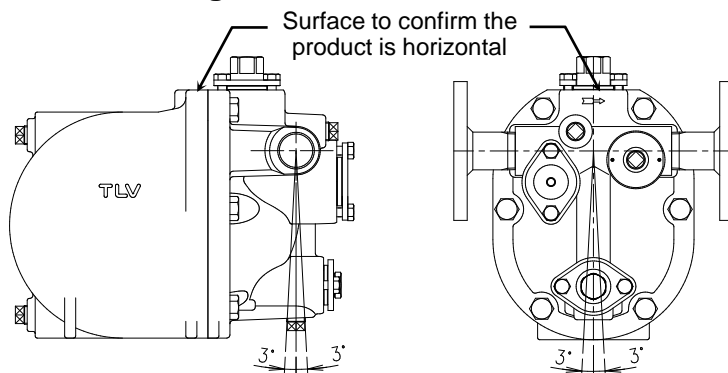

The product should be inclined no more than 3° front-to-back and left-to-right. Ensure the product is horizontal by checking the machined surface of the cover top.

Operation and Periodic Inspection

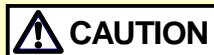

- After all piping work has been completed in accordance with the specific piping system designed when the decision to utilize the PowerTrap was made, check once again to make sure that all pipe connections have been tightened, gaskets have been inserted where needed and all parts are securely installed.
- At the start-up of operation, large quantities of condensate may flow, causing the PowerTrap to momentarily overload. Open the inlet valve gradually so that the condensate flows in slowly.



- Repairs or disassembly of the piping, adjustment and valve opening/closing should be carried out only by trained maintenance personnel.
- Before connecting piping or disassembling the product, close the inlet and outlet valves and make every effort to reduce the internal pressure to cool the product to room temperature.
- When disassembling connecting parts, remove pipes and bolts slowly to prevent condensate from suddenly flowing out in the event of residual pressure inside the product.



Install properly and **DO NOT** use this product outside the recommended operating pressure, temperature and other specification ranges. Improper use may result in such hazards as damage to the product or malfunctions which may lead to serious accidents. Local regulations may restrict the use of this product to below the conditions quoted.



When disassembling or removing the product, wait until the internal pressure equals atmospheric pressure and the surface of the product has cooled to room temperature. Disassembling or removing the product when it is hot or under pressure may lead to discharge of fluids, causing burns, other injuries or damage.



Be sure to use only the recommended components when repairing the product, and **NEVER** attempt to modify the product in any way. Failure to observe these precautions may result in damage to the product or burns or other injury due to malfunction or the discharge of fluids.

Installation, inspection, maintenance, repairs, disassembly, adjustment and valve opening/closing should be carried out only by trained maintenance personnel.

Operation

(1) Valve Operation

During the first operation after installation, or re-operation after a long shutdown, open the blowdown valve [Vb] (ensuring the area around the opening is safe) to eliminate rust and scale completely. Refer to the “Steam System Example” drawings in the “Installation” section to become familiar with the symbols used for the various valves.

If water hammer has occurred, immediately cease operation and close any valves that are operating.

- Slowly open the valve [Ve] on the exhaust pipe.
- Slowly open the valve [Vm] on the motive medium supply pipe. Make sure that there is no sound of flow from the exhaust pipe/tube [Se] or the condensate inlet pipe [Si].
- Slowly open the valve [Vo] on the condensate outlet pipe.
- Slowly open the valve [Vi] on the condensate inlet pipe.
- The PowerTrap is normal if it operates intermittently during pumping operation; first exhausting the motive medium to fill with pumped medium, then taking in motive

medium to force the condensate out.

The interval of operation will vary greatly depending on the amount of pumped medium inflow, the temperature, the motive medium pressure. (The interval of operation is considered the length of time between the start of one discharge cycle and the start of the next discharge cycle.)

The relation between the interval of operation T_c (seconds) and the amount of inflowing pumped medium (Q or Q_p) can be roughly determined using the following formula:

$$T_c = 5,350/Q \quad Q = 5,350/T_c \quad Q: \text{amount of inflowing pumped medium (kg/h)}$$

$$T_c = 11,888/Q_p \quad Q_p = 11,888/T_c \quad Q_p: \text{amount of inflowing pumped medium (lb/h)}$$

- (2) If an error such as a leak or water hammer occurs after beginning PowerTrap operation, shut off the valves immediately in the following order:
valve [Vm] on motive medium supply pipe → valve [Vi] on condensate inlet valve → valve [Vo] on condensate outlet pipe → valve [Ve] on exhaust pipe/tube
- (3) Whenever any type of malfunction is suspected in the PowerTrap, refer to the “Troubleshooting” section.

Periodic Inspection and Diagnosis

There are two types of periodic inspection: visual inspection and disassembly inspection.

(1) Visual Inspection

- As a general rule, this inspection should be performed at least once every 3 months.
- Check the following items:
 - a) There should be no leakage from the PowerTrap or from any of the connections.
 - b) The PowerTrap unit should be operating cyclically without continuous sound in the motive medium supply pipe or the exhaust pipe during the pumping operation (equipment side pressure \leq back pressure).
 - c) Condensate should not accumulate in the steam-using equipment, and the temperature of the equipment should not be abnormally low.
 - d) There should not be any abnormal noise (such as water hammer) from the pumped medium outlet pipe or the condensate recovery line when the PowerTrap operates.

(2) Disassembly Inspection

- Refer to the “Disassembly/Reassembly” section.
- As a general rule, this inspection should be performed at least once every 2 years.
- When inspecting the interior of the unit, check the following items:
 - a) Make sure the snap-action unit moves up and down smoothly as the float rises and falls.
 - b) Make sure the intake/exhaust valves move up and down smoothly.
 - c) Make sure the float is not damaged and is not filled with water.
 - d) Make sure all nuts and bolts are properly installed and fastened.
 - e) Check to make sure that there is no foreign matter sticking to the shafts and levers of any of the units, and make sure there is no abnormal wear.
- When reassembling, be sure to replace the body and cover gaskets with new gaskets if damaged.
- Also, replace any parts that are broken or show serious wear.
- If any parts require replacement, refer to the “Replacement Parts”.

Disassembly/Reassembly



WARNING

NEVER apply direct heat to the float. The float may explode due to increased internal pressure, causing accidents leading to serious injury or damage to property and equipment.



CAUTION

- Repairs or disassembly of the piping, adjustment and valve opening/closing should be carried out only by trained maintenance personnel.
- Before connecting piping or disassembling the product, close the inlet and outlet valves and make every effort to reduce the internal pressure to cool the product to room temperature.
- When disassembling connecting parts, remove pipes and bolts slowly to prevent condensate from suddenly flowing out in the event of residual pressure inside the product.



CAUTION

Use hoisting equipment for heavy objects (weighing approximately 20 kg (44 lb) or more). Failure to do so may result in back strain or other injury if the object should fall.



CAUTION

When disassembling or removing the product, wait until the internal pressure equals atmospheric pressure and the surface of the product has cooled to room temperature. Disassembling or removing the product when it is hot or under pressure may lead to discharge of fluids, causing burns, other injuries or damage.



CAUTION

Do not use excessive force when connecting threaded pipes to the product. Over-tightening may cause breakage leading to fluid discharge, which may cause burns or other injury.

Use the procedures on the following pages to remove components. Use the same procedures in reverse to reassemble. (Installation, inspection, maintenance, repairs, disassembly, adjustment and valve opening/closing should be carried out only by trained maintenance personnel.)

In cases where sufficient maintenance space has been provided for (see “Maintenance Space and Tolerance Angle for Installation”), maintenance can be carried out without disconnecting the inlet and outlet piping. Where there is insufficient maintenance space, first disconnect the inlet and outlet piping, and then move the unit to a spacious area in which maintenance can be carried out safely.



When reassembling:

- Also replace any gaskets, units or parts that are broken or show serious wear. If any parts require replacement, refer to “Replacement Parts”.
- When reassembling, coat threads and bolts with anti-seize. Tighten the body and cover bolts left and right in a uniform manner, being careful to avoid uneven tightening.
- If drawings or other special documentation were supplied for the product, any torque given there takes precedence over values shown in this Instruction Manual.



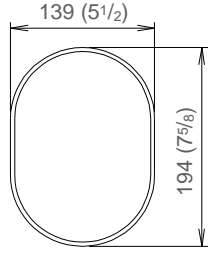

Replacement Parts

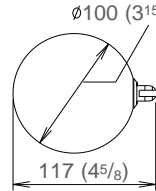
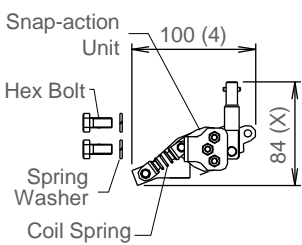
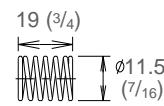
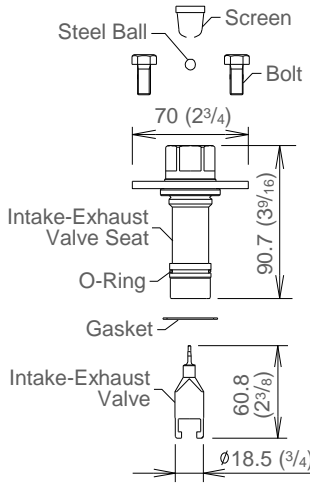
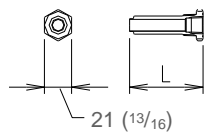
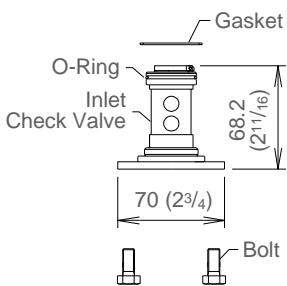
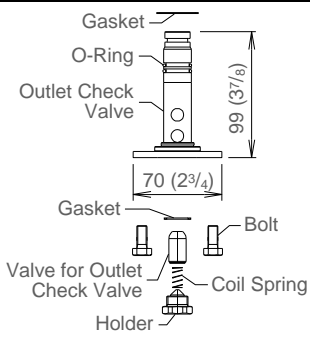
The following replacement parts are available from TLV. Parts are not available individually, only together in kits. (See “Configuration”)

Dimensions: mm (in)

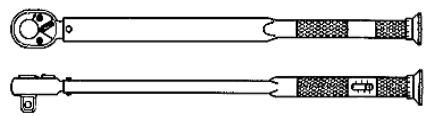
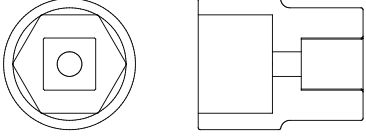
<p>1. Cover Gasket</p> 	<p>2. Seal Set</p>  <p>O-ring: 4 pcs. PTFE Gasket: 3 pcs. Metal Gasket: 1 pc.</p>	<p>3. Float</p>  <p>Weight: 0.27 kg (0.59 lb)</p>
<p>4. Snap-action Unit</p>  <p>Weight: 0.45 kg (0.99 lb)</p>	<p>5. Coil Spring (Snap-action Spring)</p> 	<p>6. Intake-Exhaust Valve Unit</p>  <p>Weight: 0.33 kg (0.73 lb)</p>
<p>7. Exhaust Plug</p>  <p>For Body Material FC250 (cast iron): L=51.5 (2) CF8M (cast stainless steel): L=56.5 (2 1/4)</p>	<p>8. Inlet Check Valve Unit</p>  <p>Weight: 0.33 kg (0.73 lb)</p>	<p>9. Outlet Check Valve Unit</p>  <p>Weight: 0.38 kg (0.84 lb)</p>

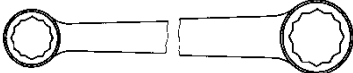
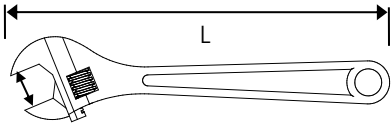
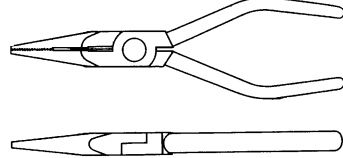
Recommended Tools List for Disassembly/Reassembly

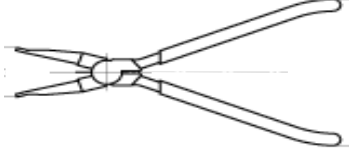
No.	Tool Name	Step Used	Tool
1	Torque Wrench (Ratchet) 0 – 100 N·m (0 – 73 lbf·ft)	1,2,3,4,5,6	
2	Sockets Distance across flats = S 13 mm (1/2 in) 19 mm (3/4 in) 22 mm (7/8 in)	3,4,6 2,5 4	
3	Extension Bar L = 150 mm (5 7/8 in)	5	
4	Offset Wrench 13 mm (1/2 in) 19 mm (3/4 in) 22 mm (7/8 in)	3,4,6 2 4	
5	Adjustable Wrench L=200 – 300 mm (8 – 12 in)	1, 6	
6	Needle-Nose Pliers	3	
7	Hex Key 2.5mm (3/32 in)	6	
8	Internal Snap Ring Pliers	4	

(1 N·m ≈ 10 kg·cm²)

NOTE: If drawings or other special documentation were supplied for the product, any torque given there takes precedence over values shown in this Instruction Manual.

1. Before Removing/Reattaching

Discharge the condensate from the body before removing parts.

Part	Disassembly	Reassembly
Plug	<ul style="list-style-type: none"> Using an adjustable wrench, slowly loosen the plug to release pressure and discharge fluid, take care to avoid being burned by fluid discharge. 	<ul style="list-style-type: none"> Wrap threads with 3 – 3.5 turns of sealing tape or apply sealing compound. Tighten to a torque of 30 N·m (22 lbf·ft).

(1 N·m ≈ 10 kg·cm²)

NOTE: If drawings or other special documentation were supplied for the product, any torque given there takes precedence over values shown in this Instruction Manual.

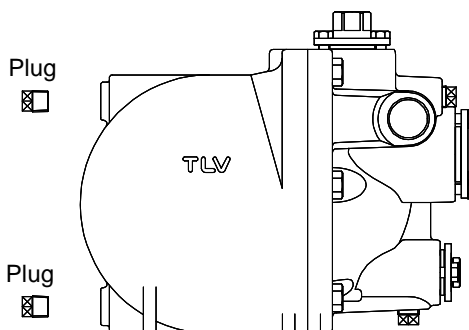

2. Removing/Reattaching the Body from/to the Cover

Prepare a new, replacement cover gasket before beginning this step.

Cover Bolts (M12 × 6 pcs)	<ul style="list-style-type: none"> Using a 19 mm (3/4 in) socket wrench, loosen each bolt slowly one turn in an alternating diagonal pattern. Once all bolts have been loosened, verify that there is no internal pressure before completely removing the bolts. 	<ul style="list-style-type: none"> Reverse steps in disassembly. Tighten to a torque of 60 N·m (44 lbf·ft).
Body	<ul style="list-style-type: none"> When removing the body, lift the float and the float lever slightly to avoid contact with the float. 	<ul style="list-style-type: none"> Reverse steps in disassembly while referring to the figure below.
Cover Gasket	<ul style="list-style-type: none"> The gasket may be damaged or destroyed upon disassembly, as it is inlaid in the body and may adhere to that groove; using a scratch-free scraper, carefully scrape the gasket from the body. 	<ul style="list-style-type: none"> Replace with a new gasket if damaged.

(1 N·m ≈ 10 kg·cm²)

NOTE: If drawings or other special documentation were supplied for the product, any torque given there takes precedence over values shown in this Instruction Manual.

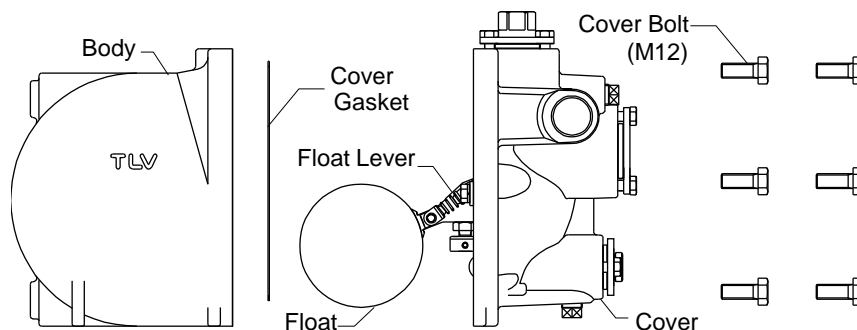

3. Removing/Reattaching the Snap-action Unit

Part	Disassembly	Reassembly
Hex Bolts (M8 × 2 pcs)/ Spring Washers (2 pcs)	<ul style="list-style-type: none"> Using a 13 mm (1/2 in) socket wrench, slowly loosen the two bolts that are holding the snap-action unit to the cover. 	<ul style="list-style-type: none"> Coat the bolt threads with anti-seize. Be sure to reinsert spring washers. Assemble the bolts and spring washers, then finger-tighten. Tighten to a torque of 35 N·m (26 lbf·ft)
Snap-action Unit	<ul style="list-style-type: none"> Support the snap-action unit with one hand while removing the loosened bolts and spring washers from the cover with the other. Remove snap-action unit from the cover holding it down. Be careful not to let any parts fall, including the coil spring or intake-exhaust valve. Do not tip the snap-action unit, as the intake-exhaust valve may fall off. When working with the snap-action unit, take care not to pinch fingers, etc. 	<ul style="list-style-type: none"> Reinsert the snap-action unit very carefully, inserting tips of intake-exhaust valve into the bottom of their respective valve seats, then continuing to insert all the way up into the valve seat as you reattach the snap-action unit. Align the snap-action unit bolt holes to the bolt holes in the cover.
Intake-Exhaust Valve	<ul style="list-style-type: none"> Remove the intake-exhaust valve by rotating it 90°. Remove the coil spring. 	<ul style="list-style-type: none"> Reattach the intake-exhaust valve by rotating it 90°. Reattach the coil spring.
Float/ Float Pin/ Washer/ R-pin	<ul style="list-style-type: none"> Remove the float and the float holder by removing the float pin and pulling out the R-pin. Be careful not to let the float fall. Do not drop the float or lose the washers. Replace the float if it is filled with water or cracked. 	<ul style="list-style-type: none"> Reattach the float and the spring holder by inserting the float pin and the R-pin. The coil spring will be inserted later.

(1 N·m ≈ 10 kg·cm²)

NOTE: If drawings or other special documentation were supplied for the product, any torque given there takes precedence over values shown in this Instruction Manual.

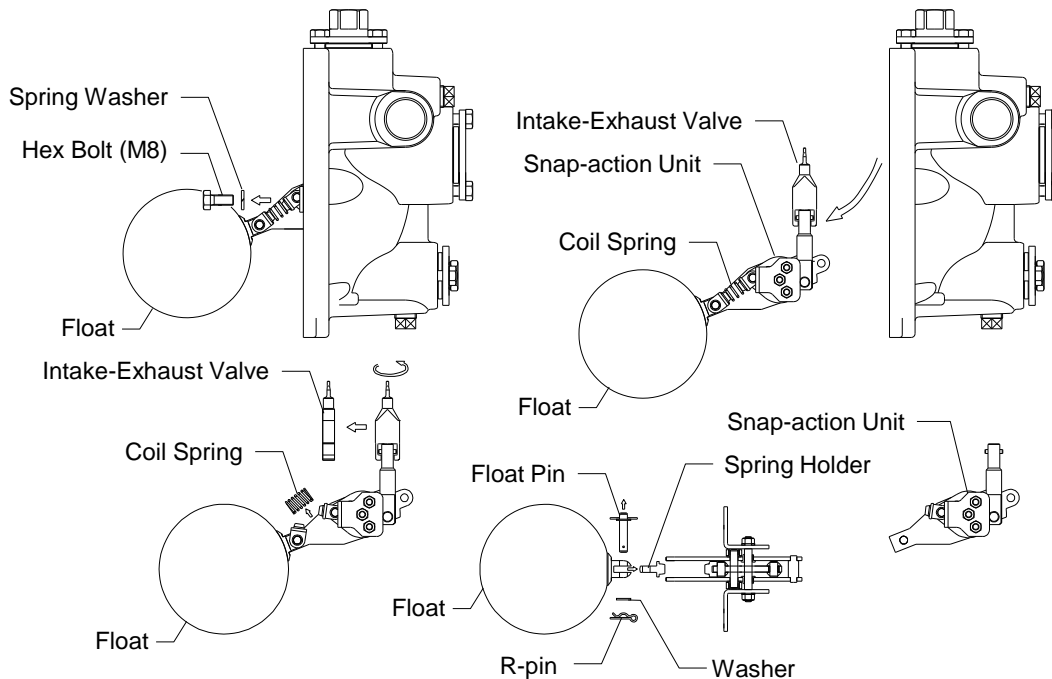

4. Removing/Reattaching Each Unit

Part	Disassembly	Reassembly
Intake-Exhaust Valve Seat/ Bolt (M8 × 2 pcs)/ Snap Ring/ Screen/ Steel Ball/ O-Ring/ Gasket	<ul style="list-style-type: none"> Remove bolts with a 13 mm (1/2 in) socket wrench. Remove the intake-exhaust valve seat from the cover. Be careful not to let the steel ball and the screen fall when removing the snap ring. Remove the O-ring. Clean the sealing surfaces. 	<ul style="list-style-type: none"> Replace with a new O-ring Replace with a new gasket if damaged. Coat O-ring with heatproof grease and be sure to clean the mounting surface in the cover. Tighten to a torque of 10 N·m (7 lbf·ft).
Bolt (M8 × 2 pcs)/ Inlet Check Valve/ O-Ring/ Gasket	<ul style="list-style-type: none"> Remove bolts with a 13 mm (1/2 in) socket wrench. Remove the inlet check valve from the cover. If difficult, screw the bolt into the center of the inlet check valve and use it to remove the inlet check valve. Remove the O-ring. Clean the sealing surfaces. 	<ul style="list-style-type: none"> Replace with a new O-ring Replace with a new gasket if damaged. Coat O-ring with heatproof grease and be sure to clean the mounting surface in the cover. In order to orient the hinge of the valve upwards, be sure the indentation is pointed upwards. Tighten to a torque of 10 N·m (7 lbf·ft).
Holder/ Gasket/ Coil Spring/ Valve for Outlet Check Valve	<ul style="list-style-type: none"> Take out the holder, gasket, coil spring and the valve for outlet check valve before removing the outlet check valve. Remove the spring holder with a 22 mm (7/8 in) socket wrench. Be careful not to let the coil spring and the gasket fall. 	<ul style="list-style-type: none"> Be sure to clean the inside of the outlet check valve. Replace with a new gasket if damaged. Tighten to a torque of 60 N·m (44 lbf·ft).
Bolt (M8 × 2 pcs)/ Outlet Check Valve/ O-Ring (2 pcs)/ Gasket	<ul style="list-style-type: none"> Remove bolts with a 13 mm (1/2 in) socket wrench. Remove the outlet check valve from the cover. Remove the O-ring and gasket. 	<ul style="list-style-type: none"> Replace with a new O-ring Replace with a new gasket if damaged. Coat O-ring with heatproof grease and be sure to clean the mounting surface in the cover. In order to assure proper flow direction, be sure the indentation is pointed upwards. Tighten to a torque of 10 N·m (7 lbf·ft).

(1 N·m ≈ 10 kg·cm²)

NOTE: If drawings or other special documentation were supplied for the product, any torque given there takes precedence over values shown in this Instruction Manual.

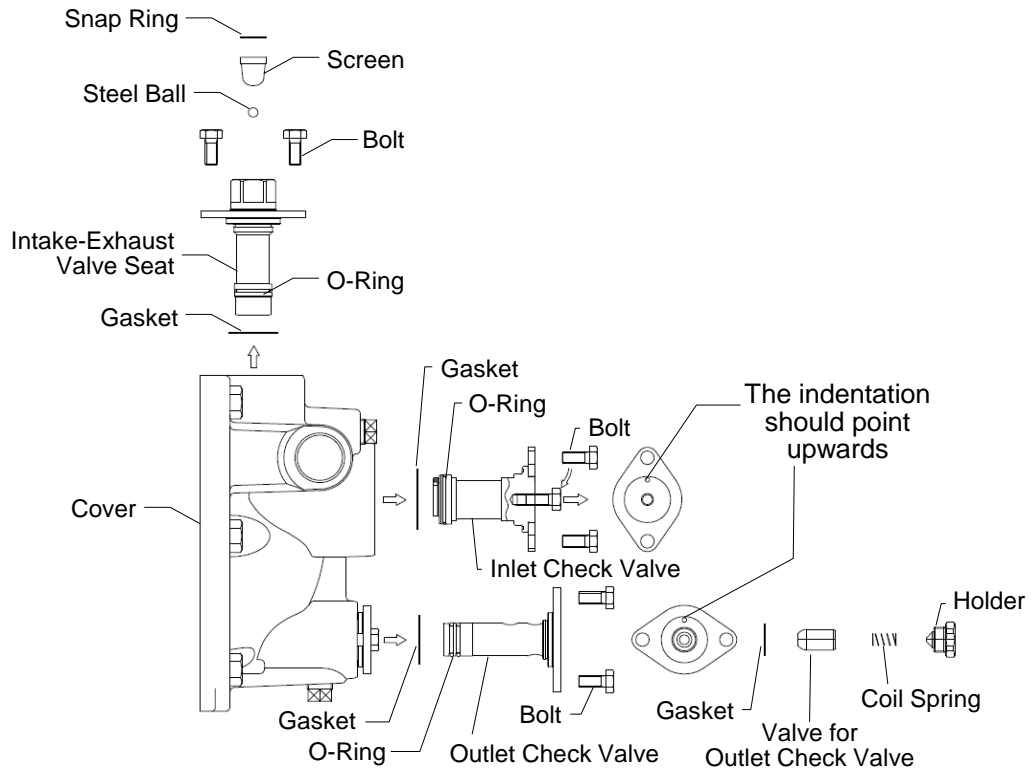

Troubleshooting



WARNING

NEVER apply direct heat to the float. The float may explode due to increased internal pressure, causing accidents leading to serious injury or damage to property and equipment.



CAUTION

- Repairs or disassembly of the piping, adjustment and valve opening/closing should be carried out only by trained maintenance personnel.
- Before connecting piping or disassembling the product, close the inlet and outlet valves and make every effort to reduce the internal pressure to cool the product to room temperature.
- When disassembling connecting parts, remove pipes and bolts slowly to prevent condensate from suddenly flowing out in the event of residual pressure inside the product.



CAUTION

When disassembling or removing the product, wait until the internal pressure equals atmospheric pressure and the surface of the product has cooled to room temperature. Disassembling or removing the product when it is hot or under pressure may lead to discharge of fluids, causing burns, other injuries or damage.

When the desired performance is not attained with the system, in many cases it is due to the following:

- (1) Loose chips from pipe cutting and tapping and/or welding scraps or sealant get caught in the intake valve (motive medium) or check valve and prevent them from closing/operating properly.
- (2) Changes in the amount of condensate inflow, motive pressure or back pressure that are in excess of the original design.

Since successful operation of the PowerTrap system depends on the proper design and installation of the system, investigate the entire system to locate the source of problems when they occur. When no source can be identified, inspect the PowerTrap and take whatever action is necessary.

Determining the Problem from the Symptoms

Use the “Types of Failure and their Causes” table on the following page to determine the cause of the problem from the type of abnormality that has occurred. Apply the corrective measures listed in the “Causes and Corrective Measures” table.

Types of Failure and their Causes

Detailed explanations of the meanings of the numbers listed in the “Types of Failure” column are found in the “Causes and Corrective Measures” table.

Pump is in the correct operating condition when $P_i \leq P_b$ (equipment pressure P_i is equal to or lower than back pressure P_b).

	Has the PowerTrap operated at least once?	Has pumped medium collected in the PowerTrap?	Is there a continuous flowing sound from the motive medium supply pipe?	Is there a continuous flowing sound from the exhaust pipe?	Types of Failure (Category A – G) and Corrective Measures (Causes 1 – 4)								
					A	B	C	D	E	F	G		
Does not pump	NO	NO	NO	NO	1,2,3			1			3		
		YES	YES	YES					1				
	YES	NO	NO	NO	NO	1	1,2,3	1,2,3	4				
		YES	YES	YES	NO						1		
	NO	NO	NO	NO	NO					2	1		
		YES	YES	YES	NO								1,2
	YES	NO	NO	NO	NO					1	1,2		
		YES	YES	YES	NO						3		
	NO	NO	NO	NO	NO						1		
		YES	YES	YES	NO					1	3,4		
	YES	NO	NO	NO	NO							1	
		YES	YES	YES	YES								1

Causes and Corrective Measures

Category	Cause	Procedure
A. A valve on the pipeline is closed	<ol style="list-style-type: none"> 1. The valve on the motive medium supply pipe is closed 2. The valve on the exhaust pipe is closed 3. The valve on the condensate inlet pipe is closed 4. The valve on the condensate outlet pipe is closed 	<ul style="list-style-type: none"> • Slowly open the valve, using the proper procedure <p>Check valves around the PowerTrap. If they are open, check other valves on pipes connected to the PowerTrap, as the valve may have been left closed due to other repairs or maintenance</p>
B. The strainer is clogged	<ol style="list-style-type: none"> 1. The strainer on the motive medium supply pipe is clogged 2. The strainer on the condensate inlet pipe is clogged 	<ul style="list-style-type: none"> • Clean the strainer <p>Please note that a large amount of rust and/or scale may accumulate during initial startup of seasonal-use equipment.</p>
C. Faulty motive medium pressure, back pressure or pressure inside equipment	1. The motive medium supply pressure is less than the back pressure	<ul style="list-style-type: none"> • When the motive medium pressure is decreasing, adjust the pressure reducing valve on the supply pipe or connect to a separate high-pressure line • If the back pressure has increased, check to see if a steam trap connected to the condensate recovery line is blowing (see "Steam System Example") and check for any valves that have been left closed on the condensate recovery line • The motive medium pressure should be equal to or greater than 0.05 MPa (7 psi, 0.5 bar) higher than the back pressure.
	2. Insufficient motive medium	<ul style="list-style-type: none"> • If the motive medium supply pipe is too small, change to a larger size pipe; the pipe should be at least 15 mm (½ in) near the PowerTrap • In case a tube is used for connecting the motive medium pipe to the PowerTrap, the tube's inner diameter (including valves and fittings in between) should be at least 8 mm (⁵/₁₆ in) and within 3 m (10 ft) length.
	3. Pressure inside equipment or motive medium supply pressure exceeds maximum operating pressure of PowerTrap	<ul style="list-style-type: none"> • When the pressure inside the equipment or the motive medium supply pressure exceeds the maximum operating pressure of the PowerTrap, the intake-exhaust valve stays closed, which results in inability to discharge condensate. Reduce the pressure to lower than the maximum operating pressure • Check the reason that the pressure inside equipment or motive medium supply pressure has increased, and take any necessary measures to fix it

Category	Cause	Procedure
D. Faulty piping	<ol style="list-style-type: none"> 1. The exhaust is abnormal 2. The condensate inlet pipe is too small 3. Not enough pumped medium is flowing through the valve on condensate inlet pipe 	<ul style="list-style-type: none"> • Air-locking or vapor-locking has occurred. The exhaust pipe is connected to the receiver, but the pumped medium may not be exchanged for the medium inside the PowerTrap for the following reasons: <ol style="list-style-type: none"> 1. There are places that accumulate condensate such as a U-shaped pipe between the exhaust port and the receiver 2. The inner diameter of the exhaust pipe or tube is less than 8 mm (⁵/₁₆ in) 3. The exhaust plug is not installed properly. <p>Correct the piping or exhaust plug installation. For all corrections, refer to “Installation Procedure”.</p> • Normal pumped medium flow may not be obtained if the pumped medium inlet pipe is too small or the valve on the pumped medium inlet pipe is a needle valve or one with a small Cv value. • The pipe and stop valve size must be increased to the design pipe size, and a full bore ball valve or gate valve must be used
E. Faulty PowerTrap	<ol style="list-style-type: none"> 1. Dirt or scale is caught in the intake-exhaust valve or the valve is worn 2. Dirt or scale is caught in the intake-exhaust valve seat or the valve seat is worn 3. The snap-action unit is obstructed by dirt or scale or its operation is otherwise faulty 4. The float is broken or filled with water 	<ul style="list-style-type: none"> • If the PowerTrap does not operate for long periods of time, in spite of the fact that pumped medium has collected in the receiver or equipment, if there is no sound at all of the operating medium flowing in the motive medium supply pipe/tube and the exhaust pipe/tube, it is possible that the PowerTrap is faulty. Note, however, that this phenomenon will also occur when the motive medium pressure is equal to or less than the back pressure • If the PowerTrap does not operate for long periods of time and the sound of the operating medium can be heard continuously in the motive medium supply pipe/tube, the PowerTrap is faulty Disassemble the PowerTrap, and inspect the following items: <ol style="list-style-type: none"> 1. Raise and lower the float and check to make sure the snap-action unit operates properly 2. Check the intake-exhaust valve and valve seat to make sure there is no dirt or scale caught or any other abnormality 3. Check other possible factors that might hinder operation <p>After performing the above inspection, repair any defects discovered or replace the PowerTrap</p>
F. Faulty check valve	<ol style="list-style-type: none"> 1. Dirt or scale is caught in the inlet check valve or the valve is worn or getting hung up 2. Dirt or scale is caught in the outlet check valve or the valve is worn or getting hung up 	<ul style="list-style-type: none"> • The operating medium that has been supplied is leaking from the inlet check valve, preventing the pressure inside the body from increasing; as a result, the pumped medium is not discharged Disassembly and inspection is required • The discharged pumped medium has flowed back into the PowerTrap, causing the interval at which the unit operates to grow shorter and reducing its discharge capacity Disassembly and inspection is required
G. Degradation or damage of gasket and O-ring	<ol style="list-style-type: none"> 1. Damage when assembling 2. Aging degradation 	<ul style="list-style-type: none"> • When condensate or steam leaks from the PowerTrap, tighten the bolts with the proper torque or replace the gasket with a new one. • When steam leaks into the equipment (to the pumped medium inlet side) or outlet piping, check the O-ring.

TLV EXPRESS LIMITED WARRANTY

Subject to the limitations set forth below, TLV Corporation, a North Carolina corporation (“**TLV**”) warrants that products which are sold by it, TLV CO., LTD., a Japanese corporation (“**TLVJ**”) or TLV International, Inc., a Japanese corporation (“**TII**”), (hereinafter the “**Products**”) are designed and manufactured by TLVJ, conform to the specifications published by TLV for the corresponding part numbers (the “**Specifications**”) and are free from defective workmanship and materials. With regard to products or components manufactured by unrelated third parties (the “**Components**”), TLV provides no warranty other than the warranty from the third party manufacturer(s), if any.

Exceptions to Warranty

This warranty does not cover defects or failures caused by:

1. improper shipping, installation, use, handling, etc., by other than TLV or service representatives authorized by TLV; or
2. dirt, scale or rust, etc.; or
3. improper disassembly and reassembly, or inadequate inspection and maintenance by other than TLV or service representatives authorized by TLV; or
4. disasters or forces of nature or Acts of God; or
5. abuse, abnormal use, accidents or any other cause beyond the control of TLV; or
6. improper storage, maintenance or repair; or
7. operation of the Products not in accordance with instructions issued with the Products or with accepted industry practices; or
8. use for a purpose or in a manner for which the Products were not intended; or
9. use of the Products in a manner inconsistent with the Specifications; or
10. use of the Products with Hazardous Fluids (fluids other than steam, air, water, nitrogen, carbon dioxide and inert gases (helium, neon, argon, krypton, xenon and radon)); or
11. failure to follow the instructions contained in the TLV Instruction Manual for the Product.

Duration of Warranty

This warranty is effective for a period of the earlier of: (i) three (3) years after delivery of Products to the first end user in the case of sealed SST-Series Products for use in steam pressure service up to 650 psig; (ii) two (2) years after delivery of Products to the first end user in the case of PowerTrap® units; or (iii) one (1) year after delivery of Products to the first end user in the case of all other Products. Notwithstanding the foregoing, asserting a claim under this warranty must be brought by the earlier of one of the foregoing periods, as applicable, or within five (5) years after the date of delivery to the initial buyer if not sold initially to the first end user.

ANY IMPLIED WARRANTIES NOT NEGATED HEREBY WHICH MAY ARISE BY OPERATION OF LAW, INCLUDING THE IMPLIED WARRANTIES OF MERCHANTABILITY AND FITNESS FOR A PARTICULAR PURPOSE AND ANY EXPRESS WARRANTIES NOT NEGATED HEREBY, ARE GIVEN SOLELY TO THE INITIAL BUYER AND ARE LIMITED IN DURATION TO ONE (1) YEAR FROM THE DATE OF SHIPMENT BY TLV.

Exclusive Remedy

THE EXCLUSIVE REMEDY UNDER THIS WARRANTY, UNDER ANY EXPRESS WARRANTY OR UNDER ANY IMPLIED WARRANTIES NOT NEGATED HEREBY (INCLUDING THE IMPLIED WARRANTIES OF MERCHANTABILITY AND FITNESS FOR A PARTICULAR PURPOSE), IS **REPLACEMENT**; PROVIDED: (a) THE CLAIMED DEFECT IS REPORTED TO TLV IN WRITING WITHIN THE APPLICABLE WARRANTY PERIOD, INCLUDING A DETAILED WRITTEN DESCRIPTION OF THE CLAIMED DEFECT AND HOW AND WHEN THE CLAIMED DEFECTIVE PRODUCT WAS USED; AND (b) THE CLAIMED DEFECTIVE PRODUCT AND A COPY OF THE PURCHASE INVOICE IS RETURNED TO TLV, FREIGHT AND

TRANSPORTATION COSTS PREPAID, UNDER A RETURN MATERIAL AUTHORIZATION AND TRACKING NUMBER ISSUED BY TLV. ALL LABOR COSTS, SHIPPING COSTS, AND TRANSPORTATION COSTS ASSOCIATED WITH THE RETURN OR REPLACEMENT OF THE CLAIMED DEFECTIVE PRODUCT ARE SOLELY THE RESPONSIBILITY OF BUYER OR THE FIRST END USER. TLV RESERVES THE RIGHT TO INSPECT ON THE FIRST END USER'S SITE ANY PRODUCTS CLAIMED TO BE DEFECTIVE BEFORE ISSUING A RETURN MATERIAL AUTHORIZATION. SHOULD SUCH INSPECTION REVEAL, IN TLV'S REASONABLE DISCRETION, THAT THE CLAIMED DEFECT IS NOT COVERED BY THIS WARRANTY, THE PARTY ASSERTING THIS WARRANTY SHALL PAY TLV FOR THE TIME AND EXPENSES RELATED TO SUCH ON-SITE INSPECTION.

Exclusion of Consequential and Incidental Damages

IT IS SPECIFICALLY ACKNOWLEDGED THAT THIS WARRANTY, ANY OTHER EXPRESS WARRANTY NOT NEGATED HEREBY, AND ANY IMPLIED WARRANTY NOT NEGATED HEREBY, INCLUDING THE IMPLIED WARRANTIES OF MERCHANTABILITY AND FITNESS FOR A PARTICULAR PURPOSE, DO NOT COVER, AND NEITHER TLV, TII NOR TLVJ WILL IN ANY EVENT BE LIABLE FOR, INCIDENTAL OR CONSEQUENTIAL DAMAGES, INCLUDING, BUT NOT LIMITED TO LOST PROFITS, THE COST OF DISASSEMBLY AND SHIPMENT OF THE DEFECTIVE PRODUCT, INJURY TO OTHER PROPERTY, DAMAGE TO BUYER'S OR THE FIRST END USER'S PRODUCT, DAMAGE TO BUYER'S OR THE FIRST END USER'S PROCESSES, LOSS OF USE, OR OTHER COMMERCIAL LOSSES. WHERE, DUE TO OPERATION OF LAW, CONSEQUENTIAL AND INCIDENTAL DAMAGES UNDER THIS WARRANTY, UNDER ANY OTHER EXPRESS WARRANTY NOT NEGATED HEREBY OR UNDER ANY IMPLIED WARRANTY NOT NEGATED HEREBY (INCLUDING THE IMPLIED WARRANTIES OF MERCHANTABILITY AND FITNESS FOR A PARTICULAR PURPOSE) CANNOT BE EXCLUDED, SUCH DAMAGES ARE EXPRESSLY LIMITED IN AMOUNT TO THE PURCHASE PRICE OF THE DEFECTIVE PRODUCT. THIS EXCLUSION OF CONSEQUENTIAL AND INCIDENTAL DAMAGES, AND THE PROVISION OF THIS WARRANTY LIMITING REMEDIES HEREUNDER TO REPLACEMENT, ARE INDEPENDENT PROVISIONS, AND ANY DETERMINATION THAT THE LIMITATION OF REMEDIES FAILS OF ITS ESSENTIAL PURPOSE OR ANY OTHER DETERMINATION THAT EITHER OF THE ABOVE REMEDIES IS UNENFORCEABLE, SHALL NOT BE CONSTRUED TO MAKE THE OTHER PROVISIONS UNENFORCEABLE.

Exclusion of Other Warranties

THIS WARRANTY IS IN LIEU OF ALL OTHER WARRANTIES, EXPRESS OR IMPLIED, AND ALL OTHER WARRANTIES, INCLUDING BUT NOT LIMITED TO THE IMPLIED WARRANTIES OF MERCHANTABILITY AND FITNESS FOR A PARTICULAR PURPOSE, ARE EXPRESSLY DISCLAIMED.

Severability

Any provision of this warranty which is invalid, prohibited or unenforceable in any jurisdiction shall, as to such jurisdiction, be ineffective to the extent of such invalidity, prohibition or unenforceability without invalidating the remaining provisions hereof, and any such invalidity, prohibition or unenforceability in any such jurisdiction shall not invalidate or render unenforceable such provision in any other jurisdiction.

TLV CORPORATION

13901 South Lakes Drive, Charlotte, NC 28273-6790, U.S.A.

Tel: [1]-704-597-9070 Fax: [1]-704-583-1610