



Instruction Manual

Electro-Pneumatic Control Valve with Built-in Separator and Steam Trap

CV-COS-20/CV-COS-20D

(for Valve Unit)

Contents

Introduction	1
Safety Considerations	2
Specifications	4
Configuration	5
Installation	9
Maintenance	13
Disassembly/Reassembly	14
Troubleshooting.....	25
TLV EXPRESS LIMITED WARRANTY	26
Service	28
Options	29

Introduction

Thank you for purchasing the TLV electro-pneumatic control valve with built-in separator and steam trap CV-COS-20/CV-COS-20D.

This product has been thoroughly inspected before being shipped from the factory. When the product is delivered, before doing anything else, check the specifications and external appearance to make sure nothing is out of the ordinary. Also be sure to read this manual carefully before use and follow the instructions to be sure of using the product properly.

If detailed instructions for special order specifications or options not contained in this manual are required, please contact TLV for full details.

The TLV electro-pneumatic control valve with built-in separator and steam trap is a revolutionary product that combines a digital positioner, a diaphragm-type actuator, a separator and a steam trap. Steam-using equipment can achieve its intended efficiency only if the steam being used is very dry. Using steam in which matter such as condensate, scale or types of grease is entrained can not only result in problems with the steam-using equipment and in lowered productivity, but can also lead to shortened service life for and malfunction of the control valve. The CV-COS-20/CV-COS-20D are control valves that offer a solution for these problems by supplying high-quality steam to the process and offering maximum productivity.

This instruction manual is intended for use with the model(s) listed on the front cover. It is needed not only for installation, but also for subsequent maintenance, disassembly/reassembly and troubleshooting. Please keep it in a safe place for future reference.

For details of the actuator and the electro-pneumatic digital positioner, refer to the respective instruction manuals issued by the manufacturer.

Safety Considerations

- Read this section carefully before use and be sure to follow the instructions.
- Installation, inspection, maintenance, repairs, disassembly, adjustment and valve opening/closing should be carried out only by trained maintenance personnel.
- The precautions listed in this manual are designed to ensure safety and prevent equipment damage and personal injury. For situations that may occur as a result of erroneous handling, three different types of cautionary items are used to indicate the degree of urgency and the scale of potential damage and danger: DANGER, WARNING and CAUTION.
- The three types of cautionary items above are very important for safety: be sure to observe all of them as they relate to installation, use, maintenance and repair. Furthermore, TLV accepts no responsibility for any accidents or damage occurring as a result of failure to observe these precautions.

Symbols

	Indicates a DANGER, WARNING or CAUTION item.
	Indicates an urgent situation which poses a threat of death or serious injury
	Indicates that there is a potential threat of death or serious injury
	Indicates that there is a possibility of injury or equipment / product damage
	<p>NEVER apply direct heat to the float. The float may explode due to increased internal pressure, causing accidents leading to serious injury or damage to property and equipment.</p>
	<p>Install properly and DO NOT use this product outside the recommended operating pressure, temperature and other specification ranges. Improper use may result in such hazards as damage to the product or malfunctions that may lead to serious accidents. Local regulations may restrict the use of this product to below the conditions quoted.</p> <p>DO NOT use the product in excess of the maximum operating pressure differential. Such use could make discharge through the steam trap impossible (blocked).</p> <p>Use hoisting equipment for heavy objects (weighing approximately 20 kg (44 lb) or more). Failure to do so may result in back strain or other injury if the object should fall.</p> <p>DO NOT use only the actuator eye bolt when hoisting or lifting the assembled product. Failure to observe this precaution may lead to product damage.</p>

Continued on the next page

 CAUTION	<p>Take measures to prevent people from coming into direct contact with product outlets.</p>
	<p>Failure to do so may result in burns or other injury from the discharge of fluids.</p>
	<p>When disassembling or removing the product, wait until the internal pressure equals atmospheric pressure and the surface of the product has cooled to room temperature.</p>
	<p>Disassembling or removing the product when it is hot or under pressure may lead to discharge of fluids, causing burns, other injuries or damage.</p>
	<p>Be sure to use only the recommended components when repairing the product, and NEVER attempt to modify the product in any way.</p>
	<p>Failure to observe these precautions may result in damage to the product and burns or other injury due to malfunction or the discharge of fluids.</p>
	<p>Do not use excessive force when connecting threaded pipes to the product.</p>
	<p>Over-tightening may cause breakage leading to fluid discharge, which may cause burns or other injury.</p>
	<p>Use only under conditions in which no freeze-up will occur.</p>
<p>Freezing may damage the product, leading to fluid discharge, which may cause burns or other injury.</p>	
<p>Use only under conditions in which no water hammer will occur.</p>	
<p>The impact of water hammer may damage the product, leading to fluid discharge, which may cause burns or other injury.</p>	
<p>Make sure the power supply is OFF before carrying out work on the wiring or inspections involving disassembly.</p>	
<p>If such work is carried out with the power on, there is a danger that equipment may malfunction or electric shock may occur, leading to injury or other accidents.</p>	
<p>Make sure that wiring work requiring a special license is carried out by qualified personnel.</p>	
<p>If carried out by unqualified personnel, overheating or short circuits leading to injury, fires, damage or other accidents may occur.</p>	
<p>When using this product, NEVER stand close to, or leave tools anywhere near, moving parts, such as the shaft.</p>	
<p>Contact with moving parts or objects becoming caught in moving parts could lead to injury or damage or other accidents.</p>	

Specifications



Install properly and **DO NOT** use this product outside the recommended operating pressure, temperature and other specification ranges. Improper use may result in such hazards as damage to the product or malfunctions which may lead to serious accidents. Local regulations may restrict the use of this product to below the conditions quoted.



DO NOT use the product in excess of the maximum operating pressure differential; such use could make discharge impossible (blocked).



Use only under conditions in which no freeze-up will occur. Freezing may damage the product, leading to fluid discharge, which may cause burns or other injury.

Refer to the product nameplate for detailed specifications.

Valve Section

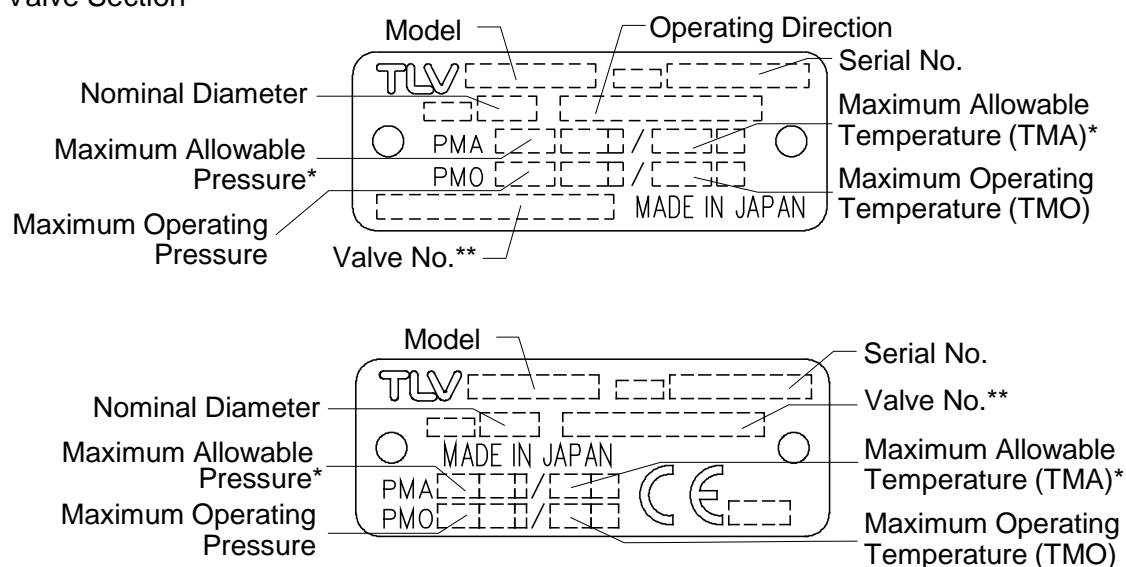

Actuator Section

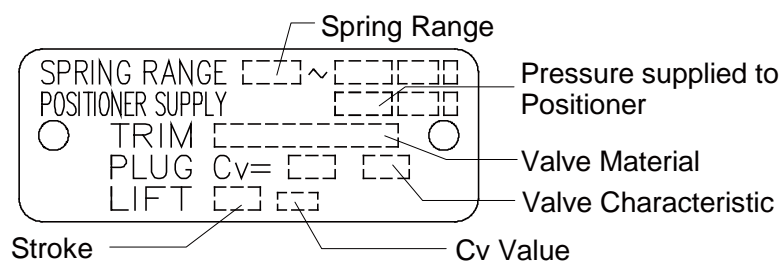

*Maximum allowable pressure (PMA) and maximum allowable temperature (TMA) are PRESSURE SHELL DESIGN CONDITIONS, **NOT** OPERATING CONDITIONS.

**Valve No. is displayed for products with options. This item is omitted from the nameplate when there are no options.

Configuration

CV-COS-20

Sizes 15 to 50 mm (1/2 to 2 in)

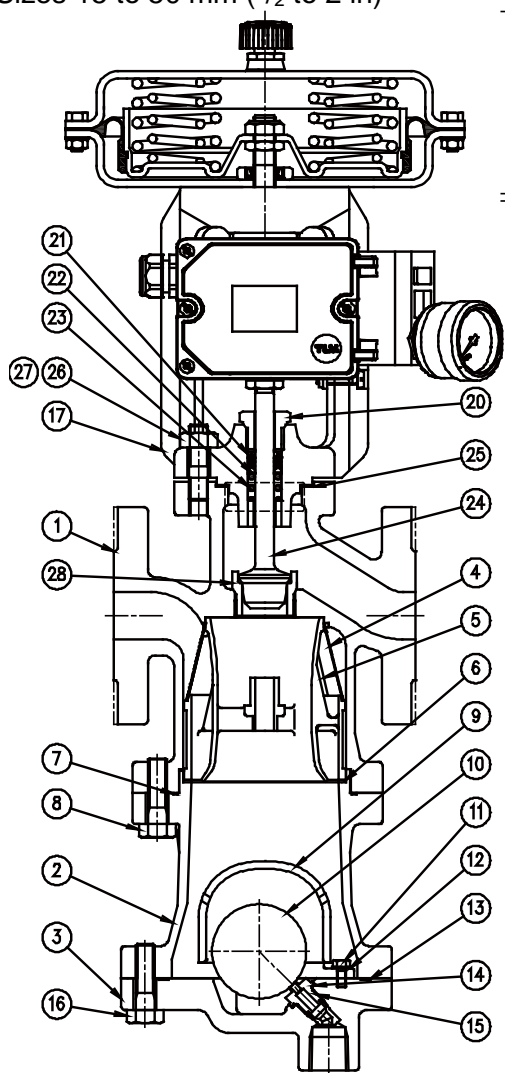

Eye Bolt
Actuator area
700 cm² (1.08 in²) only

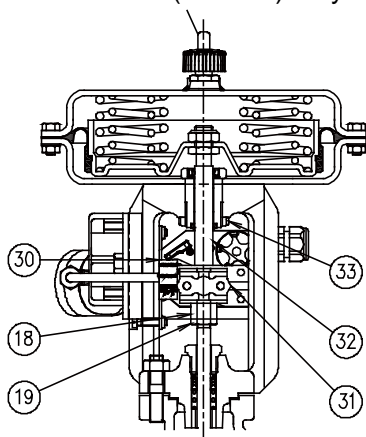

No.	Description	A*	B*	C*	D*
1	Main Body				
2	Separator Body				
3	Trap Cover				
4	Separator Screen				
5	Separator				
6	Wave Spring				
7	Separator Body Gasket	✓	✓		
8	Separator Body Bolt				
9	Float Cover				
10	Float				✓
11	Float Cover Bolt				
12	Washer				
13	Trap Cover Gasket	✓	✓		
14	Trap Valve Seat Gasket	✓		✓	
15	Trap Valve Seat			✓	
16	Trap Cover Bolt				
17	Valve Bonnet				
18	Stem Connector Nut				
19	Locknut				
20	Guide Bushing				
21	Stuffing Box V-ring Packing		✓		
22	Stuffing Box Washer				
23	Stuffing Box Spring		✓		
24	Plug			✓	
25	Valve Bonnet Gasket	✓	✓		
26	Valve Bonnet Bolt				
27	Valve Bonnet Nut				
28	Valve Seat			✓	
29	Nameplate				
30	Travel Indicator Scale				
31	Stem Bracket Clamp				
32	Actuator Stem				
33	Fixing Nut				

*Replacement parts are available only in the following kits:

- A = Maintenance Kit
- B = Repair Kit
- C = Repair Kit for Trap Valve Seat
- D = Float

CV-COS-20

Sizes 65 to 100 mm (2½ to 4 in)

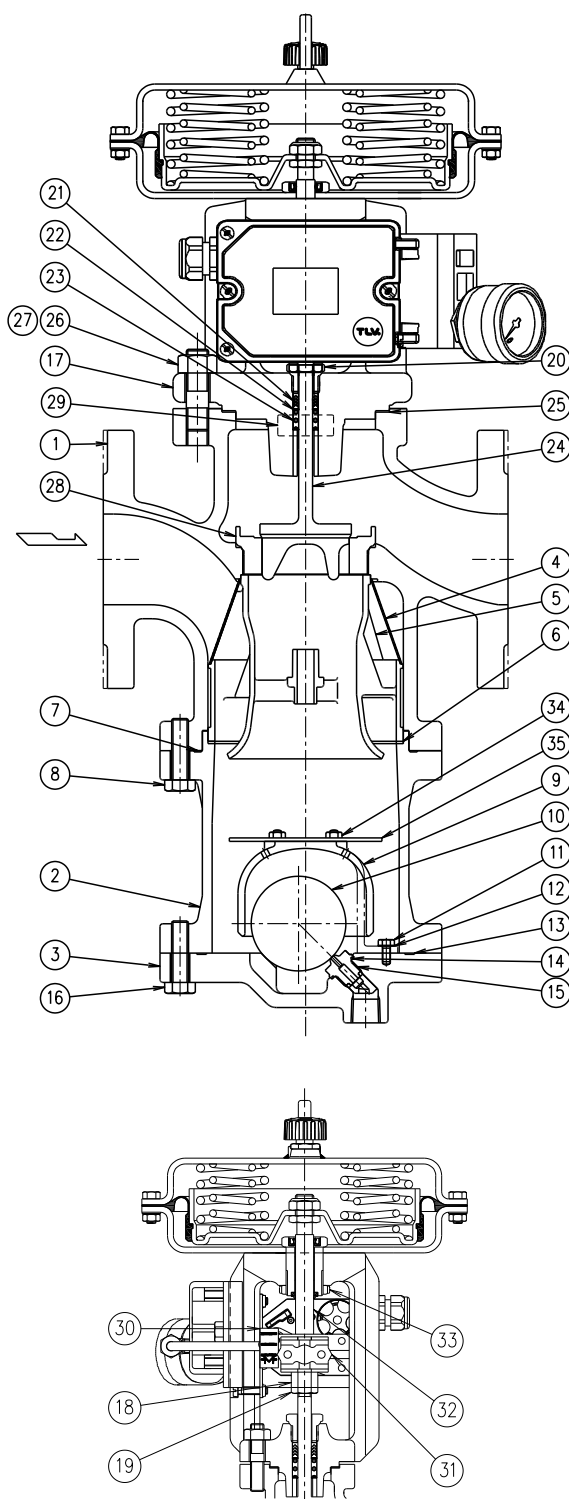

No.	Description	A*	B*	C*	D*
1	Main Body				
2	Separator Body				
3	Trap Cover				
4	Separator Screen				
5	Separator				
6	Wave Spring				
7	Separator Body Gasket	✓	✓		
8	Separator Body Bolt				
9	Float Cover				
10	Float				✓
11	Float Cover Bolt				
12	Washer				
13	Trap Cover Gasket	✓	✓		
14	Trap Valve Seat Gasket	✓		✓	
15	Trap Valve Seat			✓	
16	Trap Cover Bolt				
17	Valve Bonnet				
18	Stem Connector Nut				
19	Locknut				
20	Guide Bushing				
21	Stuffing Box V-ring Packing		✓		
22	Stuffing Box Washer				
23	Stuffing Box Spring		✓		
24	Plug		✓		
25	Valve Bonnet Gasket	✓	✓		
26	Valve Bonnet Bolt				
27	Valve Bonnet Nut				
28	Valve Seat		✓		
29	Nameplate				
30	Travel Indicator Scale				
31	Stem Bracket Clamps				
32	Actuator Stem				
33	Fixing Nut				
34	Baffle Nut				
35	Baffle				

*Replacement parts are available only in the following kits:

A = Maintenance Kit

B = Repair Kit

C = Repair Kit for Trap Valve Seat

D = Float

CV-COS-20D (Optional)

Sizes 15 to 50 mm (1/2 to 2 in)

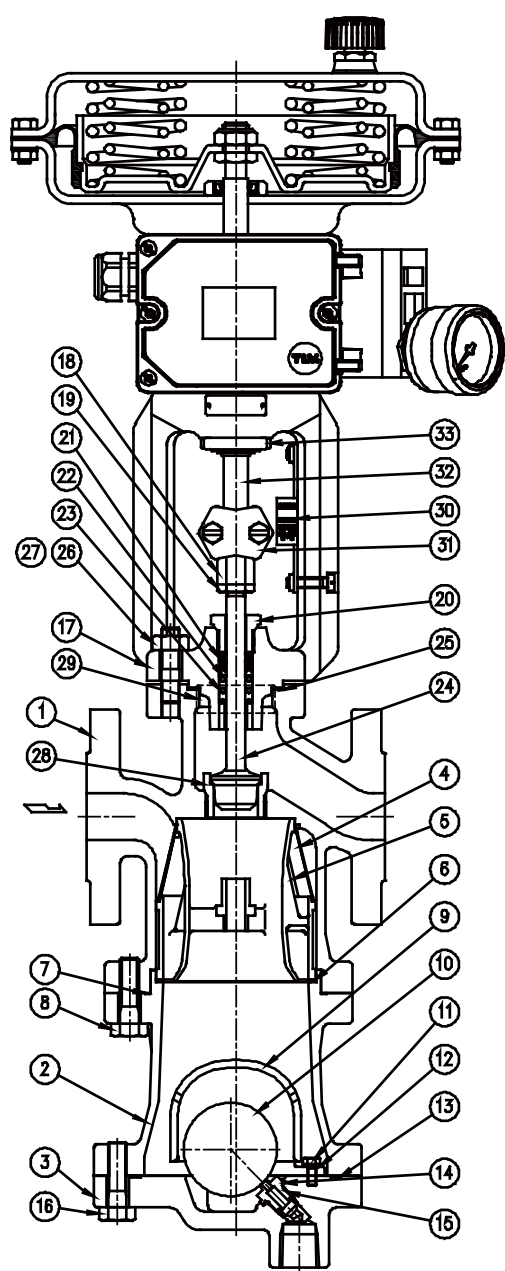

No.	Description	A*	B*	C*	D*
1	Main Body				
2	Separator Body				
3	Trap Cover				
4	Separator Screen				
5	Separator				
6	Wave Spring				
7	Separator Body Gasket	✓	✓		
8	Separator Body Bolt				
9	Float Cover				
10	Float				✓
11	Float Cover Bolt				
12	Washer				
13	Trap Cover Gasket	✓	✓		
14	Trap Valve Seat Gasket	✓		✓	
15	Trap Valve Seat			✓	
16	Trap Cover Bolt				
17	Valve Bonnet				
18	Stem Connector Nut				
19	Locknut				
20	Guide Bushing				
21	Stuffing Box V-ring Packing		✓		
22	Stuffing Box Washer				
23	Stuffing Box Spring		✓		
24	Plug			✓	
25	Valve Bonnet Gasket	✓	✓		
26	Valve Bonnet Bolt				
27	Valve Bonnet Nut				
28	Valve Seat		✓		
29	Nameplate				
30	Travel Indicator Scale				
31	Stem Bracket Clamps				
32	Actuator Stem				
33	Fixing Nut				

*Replacement parts are available only in the following kits:

- A = Maintenance Kit
- B = Repair Kit
- C = Repair Kit for Trap Valve Seat
- D = Float

CV-COS-20D (Optional)

Sizes 65 to 100 mm (2½ to 4 in)

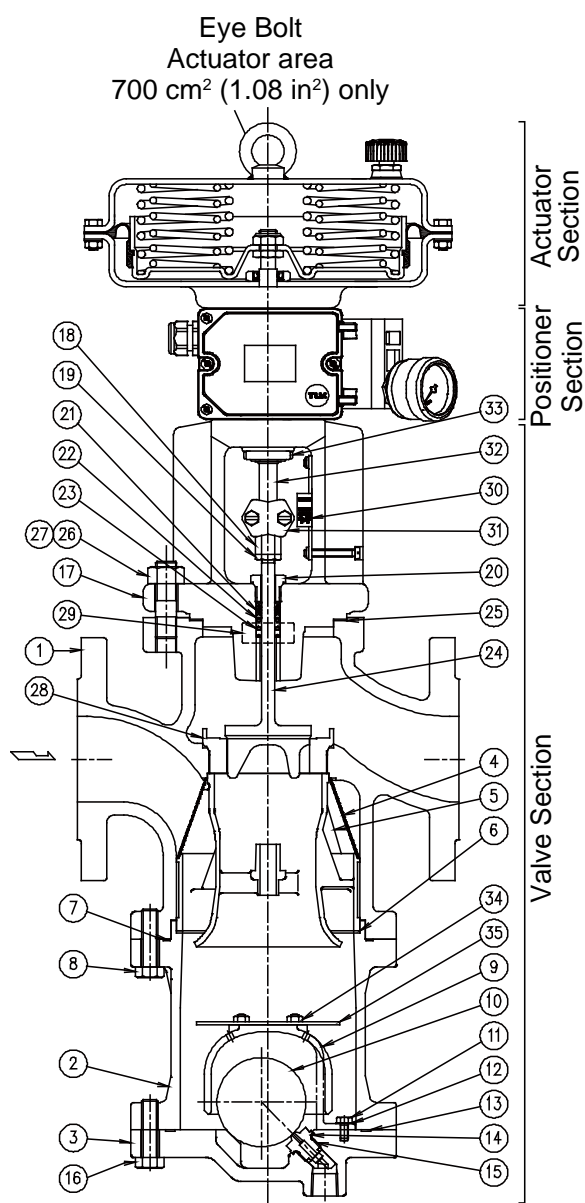

No.	Description	A*	B*	C*	D*
1	Main Body				
2	Separator Body				
3	Trap Cover				
4	Separator Screen				
5	Separator				
6	Wave Spring				
7	Separator Body Gasket	✓	✓		
8	Separator Body Bolt				
9	Float Cover				
10	Float				✓
11	Float Cover Bolt				
12	Washer				
13	Trap Cover Gasket	✓	✓		
14	Trap Valve Seat Gasket	✓		✓	
15	Trap Valve Seat			✓	
16	Trap Cover Bolt				
17	Valve Bonnet				
18	Stem Connector Nut				
19	Locknut				
20	Guide Bushing				
21	Stuffing Box V-ring Packing		✓		
22	Stuffing Box Washer				
23	Stuffing Box Spring		✓		
24	Plug		✓		
25	Valve Bonnet Gasket	✓	✓		
26	Valve Bonnet Bolt				
27	Valve Bonnet Nut				
28	Valve Seat		✓		
29	Nameplate				
30	Travel Indicator Scale				
31	Stem Bracket Clamps				
32	Actuator Stem				
33	Fixing Nut				
34	Baffle Nut				
35	Baffle				

*Replacement parts are available only in the following kits:

A = Maintenance Kit

B = Repair Kit

C = Repair Kit for Trap Valve Seat

D = Float

Installation



Install properly and **DO NOT** use this product outside the recommended operating pressure, temperature and other specification ranges. Improper use may result in such hazards as damage to the product or malfunctions which may lead to serious accidents. Local regulations may restrict the use of this product to below the conditions quoted.



Use hoisting equipment for heavy objects (weighing approximately 20 kg (44 lb) or more). Failure to do so may result in back strain or other injury if the object should fall.



DO NOT use only the actuator eye bolt when hoisting or lifting the assembled product. Failure to observe this precaution may lead to product damage.

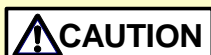

Take measures to prevent people from coming into direct contact with product outlets. Failure to do so may result in burns or other injury from the discharge of fluids.



Do not use excessive force when connecting threaded pipes to the product. Over-tightening may cause breakage leading to fluid discharge, which may cause burns or other injury.

Installation, inspection, maintenance, repairs, disassembly and adjustment and valve opening/closing should be carried out only by trained maintenance personnel.

Check to make sure that the piping where the product is to be installed is constructed properly. If the piping is not correctly constructed, the valve may not perform optimally.

1. Blowdown

Before installing the product, be sure to blow down all piping thoroughly.

If this is not possible, perform a blowdown using the bypass valve.

Blowdown is especially important for newly installed piping or after the system has been shut down for a long period of time.

2. Installing the actuator section

The eye bolt welded onto the upper part of the diaphragm housing is for mounting and removing the actuator. Do not lift the assembled product using only the eye bolt.

(See Fig. 1)

3. Installing the control valve

Lift the assembled product using hoisting equipment such as cranes and forklifts. Do not lift the assembled product using only the eye bolt. (See Fig. 2)

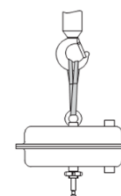

Fig. 1
Hoisting the actuator

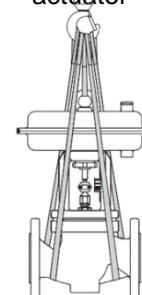
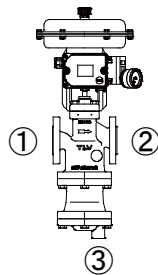

Fig. 2
Hoisting the control valve

4. Removing any protective caps and seals

Before installation, be sure to remove all protective seals and caps. (Found in three locations, on the product inlet and outlets.)



CV-COS-20

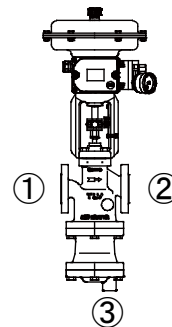

CV-COS-20D

5. Installation angle

Install the product so that the arrow mark on the valve body points horizontally in the direction of steam flow, and it should be installed horizontally in the piping with the actuator at the top. Allowable inclination is 10 degrees in the fore-aft direction and 15 degrees in the plane perpendicular to the steam flow line.

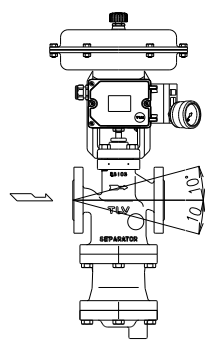

CV-COS-20

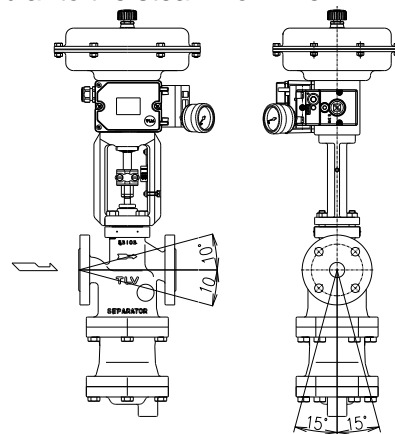
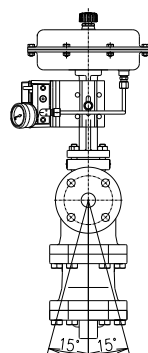

CV-COS-20D

6. Piping support

Install the product, paying attention to avoid excessive load, bending and vibration. Support the inlet and outlet pipes securely.

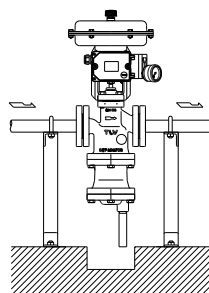

CV-COS-20

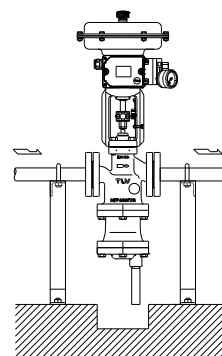

CV-COS-20D

7. Maintenance space

Leave sufficient space for maintenance, inspection and repair. (Units: mm)

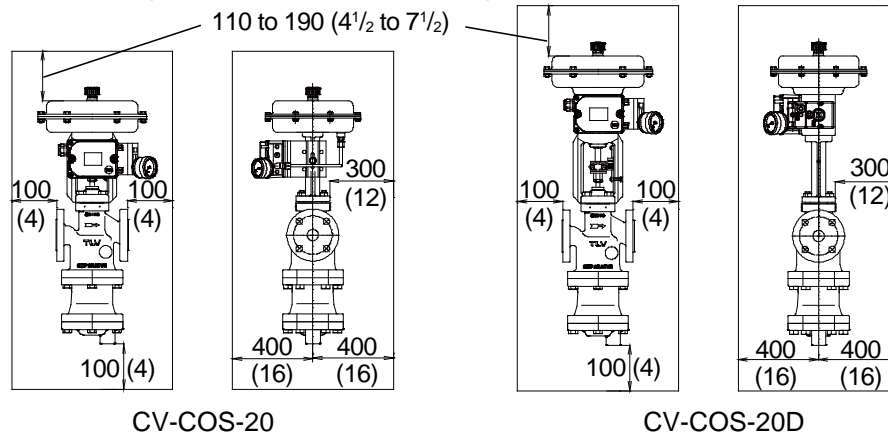

8. Trap outlet pipe

For ease of maintenance, installation of a union connection is recommended for the trap outlet pipe.

Connect the outlet pipe to a condensate return line, or extend it to a trench. In the case of the latter, make sure the end of the pipe is above the waterline. (Dirt and water may be sucked up by the vacuum formed during trap closure and system shutdown.) If the end must be underwater, make sure the piping has a small hole, as shown in the drawing below.

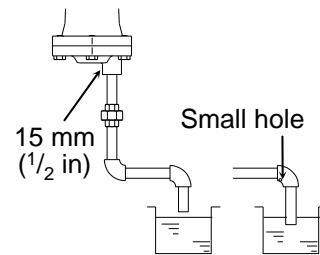

9. Accessories

Always install a shut-off valve, pressure gauge and bypass lines at both inlet and outlet. Ball valves, which will not retain condensate, are recommended for inlet and outlet shut-off valves. The bypass pipe should be at least 1/2 of the size of the inlet (primary side) pipe.

10. Installation environment

Check the installation environment to make sure that the ambient temperature does not exceed the actuator ambient temperature limit and that no corrosive gasses are present.

11. Installing the shut-off valve

Though the product adequately performs the function of a shut-off valve initially, extended use will result in a drop in its performance as an isolation valve. Be sure to install a separate shut-off or automatic valve if complete isolation is needed.

12. Installing the safety valve

When installing a safety valve, be sure not to install it between the control valve and the shut-off valve. It must be installed near the equipment it is to protect, on the outlet side of the shut-off valve.

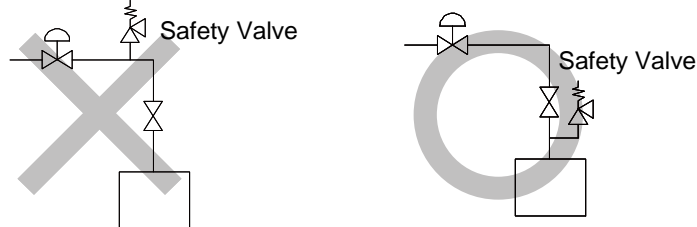

13. Avoid foreign matter and water hammer

Do not install in locations in the piping where foreign matter accumulates or where impact from water pressure (water hammer) occurs.

14. Piping gaskets

Be careful that the piping gaskets do not protrude outside the inner bore of the flange. The type of medium being used and the temperature must be taken into account in order to select a gasket of a suitable material.

15. Air line blowdown/purge

Before connecting the air lines for the motive air that is to be piped to the actuator, blow out the air in the lines to purge any dirt, foreign matter, oil or water from inside of the piping.

16. Quality of motive air

Supply to the actuator only clean air that does not contain water, oil or foreign matter.

To prevent malfunction due to contamination of the air supply, installation of the optional air filter regulator (5 μm filter) and mist separator (0.3 μm filter) as a set is recommended.

If air quality results in operation failure, the entire actuator unit (including the integrated positioner) must be replaced.

If there is a problem in operation, determine the cause using the “Troubleshooting” section in this manual.

Maintenance



Take measures to prevent people from coming into direct contact with product outlets. Failure to do so may result in burns or other injury from the discharge of fluids.



When disassembling or removing the product, wait until the internal pressure equals atmospheric pressure and the surface of the product has cooled to room temperature. Disassembling or removing the product when it is hot or under pressure may lead to discharge of fluids, causing burns, other injuries or damage.



Be sure to use only the recommended components when repairing the product, and NEVER attempt to modify the product in any way. Failure to observe these precautions may result in damage to the product or burns or other injury due to malfunction or the discharge of fluids.

Operational Check

An inspection of the following items should be done on a daily basis to determine whether the product is operating properly or has failed. Periodically (at least biannually) the operation should also be checked.

In the event of failure (malfunction), also refer to the "Troubleshooting" section for remedies.

Inspection Item	Inspection Points	Remedy for Failure (Malfunction)
Leakage from valve (when the valve is closed)	Visual inspection or stethoscope inspection; is the outlet side pressure or temperature elevated, or is there the sound of the medium flowing?	Adjust the zero/span; if that does not solve the problem, replace with a new valve plug & stem and valve seat
Leakage from gland area	Visual inspection; is fluid leaking from the gap between the guide bushing and the valve stem, or are there signs it has leaked previously?	Coat the guide bushing and the valve stem with grease; if that does not solve the problem, replace with new V-ring packing
Leakage from the gaskets between any pressurized parts	Visual inspection; is fluid leaking from the gasket areas on pressurized parts?	Apply additional tightening (refer to recommended torque) or replace with new gaskets
Leakage from pressurized parts such as body and valve bonnet	Visual inspection; is fluid leaking from pressurized parts such as the body or valve bonnet?	Replace any pressurized parts at leak locations
Leakage from the trap area	Visual inspection or stethoscope inspection; is live steam being discharged from the trap outlet piping, or can the sound of a steam leak be heard?	Clean the sealing surface of the trap valve seat or replace the valve seat

Parts Inspection

When parts have been removed, use the following table to inspect the parts and replace any that are found to be defective.

Inspection Item
Gasket(s): Check for warping and damage (Graphite gaskets MUST be replaced if disassembled)
Stuffing Box V-ring Packing: Check for warping or damage
Valve Plug & Stem, Valve Seat: Check for damage or scratches
Separator Screen: Check for clogging and corrosion
Trap Valve Seat: Check for scratches, dents, etc.
Float: Check for scratches, dents, etc.

Disassembly/Reassembly



When disassembling or removing the product, wait until the internal pressure equals atmospheric pressure and the surface of the product has cooled to room temperature. Disassembling or removing the product when it is hot or under pressure may lead to discharge of fluids, causing burns, other injuries or damage.



Be sure to use only the recommended components when repairing the product, and NEVER attempt to modify the product in any way. Failure to observe these precautions may result in damage to the product or burns or other injury due to malfunction or the discharge of fluids.

Use the following procedures to remove components. Use the same procedures in reverse to reassemble. (Installation, inspection, maintenance, repairs, disassembly, adjustment and valve opening/closing should be carried out only by trained maintenance personnel.)

For details of the actuator and the electro-pneumatic digital positioner, refer to the respective instruction manuals issued by the manufacturer.

Refer to “Disassembling/Reassembling the Valve and Actuator Sections” on the following page when removing the actuator section.

Consult the table of tightening torques when mounting the actuator section on the valve section.

NOTE: Be sure to coat all threaded portions of the valve seat and bolts with anti-seize.

Removing/Reattaching the Actuator (Positioner)

Part	During Disassembly	During Reassembly
Stem Bracket Bolt	Loosen stem bracket bolts and remove the stem bracket clamps connecting the actuator stem and stem connector nut	Consult the table of tightening torques and tighten to the proper torque
—	When an input signal is sent to the positioner, the actuator stem will ascend.	—
Fixing Nut	Remove the fixing nut connecting the actuator and the valve bonnet while keeping the actuator stem in the raised position	Consult the table of tightening torques and tighten to the proper torque

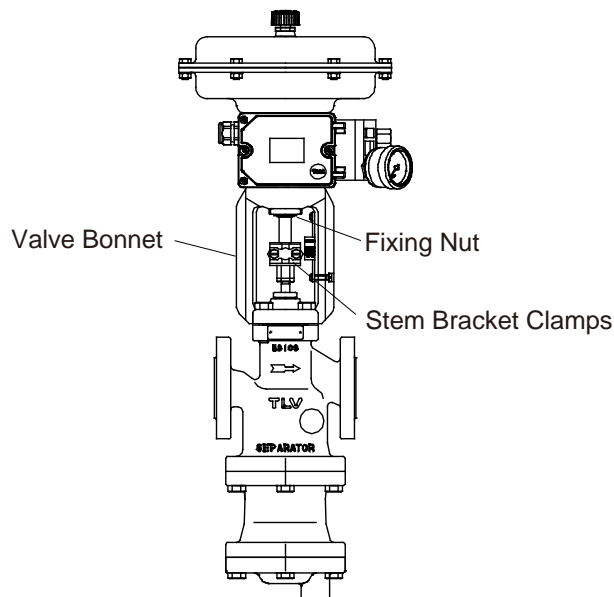

Detaching/Reattaching the Stem Connector Nut and Locknut

Part	During Disassembly	During Reassembly
Locknut, Stem Connector Nut	Loosen the locknut by holding the stem connector nut with a spanner <u>DO NOT disassemble with the valve plug in contact with the valve seat, make sure that the valve plug is slightly suspended</u>	Do not supply air to the actuator at a pressure of 0.6 MPaG (85 psig, 6 barg) or more. Consult the table of tightening torques and tighten to the proper torque If the instructions given are not followed when reassembly is carried out, malfunctions such as insufficient lift (insufficient flow capacity) and/or insufficient closing force (valve leakage) may result: give the proper attention to the adjustment procedure

NOTE: Be careful not to pinch your fingers between the valve stem and actuator stem!

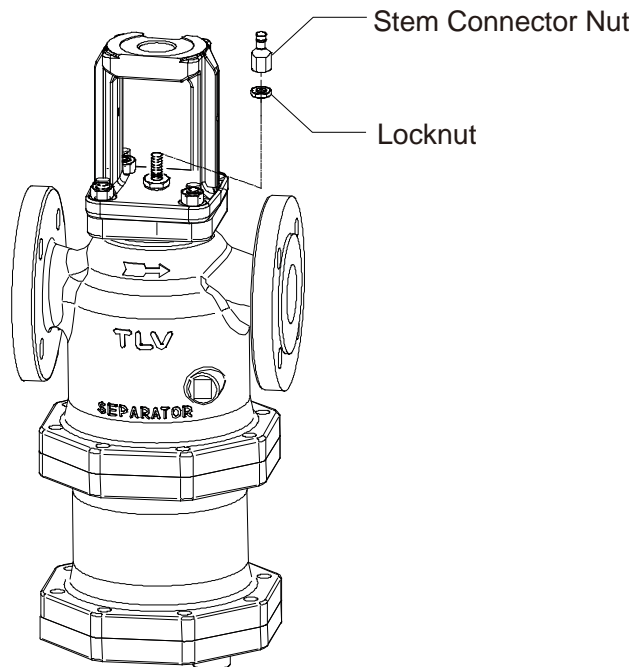

Instructions for Reverse Action (Air to Open, Fail Closed) Stroke Adjustment

1. Make sure that the valve plug is securely seated in the valve seat. (Fig. 1)
2. Supply the maximum air pressure (0.33 MPaG (48 psig, 3.3 barg)) of the spring range (e.g. 0.09 to 0.33 MPaG (13 to 48 psig, 0.9 to 3.3 barg)) to the actuator. (Refer to the nameplate, drawing or specification data sheet (SDS) for the spring range.)

With the actuator stem raised, screw the locknut and stem connector nut into the guide bushing as far as possible without touching the valve stem. (Fig. 2)

3. Supply the lower limit air pressure (0.09 MPaG (13 psig, 0.9 barg)) of the spring range (e.g. 0.09 to 0.33 MPaG (13 to 48 psig, 0.9 to 3.3 barg)) to the actuator. The actuator stem will descend. (Fig. 3)

NOTE: Be careful not to pinch your fingers.

4. Turn the stem connector nut until it comes into contact with the actuator stem, and turn the stem connector nut a further 1/4 turn to contact the actuator stem. Make sure that the valve plug is seated in the valve seat.

Hold the stem connector nut with a spanner and tighten the locknut with a proper torque. (Fig. 4)

5. Shut off the air supply to the actuator.

NOTE: Be careful not to pinch your fingers.

6. Secure the stem connector nut and the actuator stem with the stem bracket clamps. Make sure to adjust the stem bracket clamps to 0% (fully closed) on the travel indicator scale. (Fig. 5)

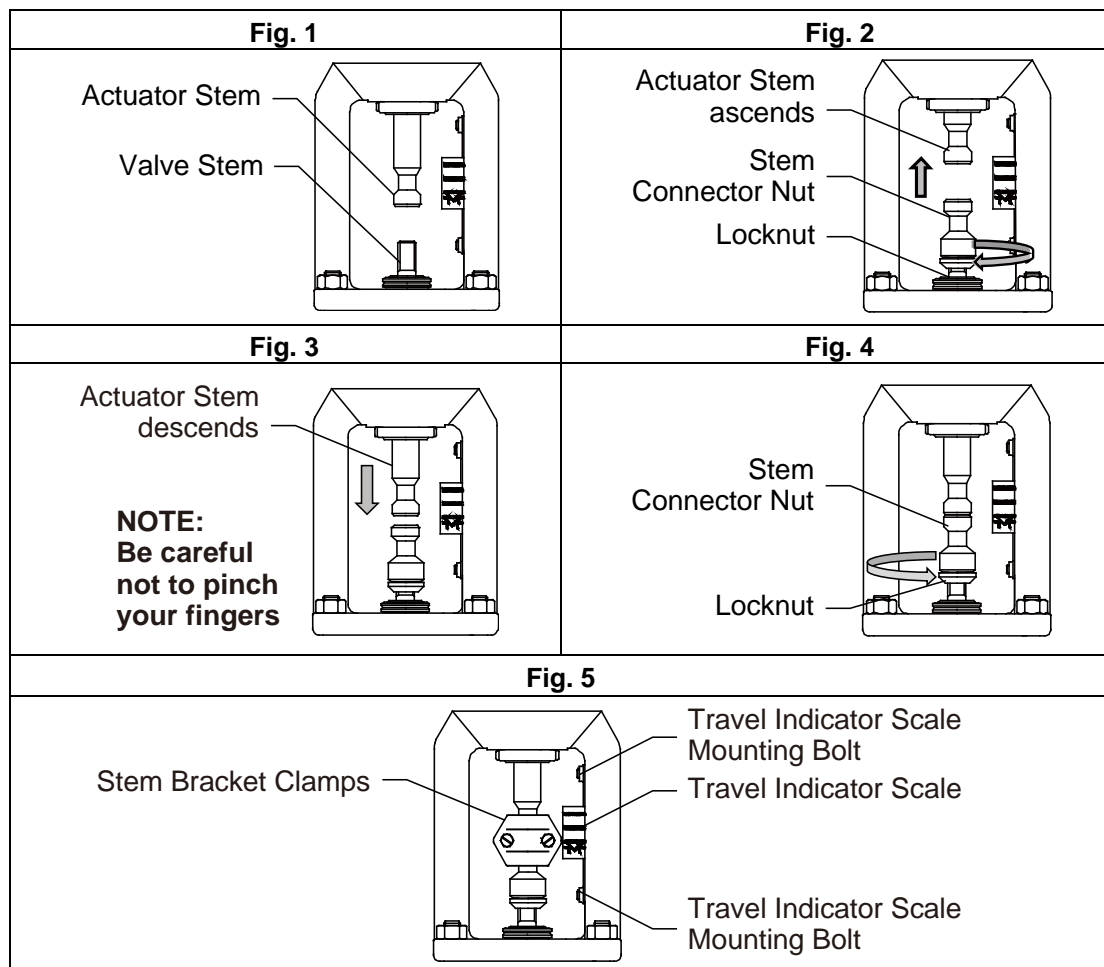

Instructions for Direct Action (Air to Close, Fail Open) Stroke Adjustment

1. Make sure that the valve plug is securely seated in the valve seat. (Fig. 1)
2. Screw the locknut and stem connector nut onto the valve stem until they are just short of coming into contact with the guide bushing. (Fig. 2)
3. Supply the upper limit air pressure (0.1 MPaG (15 psig, 1.0 barg)) of the spring range (e.g. 0.02 to 0.1 MPaG (3 to 15 psig, 0.2 to 1.0 barg)) to the actuator. The actuator stem will descend. (Fig. 3)
NOTE: Be careful not to pinch your fingers.
4. Turn the stem connector nut until it comes into contact with the actuator stem, and turn the stem connector nut a further 1/4 turn to contact the actuator stem. Make sure that the valve plug is seated in the valve seat. Hold the stem connector nut securely in place with a tool such as a spanner and tighten the locknut. (Fig. 4)
5. Shut off the air supply to the actuator.
NOTE: Be careful not to pinch your fingers.
6. Secure the stem connector nut and the actuator stem with the stem bracket clamps. Make sure to adjust the stem bracket clamps to 100% (fully open) on the travel indicator scale. (Fig. 5)

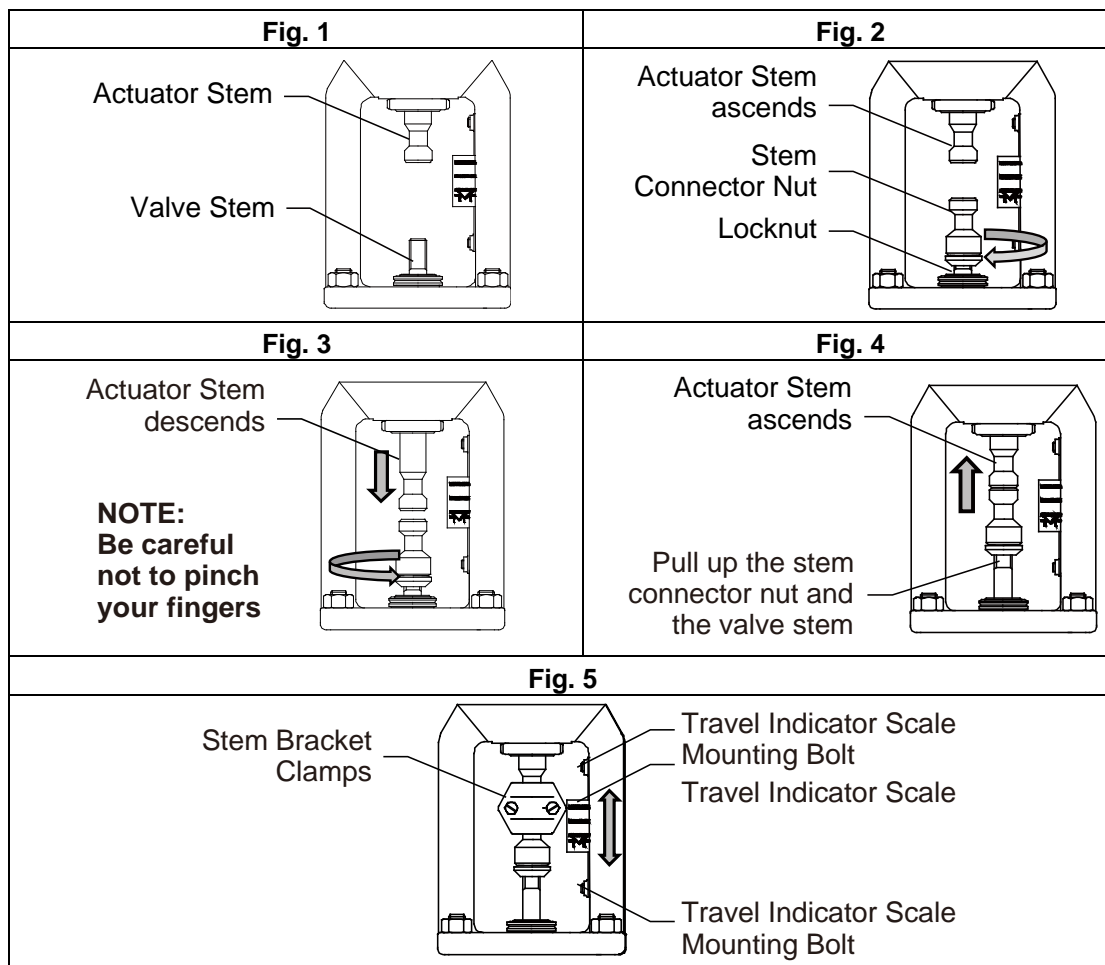

Disassembling/Reassembling the Gland and its Components

In the procedure below, first partially loosen the guide bushing and then remove the valve plug & stem before removing the other parts. (The procedure is most easily performed if the bushing is loosened while it is attached to the valve body.)

Part	During Disassembly	During Reassembly
Guide Bushing	Remove with a socket wrench	Consult the table of tightening torques and tighten to the proper torque
Stuffing Box V-ring Packing	Pull up and out	Make sure to reassemble the V-ring packing in the proper orientation; coat the groove with heat-resistant silicon grease; <u>reattach the V-ring packing with the grooves facing downward</u>
Stuffing Box Washer/ Stuffing Box Spring	Pull up and out	Reinsert

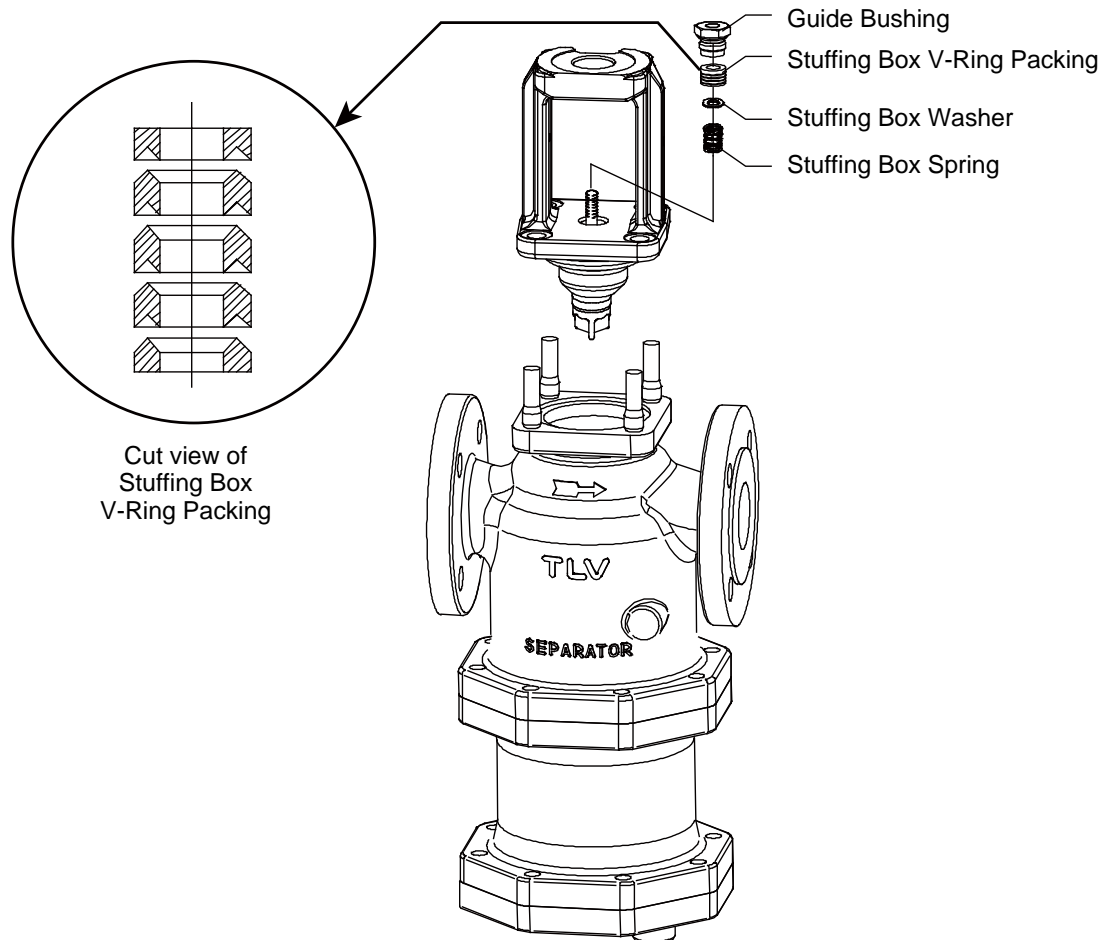

Disassembling/Reassembling of the Valve Bonnet Section

Part	During Disassembly	During Reassembly
Nut	Remove with a socket wrench	Consult the table of tightening torques and tighten to the proper torque, making sure to tighten evenly
Valve Bonnet	Pull up and off, being careful not to damage the valve plug or valve seat	Reattach, being careful not to damage the valve plug or valve seat; insert the bonnet securely into the gasket housing without tilting; <u>check to make sure that there is no catching or biting when the valve plug is seated in the valve seat, and that the valve plug is securely seated in the valve seat</u>
Valve Bonnet Gasket	Remove the gasket and clean sealing surfaces	Replace with a new gasket; make sure that the gasket does not protrude from the housing in the body; DO NOT coat with anti-seize

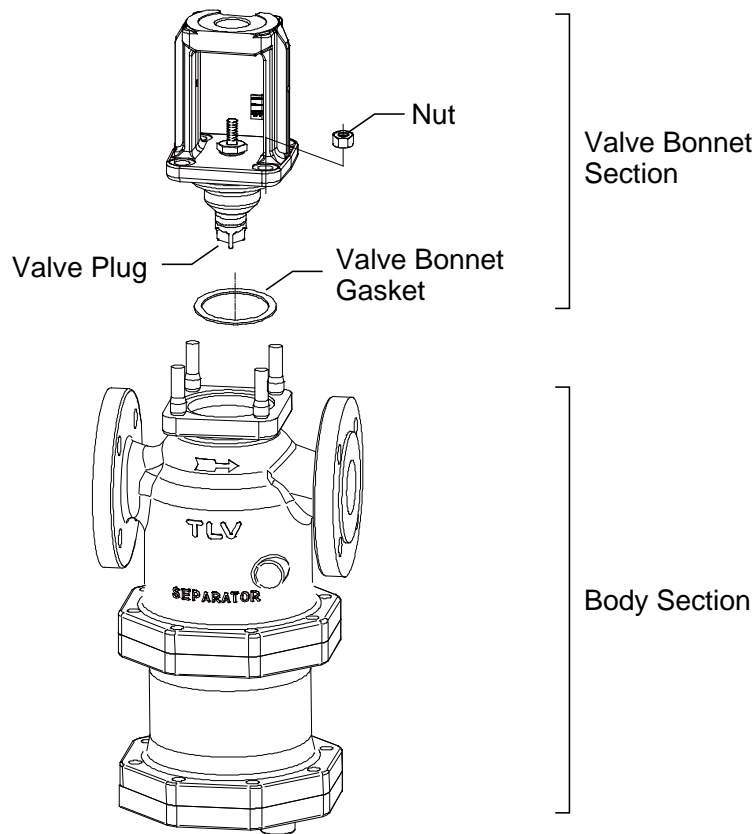

Disassembling/Reassembling the Valve Plug & Stem

After pulling out the valve plug, remove the loosened guide bushing, stuffing box V-ring packing, washer and coil spring.

Part	During Disassembly	During Reassembly
Valve Plug & Stem	—	When the Cv value is 30 or greater, be careful of the orientation of the valve wing-blades during reassembly; improper orientation can result in noise or erosion of the valve plug and/or valve seat

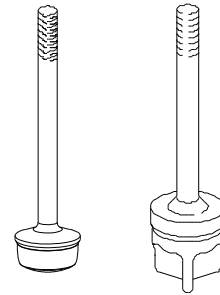

Cv Value: 20 or less Cv Value: 30 or more

NOTE: Valve reassembly orientation for Cv values of 30 or greater. (When the Cv value is 20 or less, there is no designated reassembly orientation.)

Valve Plug: Viewed from side

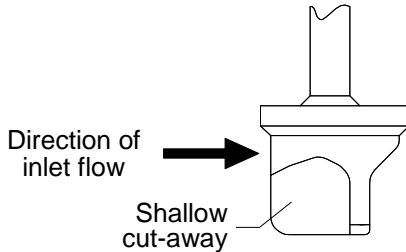

Valve Plug: Viewed from bottom

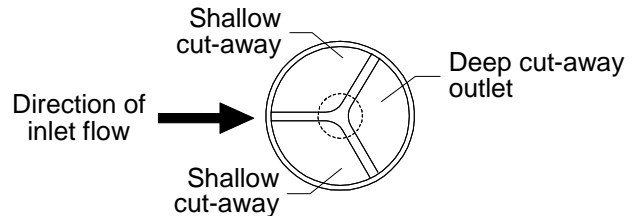

Removing/Reinserting the Valve Seat (Special tool required)

Part	During Disassembly	During Reassembly
Valve Seat	This procedure requires a special tool; contact TLV for details	Over-tightening could result in damage to the valve seat and body; consult the table of tightening torques and tighten to the proper torque

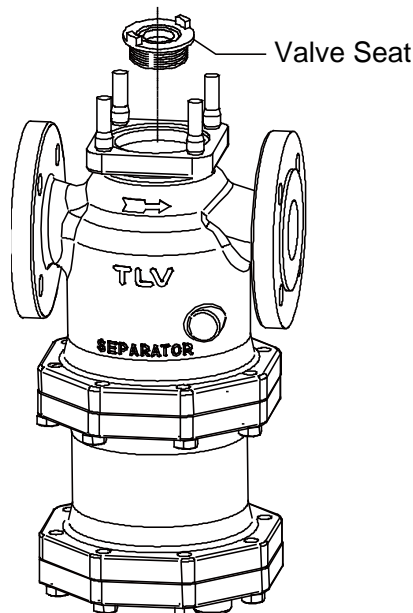

Removing/Reattaching the Separator and its Components

Part	During Disassembly	During Reassembly
Separator Body Bolt	Remove with a socket wrench When lifting the main body, be careful not to let the separator fall out	Consult the table of tightening torques and tighten to the proper torque
Separator Screen	Remove the separator screen	Being careful not to bend it, insert it securely onto the slanted part of the separator
Separator	Remove the separator	Insert it into the groove in the main body
Wave Spring	Remove the wave spring	Insert it into the groove in the trap body

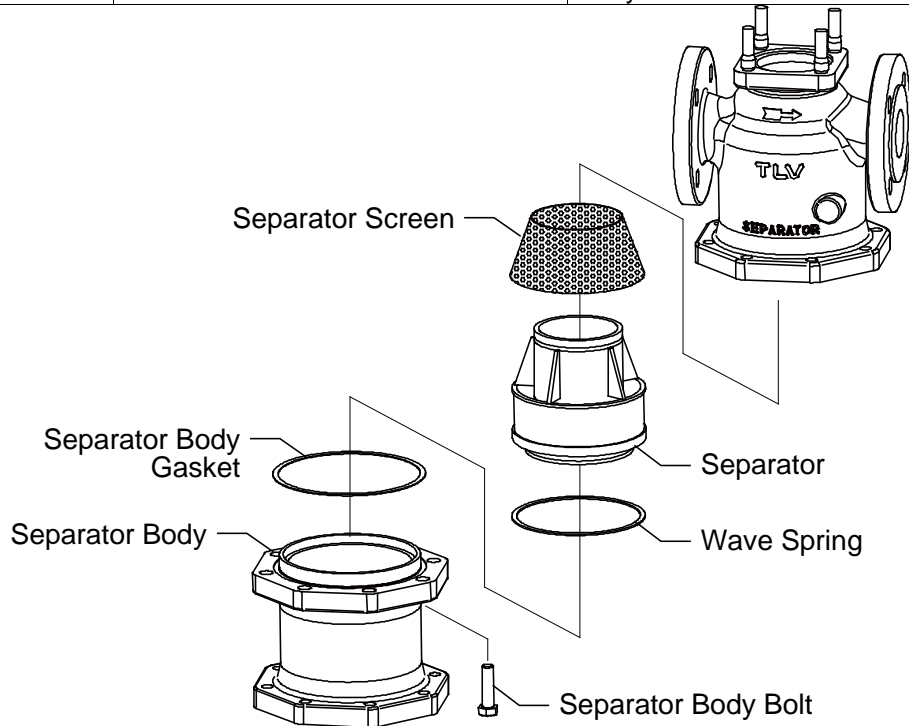

Removing/Reattaching the Trap and its Components

Part	During Disassembly	During Reassembly
Bolts for Trap Cover/Float Cover Bolt & Spring Washers	Remove with a socket wrench	Consult the table of tightening torques and tighten to the proper torque
Float Cover	Pull up and off	Replace with a new float cover
Float	Remove, being careful not to scratch the polished surface	Insert, being careful not to scratch the polished surface
Trap Valve Seat	Remove with a socket wrench	Consult the table of tightening torques and tighten to the proper torque
Trap Valve Seat Gasket	Remove the gasket and clean sealing surfaces	Replace with a new gasket if warped or damaged
Trap Cover Gasket	Remove the gasket and clean sealing surfaces	Replace with a new gasket if warped or damaged

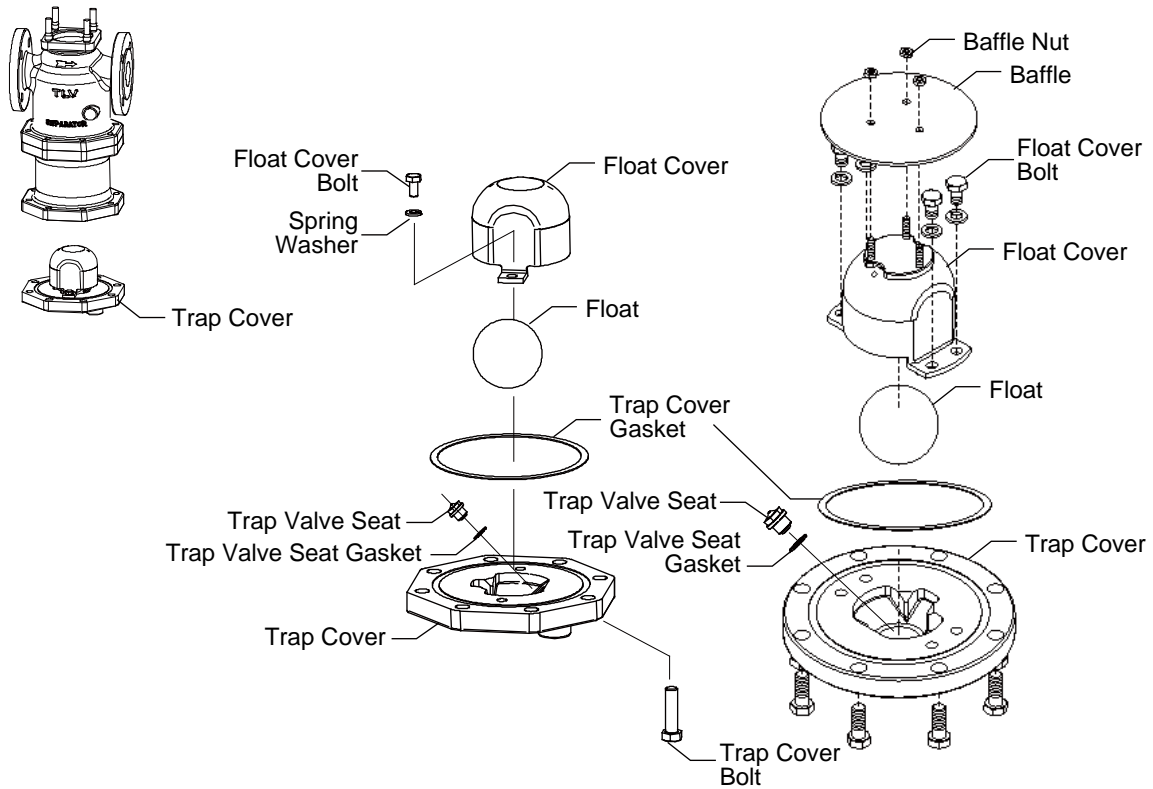

Table of Tightening Torques

Part	Size		Torque		Distance Across Flats	
	mm	(in)	N·m	(lbf·ft)	mm	(in)
Guide Bushing	15 to 80	(1/2 to 3)	50	(37)	24	(15/16)
	100	(4)	80	(59)	27	(11/16)
Valve Bonnet Nut	15 to 25	(1/2 to 1)	30	(22)	16 ¹⁾	(5/8) ¹⁾
					17 ¹⁾	21/32 ¹⁾
	40, 50	(1 1/2, 2)	50	(37)	18 ¹⁾	(11/16) ¹⁾
					19 ¹⁾	(3/4) ¹⁾
	65, 80	(2 1/2, 3)	100	(73)	24	(15/16)
100	(4)	150	(110)	30	(13/16)	
Valve Seat	15 to 25	(1/2 to 1)	170	(124)	Special tool required ²⁾	
	40, 50	(1 1/2, 2)	500	(368)		
	65, 80	(2 1/2, 3)	1050	(774)		
	100	(4)	1550	(1143)		
Trap Cover Bolt	15 to 40	(1/2 to 1 1/2)	60	(44)	16 ¹⁾	(5/8) ¹⁾
					17 ¹⁾	(21/32) ¹⁾
	50, 65, 80	(2, 2 1/2, 3)	70	(51)	18 ¹⁾	(11/16) ¹⁾
					19 ¹⁾	(3/4) ¹⁾
100	(4)	150	(110)	24	(15/16)	
Float Cover Bolt	15 to 20	(1/2 to 3/4)	7	(5.1)	8	(5/16)
	25 to 40	(1 to 1 1/2)	10	(7)	10	(3/8)
	50 to 100	(2 to 4)	20	(15)	13 ¹⁾	(1/2) ¹⁾
					14 ¹⁾	(9/16) ¹⁾
Trap Valve Seat	15 to 20	(1/2 to 3/4)	10	(7)	11	(7/16)
	25 to 40	(1 to 1 1/2)	15	(11)	13 ¹⁾	(1/2) ¹⁾
					14 ¹⁾	(9/16) ¹⁾
	50 to 80	(2 to 3)	40	(29)	16 ¹⁾	(5/8) ¹⁾
					17 ¹⁾	(21/32) ¹⁾
100	(4)	55	(40)	19	(3/4)	
Fixing Nut	15 to 100	(1/2 to 4)	150	(110)	Special tool required ²⁾	
Stem Connector Nut, Locknut	15 to 80	(1/2 to 3)	50	(37)	16 ¹⁾	(5/8) ¹⁾
					17 ¹⁾	21/32 ¹⁾
	100	(4)	120	(88)	24	(15/16)
Stem Bracket Bolt	240 cm ^{2 3)}	(0.37 in ^{2 3)})	5	(4)	8	(5/16)
	350 cm ^{2 3)}	(0.54 in ^{2 3)})	9	(6.5)	9	(11/32)
	700 cm ^{2 3)}	(1.08 in ^{2 3)})	9	(6.5)	9	(11/32)

¹⁾ Size depends on bolt specifications.

(1 N·m ≈ 10 kg·cm)

²⁾ Contact TLV for details.

³⁾ Actuator area

NOTE: -Coat all threaded portions with anti-seize.

(1 N·m ≈ 10 kg·cm)

-If drawings or other special documentation were supplied for the product, any torque given there takes precedence over values shown here.

Exploded View

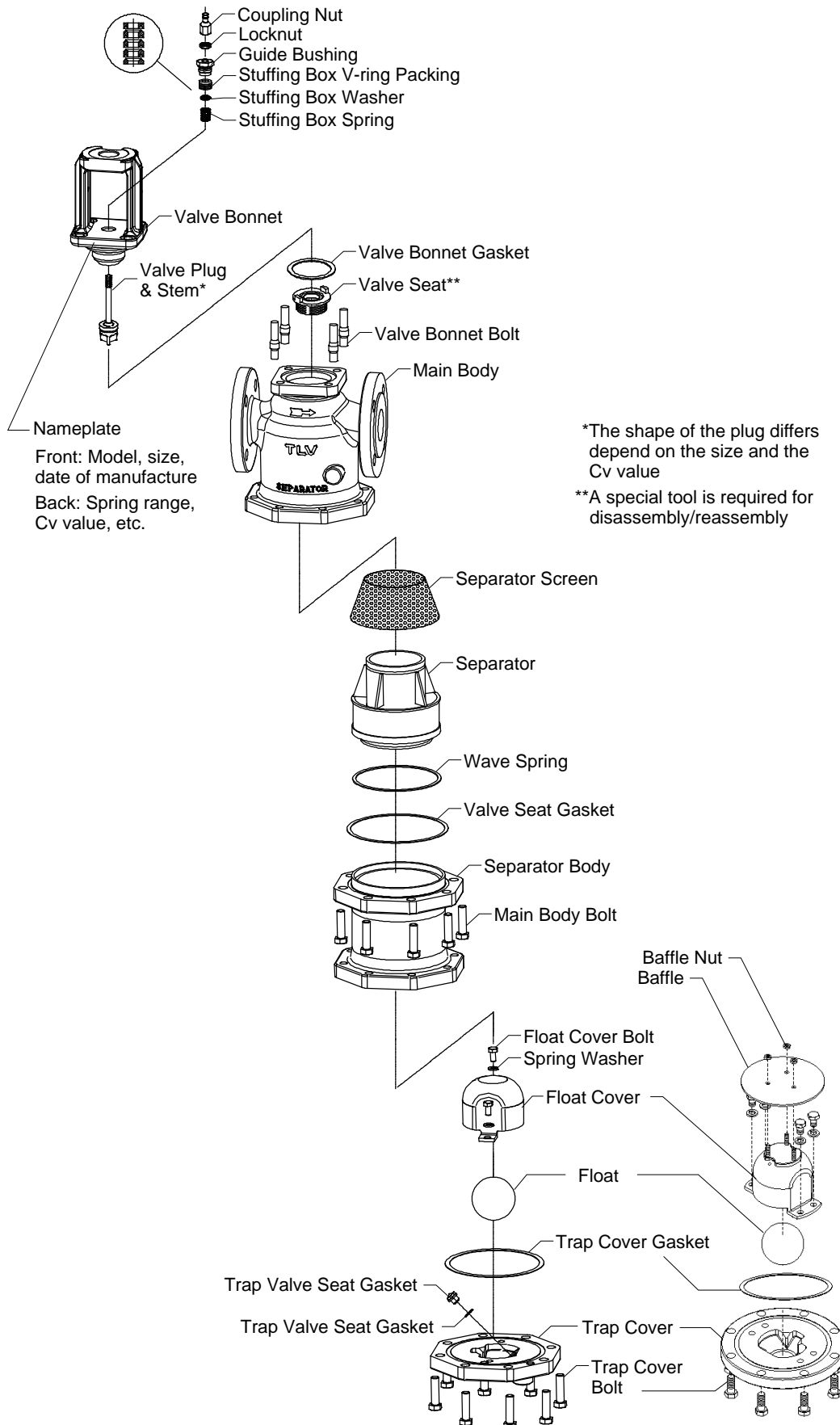

Troubleshooting



When disassembling or removing the product, wait until the internal pressure equals atmospheric pressure and the surface of the product has cooled to room temperature. Disassembling or removing the product when it is hot or under pressure may lead to discharge of fluids, causing burns, other injuries or damage.

When the valve unit fails to operate properly, use the following table to locate the cause and remedy. When the actuator and positioner fail to operate properly, refer to the applicable manual.

Valve Section

Problem	Cause	Diagnosis	Remedy (Countermeasure)
Valve Leakage	The pressure of the air supply to the actuator or positioner is too high	Check the pressure of the air supply to the actuator and positioner (confirm product specifications on the nameplate)	Adjust the pressure of the air supply for the positioner to match the pressure in the product specifications Refer to the instruction manual for the positioner for zero point adjustment
	The positioner's zero point is miscalibrated	Check the actuator air supply pressure (on the positioner's pressure gauge) when the operation signal is at zero point	If the pressure on the pressure gauge is elevated, adjust the positioner's zero point (refer to the instruction manual for positioner)
	The inlet pressure for the control valve is too high	Check the inlet pressure for the control valve	Decrease the inlet pressure (Cv value and the spring range must be changed)
	The valve plug and valve seat are off-center	Move the valve plug & stem up and down and check to see if it catches	Reassemble the valve bonnet section correctly
	Wear of the sealing surfaces of the valve plug and valve seat	Check the valve plug and valve seat	Replace the valve plug and valve seat. Consider replacing with a valve plug and valve seat of a more durable material.

Steam Trap Section

Problem	Cause	Diagnosis	Remedy (Countermeasure)
Steam is blowing	There is a build-up of dirt on the trap valve seat or on the float	Check the trap valve seat and the float	Clean or replace with a new trap valve seat or float
	The body is installed tilted	Check the installation conditions	Correct the installation
	The float is deformed	Check the float	Replace with a new float (Inspect for water hammer or freezing)
	There is vibration in the piping	Check the piping conditions	Remove the source of the vibration or reinforce the piping supports
No condensate is discharged	The primary pressure exceeds the trap valve seat maximum working pressure	Check the primary pressure	Decrease the inlet pressure to the maximum operating pressure (PMO) or less
	Water is inside the float	Check the float	Replace with a new float (Investigate to see if the flow medium contains corrosive substances)
	Output piping is clogged	Check the outlet piping	Clean or modify the piping
	The trap valve seat is clogged	Check the trap valve seat	Clean or replace with a new trap valve seat

TLV EXPRESS LIMITED WARRANTY

Subject to the limitations set forth below, TLV CO., LTD., a Japanese corporation (“**TLV**”), warrants that products which are sold by it, TLV International Inc. (“**TII**”) or one of its group companies excluding TLV Corporation (a corporation of the United States of America), (hereinafter the “**Products**”) are designed and manufactured by TLV, conform to the specifications published by TLV for the corresponding part numbers (the “**Specifications**”) and are free from defective workmanship and materials. The party from whom the Products were purchased shall be known hereinafter as the “**Seller**”. With regard to products or components manufactured by unrelated third parties (the “**Components**”), TLV provides no warranty other than the warranty from the third party manufacturer(s), if any.

Exceptions to Warranty

This warranty does not cover defects or failures caused by:

1. improper shipping, installation, use, handling, etc., by persons other than TLV, TII or TLV group company personnel, or service representatives authorized by TLV; or
2. dirt, scale or rust, etc.; or
3. improper disassembly and reassembly, or inadequate inspection and maintenance by persons other than TLV or TLV group company personnel, or service representatives authorized by TLV; or
4. disasters or forces of nature or Acts of God; or
5. abuse, abnormal use, accidents or any other cause beyond the control of TLV, TII or TLV group companies; or
6. improper storage, maintenance or repair; or
7. operation of the Products not in accordance with instructions issued with the Products or with accepted industry practices; or
8. use for a purpose or in a manner for which the Products were not intended; or
9. use of the Products in a manner inconsistent with the Specifications; or
10. use of the Products with Hazardous Fluids (fluids other than steam, air, water, nitrogen, carbon dioxide and inert gases (helium, neon, argon, krypton, xenon and radon)); or
11. failure to follow the instructions contained in the TLV Instruction Manual for the Product.

Duration of Warranty

This warranty is effective for a period of one (1) year after delivery of Products to the first end user. Notwithstanding the foregoing, asserting a claim under this warranty must be brought within three (3) years after the date of delivery to the initial buyer if not sold initially to the first end user.

ANY IMPLIED WARRANTIES NOT NEGATED HEREBY WHICH MAY ARISE BY OPERATION OF LAW, INCLUDING THE IMPLIED WARRANTIES OF MERCHANTABILITY AND FITNESS FOR A PARTICULAR PURPOSE AND ANY EXPRESS WARRANTIES NOT NEGATED HEREBY, ARE GIVEN SOLELY TO THE INITIAL BUYER AND ARE LIMITED IN DURATION TO ONE (1) YEAR FROM THE DATE OF SHIPMENT BY THE SELLER.

Exclusive Remedy

THE EXCLUSIVE REMEDY UNDER THIS WARRANTY, UNDER ANY EXPRESS WARRANTY OR UNDER ANY IMPLIED WARRANTIES NOT NEGATED HEREBY (INCLUDING THE IMPLIED WARRANTIES OF MERCHANTABILITY AND FITNESS FOR A PARTICULAR PURPOSE), IS **REPLACEMENT**; PROVIDED: (a) THE CLAIMED DEFECT IS

REPORTED TO THE SELLER IN WRITING WITHIN THE WARRANTY PERIOD, INCLUDING A DETAILED WRITTEN DESCRIPTION OF THE CLAIMED DEFECT AND HOW AND WHEN THE CLAIMED DEFECTIVE PRODUCT WAS USED; AND (b) THE CLAIMED DEFECTIVE PRODUCT AND A COPY OF THE PURCHASE INVOICE IS RETURNED TO THE SELLER, FREIGHT AND TRANSPORTATION COSTS PREPAID, UNDER A RETURN MATERIAL AUTHORIZATION AND TRACKING NUMBER ISSUED BY THE SELLER. ALL LABOR COSTS, SHIPPING COSTS, AND TRANSPORTATION COSTS ASSOCIATED WITH THE RETURN OR REPLACEMENT OF THE CLAIMED DEFECTIVE PRODUCT ARE SOLELY THE RESPONSIBILITY OF BUYER OR THE FIRST END USER. THE SELLER RESERVES THE RIGHT TO INSPECT ON THE FIRST END USER'S SITE ANY PRODUCTS CLAIMED TO BE DEFECTIVE BEFORE ISSUING A RETURN MATERIAL AUTHORIZATION. SHOULD SUCH INSPECTION REVEAL, IN THE SELLER'S REASONABLE DISCRETION, THAT THE CLAIMED DEFECT IS NOT COVERED BY THIS WARRANTY, THE PARTY ASSERTING THIS WARRANTY SHALL PAY THE SELLER FOR THE TIME AND EXPENSES RELATED TO SUCH ON-SITE INSPECTION.

Exclusion of Consequential and Incidental Damages

IT IS SPECIFICALLY ACKNOWLEDGED THAT THIS WARRANTY, ANY OTHER EXPRESS WARRANTY NOT NEGATED HEREBY, AND ANY IMPLIED WARRANTY NOT NEGATED HEREBY, INCLUDING THE IMPLIED WARRANTIES OF MERCHANTABILITY AND FITNESS FOR A PARTICULAR PURPOSE, DO NOT COVER, AND NEITHER TLV, TII NOR ITS TLV GROUP COMPANIES WILL IN ANY EVENT BE LIABLE FOR, INCIDENTAL OR CONSEQUENTIAL DAMAGES, INCLUDING, BUT NOT LIMITED TO LOST PROFITS, THE COST OF DISASSEMBLY AND SHIPMENT OF THE DEFECTIVE PRODUCT, INJURY TO OTHER PROPERTY, DAMAGE TO BUYER'S OR THE FIRST END USER'S PRODUCT, DAMAGE TO BUYER'S OR THE FIRST END USER'S PROCESSES, LOSS OF USE, OR OTHER COMMERCIAL LOSSES. WHERE, DUE TO OPERATION OF LAW, CONSEQUENTIAL AND INCIDENTAL DAMAGES UNDER THIS WARRANTY, UNDER ANY OTHER EXPRESS WARRANTY NOT NEGATED HEREBY OR UNDER ANY IMPLIED WARRANTY NOT NEGATED HEREBY (INCLUDING THE IMPLIED WARRANTIES OF MERCHANTABILITY AND FITNESS FOR A PARTICULAR PURPOSE) CANNOT BE EXCLUDED, SUCH DAMAGES ARE EXPRESSLY LIMITED IN AMOUNT TO THE PURCHASE PRICE OF THE DEFECTIVE PRODUCT. THIS EXCLUSION OF CONSEQUENTIAL AND INCIDENTAL DAMAGES, AND THE PROVISION OF THIS WARRANTY LIMITING REMEDIES HEREUNDER TO REPLACEMENT, ARE INDEPENDENT PROVISIONS, AND ANY DETERMINATION THAT THE LIMITATION OF REMEDIES FAILS OF ITS ESSENTIAL PURPOSE OR ANY OTHER DETERMINATION THAT EITHER OF THE ABOVE REMEDIES IS UNENFORCEABLE, SHALL NOT BE CONSTRUED TO MAKE THE OTHER PROVISIONS UNENFORCEABLE.

Exclusion of Other Warranties

THIS WARRANTY IS IN LIEU OF ALL OTHER WARRANTIES, EXPRESS OR IMPLIED, AND ALL OTHER WARRANTIES, INCLUDING BUT NOT LIMITED TO THE IMPLIED WARRANTIES OF MERCHANTABILITY AND FITNESS FOR A PARTICULAR PURPOSE, ARE EXPRESSLY DISCLAIMED.

Severability

Any provision of this warranty which is invalid, prohibited or unenforceable in any jurisdiction shall, as to such jurisdiction, be ineffective to the extent of such invalidity, prohibition or unenforceability without invalidating the remaining provisions hereof, and any such invalidity, prohibition or unenforceability in any such jurisdiction shall not invalidate or render unenforceable such provision in any other jurisdiction.

Service

For Service or Technical Assistance: Contact your TLV representative or your regional TLV office.

In Europe:

TLV EURO ENGINEERING GmbH

Daimler-Benz-Straße 16-18, 74915 Waibstadt, **Germany**

Tel: [49]-(0)7263-9150-0
Fax: [49]-(0)7263-9150-50

TLV EURO ENGINEERING UK LTD.

Units 7 & 8, Furlong Business Park, Bishops Cleeve, Gloucestershire GL52 8TW, **U.K.**

Tel: [44]-(0)1242-227223
Fax: [44]-(0)1242-223077

TLV EURO ENGINEERING FRANCE SARL

Parc d'Ariane 2, bât. C, 290 rue Ferdinand Perrier, 69800 Saint Priest, **France**

Tel: [33]-(0)4-72482222
Fax: [33]-(0)4-72482220

In North America:

TLV CORPORATION

13901 South Lakes Drive, Charlotte, NC 28273-6790, **U.S.A.**

Tel: [1]-704-597-9070
Fax: [1]-704-583-1610

In Mexico and Latin America:

TLV ENGINEERING S. A. DE C.V.

Av. Jesús del Monte 39-B-1001, Col. Hda. de las Palmas, Huixquilucan, Edo. de México, 52763, **Mexico**

Tel: [52]-55-5359-7949
Fax: [52]-55-5359-7585

In Oceania:

TLV PTY LIMITED

Unit 8, 137-145 Rooks Road, Nunawading, Victoria 3131, **Australia**

Tel: [61]-(0)3-9873 5610
Fax: [61]-(0)3-9873 5010

In East Asia:

TLV PTE LTD

36 Kaki Bukit Place, #02-01/02, **Singapore** 416214

Tel: [65]-6747 4600
Fax: [65]-6742 0345

TLV SHANGHAI CO., LTD.

Room 5406, No. 103 Cao Bao Road, Shanghai, **China** 200233

Tel: [86]-(0)21-6482-8622
Fax: [86]-(0)21-6482-8623

TLV ENGINEERING SDN. BHD.

No.16, Jalan MJ14, Taman Industri Meranti Jaya, 47120 Puchong, Selangor, **Malaysia**

Tel: [60]-3-8065-2928
Fax: [60]-3-8065-2923

TLV PRIVATE LIMITED

252/94 (K-L) 17th Floor, Muang Thai-Phatra Complex Tower B, Rachadaphisek Road, Huaykwang, Bangkok 10310, **Thailand**

Tel: [66]-2-693-3799
Fax: [66]-2-693-3979

TLV INC.

#302-1 Bundang Technopark B, 723 Pangyo-ro, Bundang, Seongnam, Gyeonggi, 13511, **Korea**

Tel: [82]-(0)31-726-2105
Fax: [82]-(0)31-726-2195

In the Middle East:

TLV ENGINEERING FZCO

Building 2W, No. M002, PO Box 371684, Dubai Airport Free Zone, Dubai, **UAE**

Email: sales-me@tlv.co.jp

In Other Countries:

TLV INTERNATIONAL, INC.

881 Nagasuna, Noguchi, Kakogawa, Hyogo 675-8511, **Japan**

Tel: [81]-(0)79-427-1818
Fax: [81]-(0)79-425-1167

Manufacturer:

TLV CO., LTD.

881 Nagasuna, Noguchi, Kakogawa, Hyogo 675-8511, **Japan**

Tel: [81]-(0)79-422-1122
Fax: [81]-(0)79-422-0112

Options



Install properly and **DO NOT** use this product outside the recommended operating pressure, temperature and other specification ranges. Improper use may result in such hazards as damage to the product or malfunctions which may lead to serious accidents. Local regulations may restrict the use of this product to below the conditions quoted.



Take measures to prevent people from coming into direct contact with product outlets. Failure to do so may result in burns or other injury from the discharge of fluids.

The following options are available to meet individual specification requirements, so please verify your particular product.

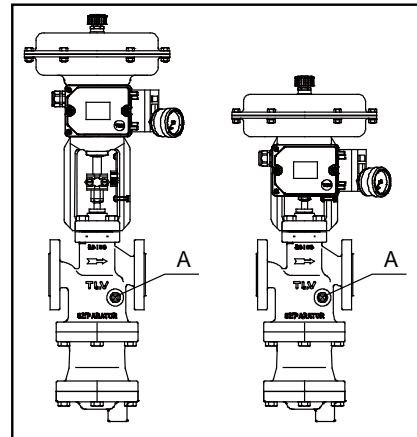

Body Options for Section A (Standard: No Plug)

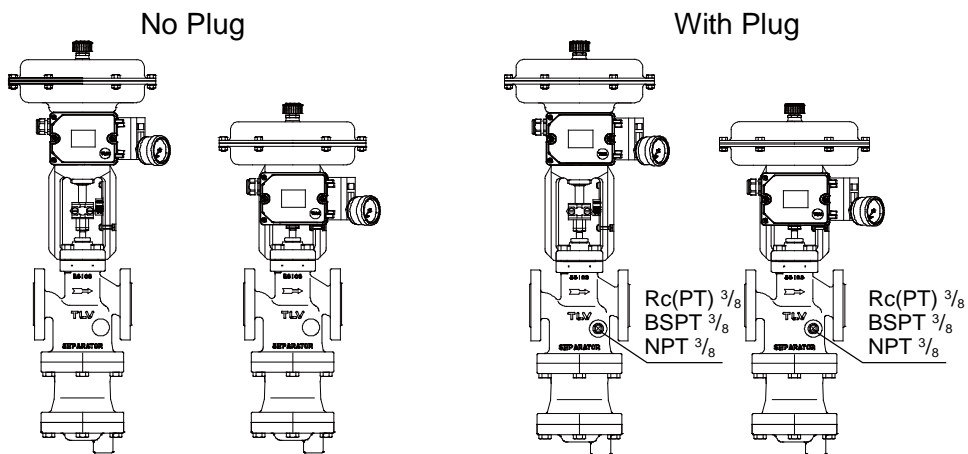

Torque		Dist. Across Flats	
N-m	(lb-ft)	mm	(in)
30	(22)	12	(1/2)

NOTE:
Wrap sealing tape 3 to 3.5 times around the threaded portions.
(1 N-m ≈ 10 kg-cm)

Applications for Use

Where there are large amounts of dirt or scale, or for applications such as heating in which the equipment is shut down for long periods of time, be sure to install a blow/purge valve.

1. Remove the plug (optional) from the main body and install the blow/purge valve.
2. Open the blow/purge valve and blow any residual dirt and scale off of the screen.
3. Periodically activate the blow/purge valve to keep the system free of dirt and scale.