

TLV[®]

COSPECT[®]

STEAM PRESSURE REDUCING VALVES

**Three-in-One
Pressure Regulator,
Separator, and
Steam Trap**



COSPECT:

Three-in-One Design

A Product of Advanced Fluid Control Technology

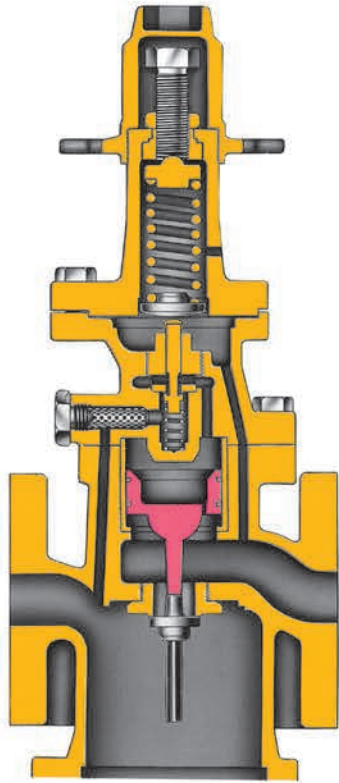

Three sub-units combine to form the reliable, accurate, cost-effective COSPECT

Reducing valves had remained essentially unchanged for decades—conventional designs seemed good enough. But manufacturers increasingly demanded more effective process control for improved product quality; TLV responded with this remarkable innovation.

With conventional pressure reducing valves, wide variations in primary pressure cause the secondary pressure to “drift”; this produces temperature variation, which results in inconsistent product quality. Also, valve hunting and vibration make it difficult to accurately set the precise system pressure needed. These valves are also subject to failure from the effects of rust, scale, and other impurities. In addition, conventional condensate separators do not efficiently remove condensate, reducing the productivity of steam equipment.

TLV applied its fluid control technology to solve these critical problems. The answer? The **COSPECT**—an innovative design with three unique features: **SAS**, **SCE** and **SST**.

1. SAS

Shock-Absorbing Spherical piston



2. SCE

Super Cyclonical Effects separator

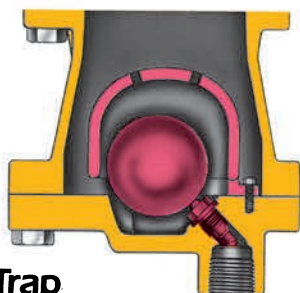

3. SST

Super Steam Trap

Construction

The three remarkable features—**SAS**, **SCE**, and **SST** combine into a single space-saving unit, which also simplifies system layout, piping, and maintenance. **COSPECT**. Three problem-solvers in one to increase productivity and improve product quality.

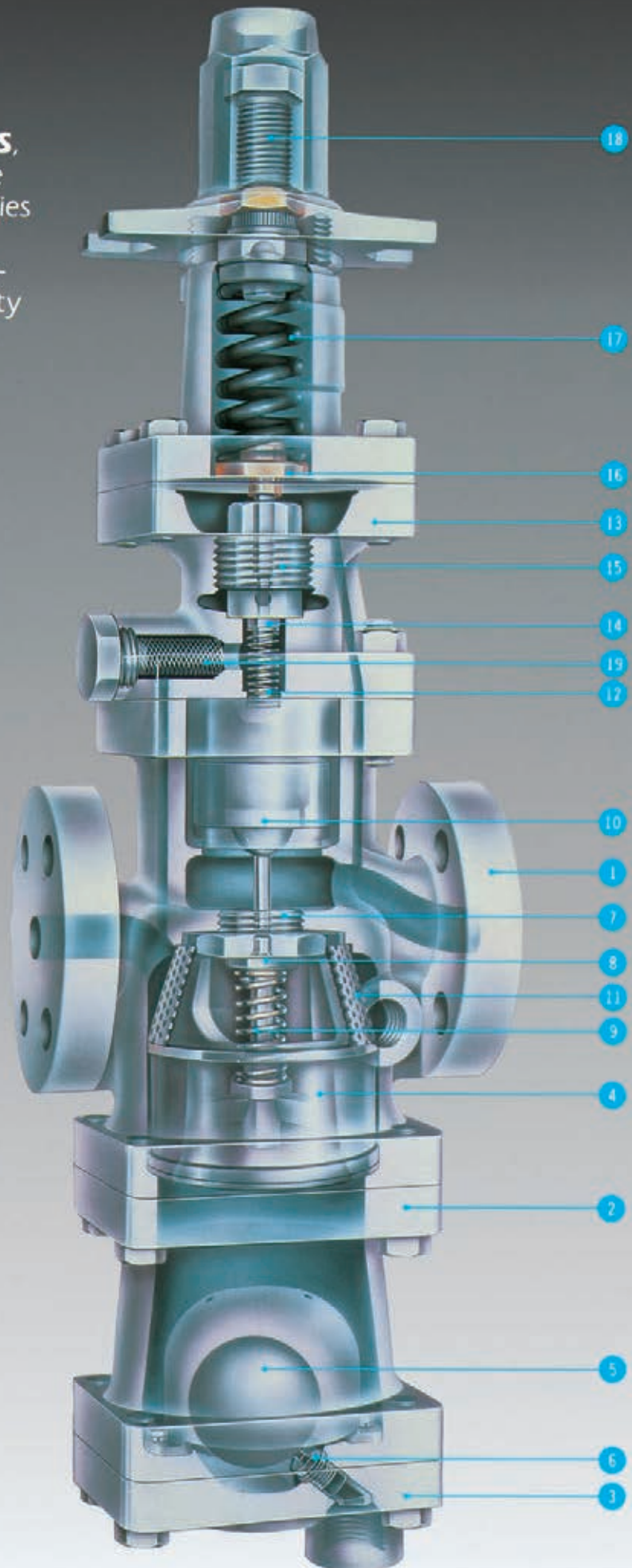

Part	Material
1 Main body	Cast iron or Ductile cast iron
2 Trap body	Cast iron or Ductile cast iron
3 Trap cover	Cast iron or Ductile cast iron
4 Separator	Stainless steel
5 Float	Stainless steel
6 Trap valve seat	Stainless steel
7 Main valve seat	Stainless steel
8 Main valve	Stainless steel
9 Main valve spring	Stainless steel
10 Piston	Stainless steel
11 Separator screen	Stainless steel
12 Pilot valve spring	Stainless steel
13 Pilot body	Ductile cast iron
14 Pilot valve	Stainless steel
15 Pilot valve seat	Stainless steel
16 Diaphragm	Stainless steel
17 Coil spring	Carbon steel
18 Adjustment screw	Cr-Mo steel
19 Pilot screen	Stainless steel

Three **COSPECT** Design Breakthroughs Provide Dry Saturated Steam at a Constant Pressure and Temperature.

1. SAS: Shock-Absorbing Spherical Piston

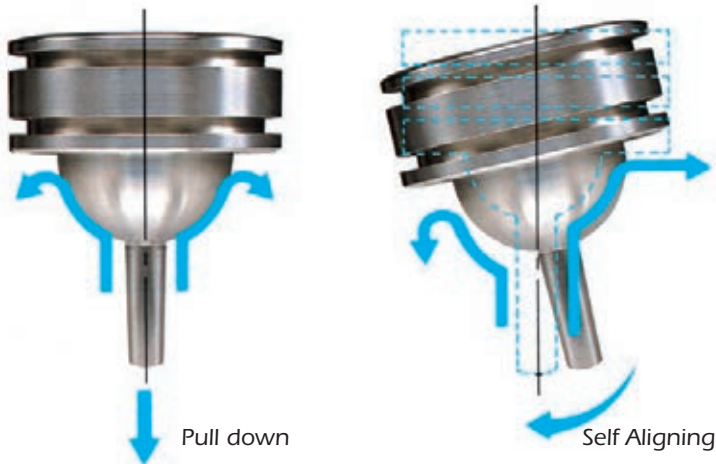

High Stability of Set Pressure

The spherical surface of this SAS piston creates a low pressure area in the passing steam flow. This pulls the piston down, making the orifice easy to open for accurate, responsive control. The piston is also self-centering when the valve stem tilts. As illustrated, steam flows slower through the shorter path on the left side than on the right side, creating a high pressure region on the left side and a low pressure region on the right side. This pressure difference causes the piston to self-align. The unique SAS design permits a smooth high velocity flow eliminating the turbulent steam flow characteristic of conventional valve designs.

2. SCE: Super Cyclonical Effects Separator



98% Separation Efficiency

This unique SCE separator provides dry saturated secondary steam by effectively removing condensate and scale with its 98% separation efficiency, thus improving steam equipment productivity due to greater heat transfer. The pressure reducing valve service life is extended since the effective removal of condensate and scale protects the main valve from erosion.

3. SST: Super Steam Trap

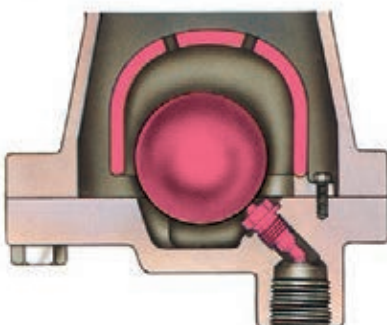

Continuous Discharge and Seal-tight Shut-off

Separated condensate is instantly removed by this SST continuous discharge trap. The unique three-point seating design and precision ground spherical float provides seal-tight shut-off even under no-load conditions.

Glossary

Primary pressure: Steam pressure at the inlet of the pressure regulator.

Secondary pressure: Steam pressure at the outlet of the pressure regulator.

Minimum adjustable flow rate: Minimum flow that can be maintained at a constant pressure level.

Set pressure: Desired secondary pressure.

Rated flow rate: Maximum flow rate, at secondary pressure, that can be obtained within a given offset when the primary pressure is held constant.

Pressure rise: The increase in set pressure, following steam-using equipment shutdown by closing the inlet valve to the equipment.

Offset: Difference between actual secondary pressure and set pressure, when flow rate is increased from the minimum adjustable flow rate to the rated flow rate while primary pressure is held constant.

Pressure Rise Following Equipment Shutdown

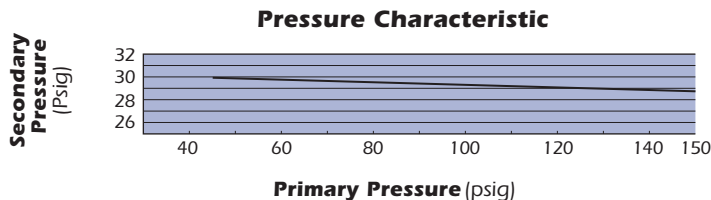
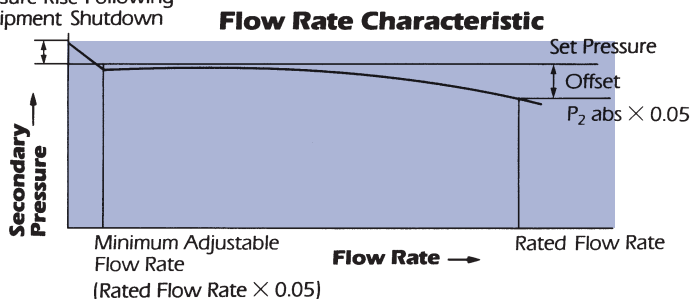

Pressure vs. Flow Rate

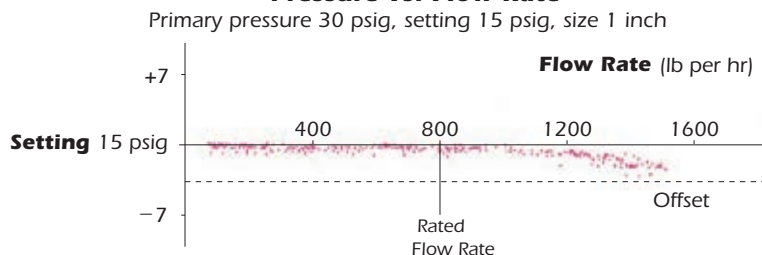

Above: The pressure and flow characteristic data prove stable valve performance: accurate pressure reduction is maintained even if flow varies. This test data was obtained by computer-controlled automated testing equipment.

Left: After setting the secondary pressure of 30 psig when the primary pressure is 45 psig the chart illustrates the variation of the secondary pressure when the primary pressure is increased to 150 psig.

Steam Flow Velocity vs. Separation Rate

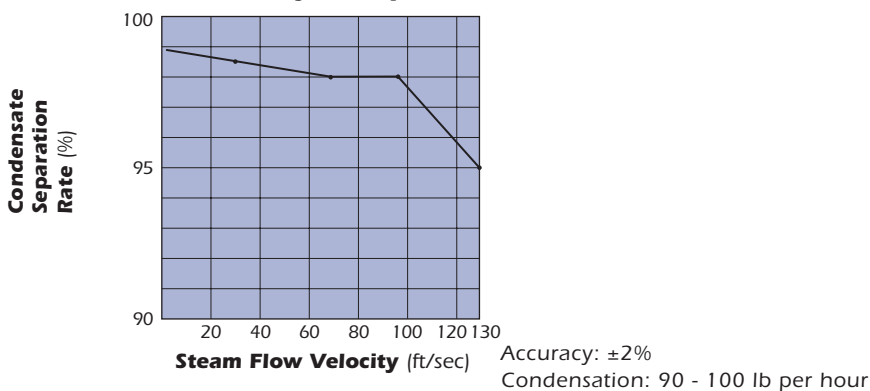

This test data demonstrates that the SCE separator provides the exceptionally high condensate separation rate of 98.5% at a steam flow velocity of 33 ft/sec.

Separation rate (%) is given as:

$$\frac{\text{quantity of condensate discharged}}{\text{quantity of incoming condensate}} \times 100$$

.....This combined with the pressure reducing function of the valve, delivers virtually 100% dry steam downstream.

Condensate Discharge Capacities

Model COS-3

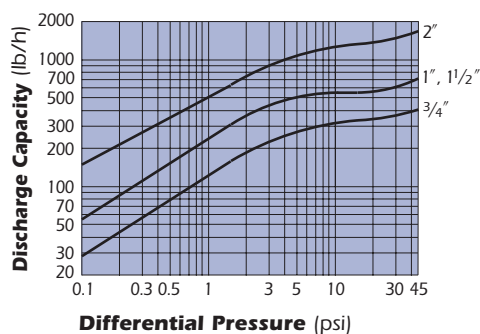

Model COS-16

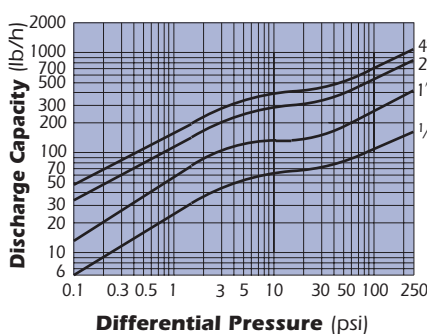

Model COS-21

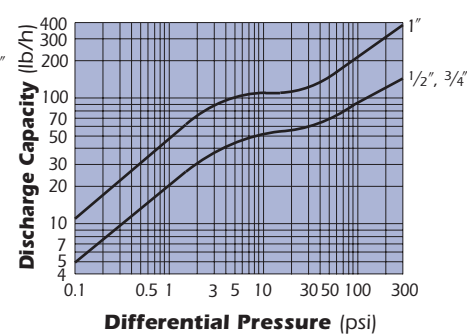

This discharge capacity chart shows maximum hourly discharge rates of condensate 11°F below saturated steam temperature. The pressure differential is the difference between the trap primary and secondary pressures.

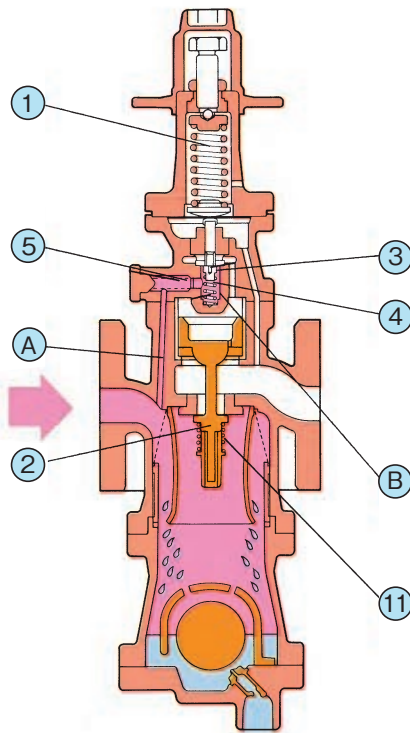

1

Until upper coil spring ① is compressed, main valve ② and pilot valve ③ are held closed by main valve spring ⑪ and pilot valve spring ④. Steam enters through passage A, passes through pilot screen ⑤ and enters pilot chamber B.

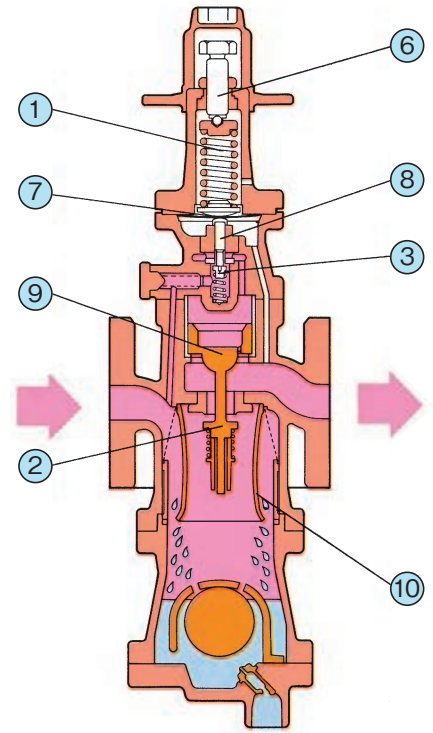

Standard Specifications

Model	COS-3		COS-16		COS-21
Body Material	Cast Iron		Cast Iron		Ductile Cast Iron
Connection	Screwed	Flanged	Screwed	Flanged	Screwed
Size (in)	3/4, 1	1, 1 1/2, 2	1/2, 3/4, 1	1, 1 1/2, 2, 2 1/2, 3, 4	1/2, 3/4, 1
Maximum Operating Pressure (psig) PMO	45		250		300
Maximum Operating Temperature (°F) TMO	428		428		428
Maximum Allowable Pressure (psig) PMA	250		250		300
Maximum Allowable Temperature (°F) TMA	428		428		428
Primary Pressure Range (psig)	15 to 45		30 to 250		190 to 300
Adjustable Differential Pressure (psi)	—		10 to 120		30 to 120
Pressure Adjustment Range (psig)	1.5 to 7		5 to 210		80 to 252
Maximum Adjustable Secondary Pressure (psig)	7		84% of primary pressure (or primary pressure minus 10 psi, whichever is lower)		84% of primary pressure
Minimum Adjustable Secondary Pressure (psig)	1.5		10% of primary pressure (or primary pressure minus 120 psi, whichever is higher) (except primary pressures up through 85, that are 5 psig)		80 psig (or primary pressure minus 120 psi, whichever is higher)
Minimum Adjustable Flow Rate	5% of rated flow rate (sizes 1/2" to 2"); 10% of rated flow rate (sizes 3" to 4")				
Accuracy of Regulation (psi) AOR	± 1 (under steady flow conditions)				
Seat Leakage Rating	Less than 0.1% of rated flow rate				

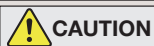

CAUTION

To avoid abnormal operation, accidents or serious injury, DO NOT use this product outside of the specification range. Local regulations may restrict the use of this product to below the conditions quoted.

Dimensions

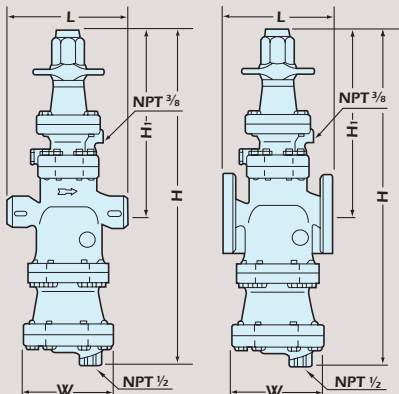

Size (in)	L (in)			H	H ₁	W	Weight (lb) **	
	Screwed NPT	Connects to ASME Class						
		125FF	250RF					
COS-3/COS-16	1/2*	—	—	19 1/2	11 1/4	4 1/8	(32)	
	3/4	6 7/8	—				(33)	
	1	7 1/2	6 15/16	7 3/8	20 9/16	11 7/8	5 7/8	46(44)
	1 1/2	—	8 1/4	8 3/4	22 1/2	11 7/8	6 1/2	60
	2	—	10	10 1/4	25	12 3/8	7 1/2	95
	2 1/2	—	14 1/4	14 13/16	34 1/4	16 1/8	11	152
COS-21	3*	—	14 3/8	15 1/16	34 1/4	16 1/8	11	159
	4*	—	17 1/16	17 11/16	40 7/16	17 5/8	13 3/4	231
	1/2	—	—	—	20 1/4	12	4 7/8	(33)
	3/4	6 7/8	—	—				(35)
	1	7 1/2	—	—	21 5/16	11 7/8	5 7/8	(44)

Other standards available, but length and weight may vary

* COS-16 only ** Weight is for Class 250 RF, () for NPT

2

When secondary pressure is set by tightening adjustment screw ⑥, upper coil spring ① is compressed and diaphragm ⑦ flexes, forcing pilot guide ⑧ to open pilot valve ③. Steam enters chamber above piston ⑨, forcing it down. Main valve ② opens the orifice, providing steam to the secondary side. Before entering the main valve, steam passes through the separator ⑩. The angled separator blades cause the steam to whirl and release the entrained condensate, which is discharged continuously through the steam trap.

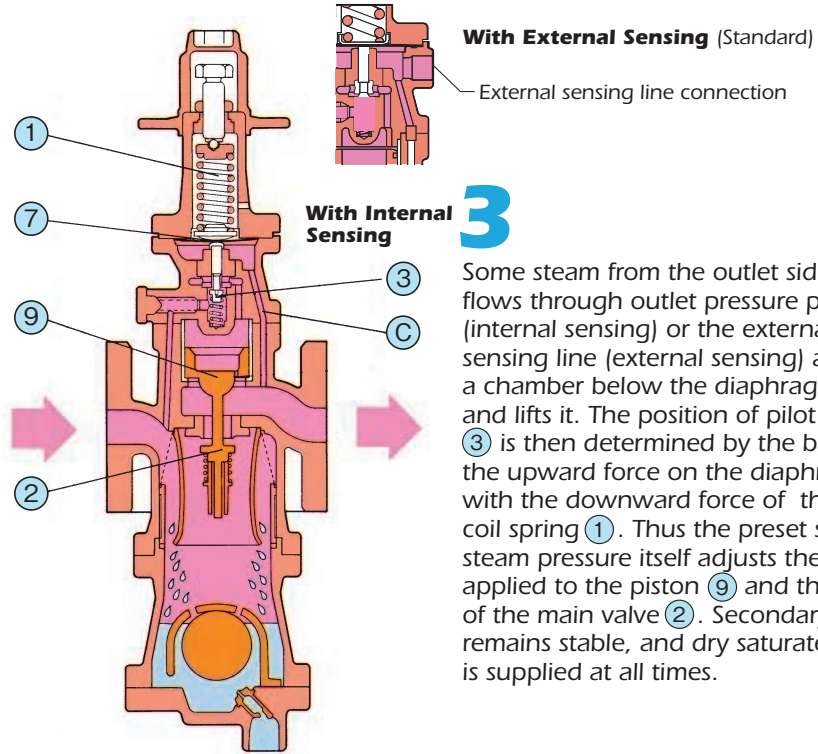

3

Some steam from the outlet side flows through outlet pressure passage ④ (internal sensing) or the external sensing line (external sensing) and enters a chamber below the diaphragm ⑦, and lifts it. The position of pilot valve ③ is then determined by the balance of the upward force on the diaphragm with the downward force of the upper coil spring ①. Thus the preset secondary steam pressure itself adjusts the force applied to the piston ⑨ and the opening of the main valve ②. Secondary pressure remains stable, and dry saturated steam is supplied at all times.

Specifications For Other COS Series Pressure Reducing Valves

Model	A-COS-10		V-COS
Application	Air		Vacuum Pressure Steam
Body Material	Cast Iron		
Connection	Screwed	Flanged	Flanged
Size (in)	1/2, 3/4, 1	1, 1 1/2, 2	1, 1 1/2, 2
Maximum Operating Pressure (psig) PMO	125		30
Maximum Operating Temperature (°F) TMO	212		302
Maximum Allowable Pressure (psig) PMA	250		30
Maximum Allowable Temperature (°F) TMA	428		302
Primary Pressure Range (psig)	15 to 125		15 to 30
Adjustable Pressure Range (psig)	7 to 100		-12 to 12
Minimum Differential Pressure (psi)	7		—
Minimum Adjustable Flow Rate	10% of rated flow rate		
Accuracy of Regulation (psi) AOR	± 1.5% (under steady flow conditions)		
Seat Leakage Rating	—		Less than 0.1% of rated flow rate

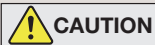

To avoid abnormal operation, accidents or serious injury, DO NOT use this product outside of the specification range. Local regulations may restrict the use of this product to below the conditions quoted.

Dimensions

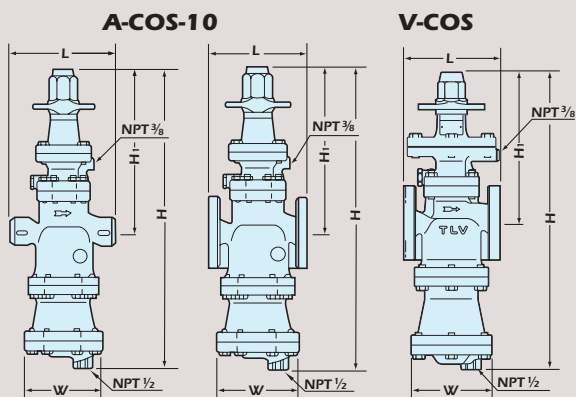

A-COS-10 Screwed*

Size (in)	L	H	H ₁	W	Weight (lb)
1/2	6 7/8	19 1/2	11 1/4	4 1/8	32
3/4					33
1	7 1/2	20 9/16	11 1/8	5 7/8	44

* NPT, other standards available

A-COS-10/V-COS Flanged

Size (in)	L Connects to ASME Class		H	H ₁	W	Weight (lb)*	
	125FF	250RF					
A-COS-10	1	6 5/16	7 3/8	20 9/16	11 1/8	5 7/8	42
	1 1/2	8 1/4	8 3/4	22 1/2	11 7/8	6 1/2	55
	2	10	10 1/4	25	12 3/8	7 1/2	88
V-COS	1	6 5/16	7 3/8	22 7/8	13 3/8	5 7/8	55
	1 1/2	8 1/4	8 3/4	24 13/16	14 3/16	6 1/2	66
	2	10	10 1/4	27 1/4	14 5/8	7 1/2	99

Other standards available, but length and weight may vary

* Weight is for Class 125 FF



DO NOT DISASSEMBLE OR REMOVE THIS PRODUCT WHILE IT IS UNDER PRESSURE. Allow internal pressure of this product to equal atmospheric pressure and its surface to cool to room temperature before disassembling or removing. Failure to do so could cause burns or other injury. READ INSTRUCTION MANUAL CAREFULLY.

TLV CORPORATION

13901 South Lakes Drive, Charlotte, NC 28273-6790

Tel: 704-597-9070 Fax: 704-583-1610

E-mail: tlv@tlvengineering.com <https://www.tlv.com>

For Technical Service 1-800 "TLV TRAP"



Manufacturer

TLV CO., LTD.

Kakogawa, Japan

is approved by LRQA Ltd. to ISO 9001/14001

ISO 9001
ISO 14001

