



PowerTrap[®]

MODEL GP14-B

MECHANICAL PUMP FOR CONDENSATE REMOVAL AND RECOVERY

Benefits

Pump for a wide range of applications. Ideal for condensate removal from vented receivers and sump drainage.

1. Handles high-temperature condensate without cavitation.
2. No electric power or additional level controls required, hence **INTRINSICALLY SAFE**.
3. Pump will operate with a low filling head.
4. Durable nickel-based alloy compression coil spring.
5. Easy, inline access to internal parts simplifies cleaning and reduces maintenance costs.
6. High-quality stainless steel internals and hardened working surfaces ensure reliability.
7. Cycle Counter installable as option.



Specifications

Model		GP14-B		
Body Material		Cast Iron	Cast Steel	
Connection	Pumped Medium Inlet & Outlet	Screwed	Screwed	Flanged
	Motive Medium & Pump Exhaust	Screwed	Screwed	Flanged
Size (in)	Pumped Medium: Inlet x Outlet	3 x 2		3 x 2
	Motive Medium Inlet	1		
	Pump Exhaust Outlet	1		
Maximum Operating Pressure (psig)	PMO	200		
Maximum Operating Temperature (°F)	TMO	392		
Maximum Allowable Pressure (psig)	PMA	Cast Iron: 200 Cast Steel: 230		
Maximum Allowable Temperature (°F)	TMA	428		
Motive Medium Pressure Range (psig)		100 to 200		
Maximum Allowable Back Pressure		7 psi less than motive medium pressure used, but not to exceed 115 psi		
Volume of Each Discharge Cycle (gal)		Approx. 8		
Motive Medium*		Saturated Steam, Compressed Air, Nitrogen		
Pumped Medium**		Steam Condensate, Water		

* Do not use with toxic, flammable or otherwise hazardous fluids.

Connections and sizes in bold are standard

** Do not use for fluids with specific gravities under 0.85 or over 1, or for toxic, flammable or otherwise hazardous fluids.



To avoid abnormal operation, accidents or serious injury, DO NOT use this product outside of the specification range. Local regulations may restrict the use of this product to below the conditions quoted.

No.	Description	Material	ASTM/AISI*	JIS	
①	Body	Cast Iron	A126 Cl.B	FC250	
		Cast Steel**	A216 Gr.WCB	—	
②	Cover	Cast Iron	A126 Cl.B	FC250	
		Cast Steel**	A216 Gr.WCB	—	
③	Cover Gasket	Graphite/Stainless Stl.	—/AISI316L	—/SUS316L	
④	Float	Stainless Steel	AISI316L/303	SUS316L/303	
⑤	Lever Unit	Stainless Steel	—	—	
⑥	Snap-action Unit	Stainless Steel	—	—	
⑦	Motive Medium Intake Valve Unit	Intake Valve	Stainless Steel	AISI303/440C	SUS303/440C
		Valve Seat	Cast Stainless Steel/ Stainless Steel	A351 Gr.CF8/ AISI440C	—/ SUS440C
⑧	Exhaust Valve Unit	Exhaust Valve	Stainless Steel	AISI420	SUS420J2
		Valve Seat	Stainless Steel	A567 630	SUS630
⑨	Check Valve***	CK3MG	Cast Stainless Steel	A351 Gr.CF8	—
		CKF3MG	Cast Stainless Steel	A351 Gr.CF8	—

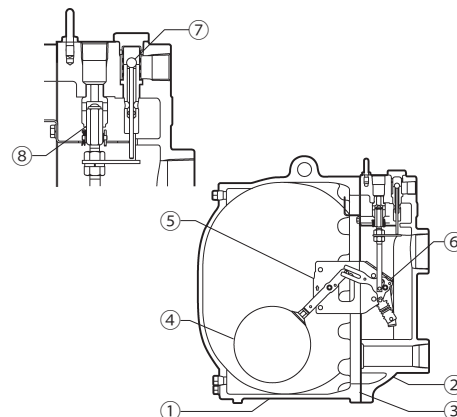

* Equivalent ** Option: Cast Stainless Steel

*** Not shown, model depends on GP14-B connection: CK3MG for screwed, CKF3MG for flanged

Dimensions

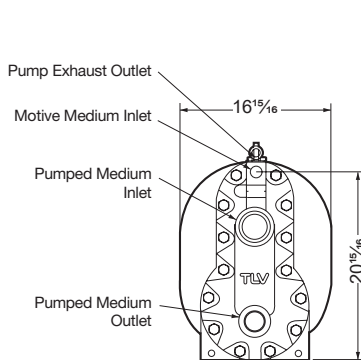

Units: in
Note: All Plug Holes NPT $\frac{1}{2}$

• Screwed*

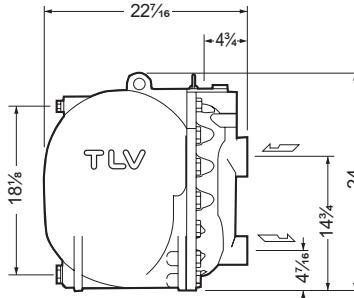

Weight (lb): 273 (Cast Iron), 300 (Cast Steel)
* NPT, other standards available

• Flanged**

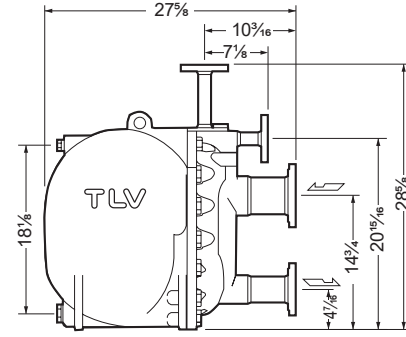

Weight (lb): 322 (Cast Steel)
** ASME Class 300 RF, other standards available

Discharge Capacity

Filling Head: 36" from Grade

Inlet Pipe Size		3"		3"	
Inlet Check Valve		3" CK3MG		3" CKF3MG	
Outlet Check Valve		2" CK3MG		2" CKF3MG	
Motive Medium		Air	Steam	Air	Steam
Motive Medium Inlet Press. (P _m) (psig)	Total Lift or Back Press. (P ₂) (psig)	(lb/h)	(lb/h)	(lb/h)	(lb/h)
200	25	13780	17200	14290	16080
	40	12760	14550	12980	14030
	60	11890	12120	12210	12120
	80	10800	9640	11020	10070
	100	9870	7790	10010	8470
175	150	8090	4860	8090	5790
	25	13660	16590	14190	15640
	40	12540	13930	12760	13540
	60	11710	11520	11960	11570
	80	10590	9080	10710	9500
150	100	9640	7270	9650	7890
	150	7830	4460	7660	5250
	15	14300	17270	15180	16550
	25	13470	15500	13950	15070
	40	12320	13000	12100	12890
125	60	11360	10730	11660	10870
	80	10170	8430	10370	8790
	100	9170	6740	9300	7200
	15	14300	16390	14960	15400
	25	13440	14650	13820	13590
100	40	12210	12220	12100	11230
	60	11150	9970	11190	9110
	80	10030	7680	11130	7140
	100	8750	6020	8690	5570
	15	14300	15350	14740	14620
75	25	13150	13060	13560	12680
	40	11650	10430	11900	10220
	60	10250	8090	10360	8020
	80	8860	6270	8910	5880
	15	14190	14030	14520	13130
50	25	12510	11220	13120	10930
	40	10640	8170	11140	8150
	60	8900	5990	9150	5820
	10	14270	13370	14810	12740
	15	13970	11990	13970	11520
25	25	11730	9210	12160	8930
	40	9460	6100	9780	5950
	5	14030	13200	14260	12030
25	10	13130	11470	12920	10750
	15	12400	9350	11400	7180

• Correction Factor

For GP14-B installed with filling heads other than 36"

Filling Head from Grade	Inlet Pipe / Check Valve Size (in)	
	3" CKF3MG	
60"	1.14	
54"	1.12	
48"	1.09	
42"	1.05	
36"	1.00	
30"	0.88	

• Illustration of Filling Head and Pressures

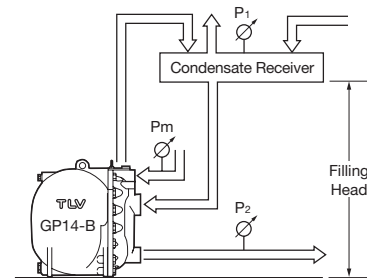

The discharge capacity is determined by the motive medium, motive medium pressure (P_m) and back pressure (P₂).

Make sure that:
Discharge Capacity × Correction Factor > Required Flow Rate

NOTE:

- A check valve must be installed at both the pumped medium inlet and outlet. To achieve the above capacities with the standard GP14-B configuration, TLV CK3MG or CKF3MG check valves must be used.
- Motive steam pressure minus back pressure must be greater than 7 psi.
- In closed system applications, the motive medium must be compatible with the liquid being pumped. If a non-condensable gas such as air or nitrogen is used as the motive medium, consult TLV for assistance.
- A strainer must be installed at the motive medium and pumped medium inlets.

Size of Receiver/Reservoir

The receiver/reservoir must have a capacity sufficient to store the condensate produced during the PowerTrap operation and discharge. A receiver will generally be larger than a reservoir because it must handle the condensate both as a liquid and as flash steam, and separate one from the other so that only condensate is sent to the PowerTrap.

If NO flash steam is present, use dimensions given in table 2. If flash steam is present, compare tables 1. and 2. and choose the larger resultant size. For all open systems, use table 1. to select a suitable vent pipe diameter.

1. Size of Receiver; flash steam is involved (Length: 3.5 ft)

Flash Steam up to lb/h	Receiver Diameter in	Vent Pipe Diameter in
50	3	1
75	4	1½
100	4	2
200	6	2½
300	8	3
400	8	4
600	10	4
800	12	6
1,000	14	6
1,400	16	8
1,600	18	8
2,000	20	8

2. Size of Reservoir; flash steam is not involved

Amount of Condensate (lb/h)	Reservoir Diameter (in) and Length (ft)						
	1½	2	3	4	6	8	10
500 or less	3.0 ft	2.0					
700	4.0	2.5	1.0				
1,000	5.5	3.5	1.5				
1,200		4.5	2.0	1.0			
1,500			2.5	1.5			
2,000			3.5	2.0			
3,000			4.5	3.0			
4,000			6.5	4.0	1.5		
5,000				5.0	2.5		
6,000				5.5	2.5	1.5	
7,000				6.5	3.0	1.5	
8,000					3.5	2.0	
9,000					4.0	2.5	1.5
10,000					4.5	2.5	1.5
12,000					5.0	3.0	2.0
14,000					6.0	3.5	2.5
16,000					6.5	4.0	2.5
18,000						4.5	3.0
20,000						5.0	3.5

Reservoir length can be reduced by 50% when the motive medium pressure (Pm) divided by back pressure (P2) equals 2 or greater (when $P_m \div P_2 \geq 2$).

Steam or Air Consumption (Motive Medium)

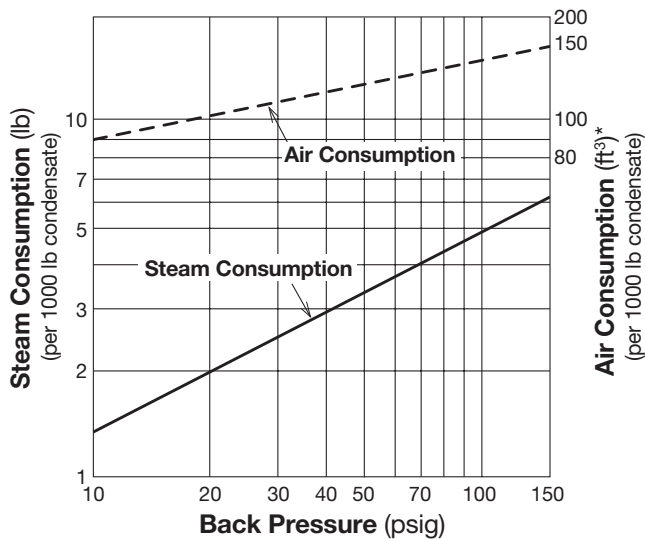

* Equivalent consumption of air at 68 °F under atmospheric pressure

Cycle Counter (Option)

Two types of counter can be installed on the GP14-B to monitor the number of pumping cycles and help to determine the timing of maintenance, or estimate the volume of pumped condensate.

- C1CM (Counter Unit Type):
Self-contained standalone unit. Includes an LCD counter display and an operation indicator LED.
- C1SM (Terminal Box Type):
Designed for use with remote monitoring equipment and systems.

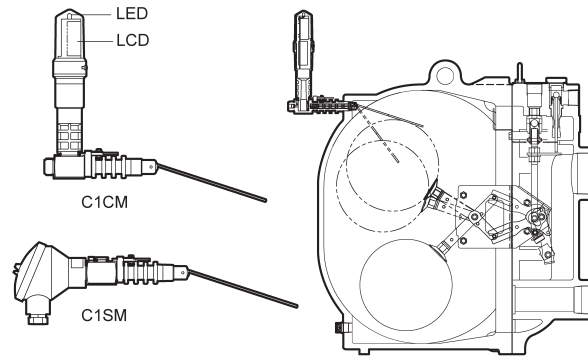

Intrinsically safe models are also available.
See the Cycle Counter SDS for further details.

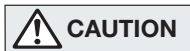

CAUTION DO NOT DISASSEMBLE OR REMOVE THIS PRODUCT WHILE IT IS UNDER PRESSURE. Allow internal pressure of this product to equal atmospheric pressure and its surface to cool to room temperature before disassembling or removing. Failure to do so could cause burns or other injury. READ INSTRUCTION MANUAL CAREFULLY.

TLV CORPORATION

13901 South Lakes Drive, Charlotte, NC 28273-6790
Tel: 704-597-9070 Fax: 704-583-1610
E-mail: tlv@tlvengineering.com <https://www.tlv.com>
For Technical Service 1-800 "TLV TRAP"



Manufacturer
TLV CO., LTD.
Kakogawa, Japan
is approved by LRQA Ltd. to ISO 9001/14001

ISO 9001
ISO 14001

