



FREE FLOAT[®] STEAM TRAP

MODEL SH6NL/SH6NH

HIGH-PRESSURE FREE FLOAT STEAM TRAP WITH THREE-POINT SEATING AND THERMOSTATIC AIR VENTING

Benefits

Inline repairable trap with tight shut-off for drainage of superheated or high-pressure steam mains, equipment, and turbines.

1. Self-modulating free float provides continuous, smooth, low-velocity condensate discharge.
2. Constant water seal and unique rotational seating design prevents concentrated wear to ensure long life.
3. Three-point seating ensures steam-tight seal, even under no-load conditions.
4. Easy, inline access to internal parts to simplify cleaning and lower maintenance costs.
5. Rugged float construction with up to 1600 or 2300 psig* hydraulic shock rating ensures excellent resistance to water hammer.
6. Durable thermostatic air vent for exceptionally fast start-up.
7. Built-in screen for extended trouble-free service.

* Depending on orifice no.

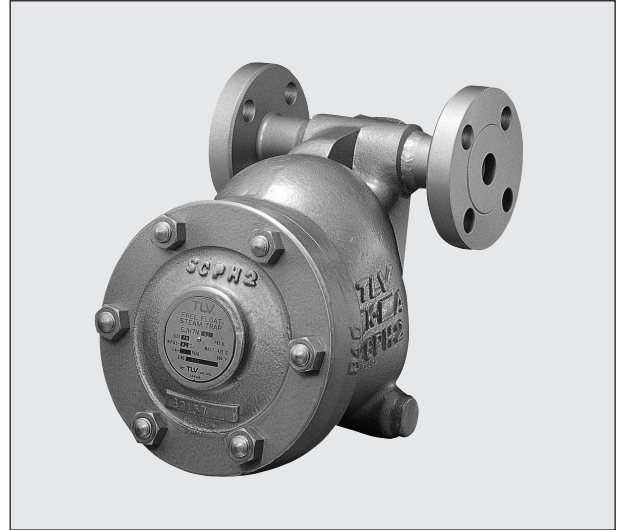

Specifications

Model	SH6NL		SH6NH
Connection	Socket Weld	Flanged	Socket Weld
Size (in)	1	1	3/4, 1
Orifice No.	46, 65		100
Maximum Operating Pressure (psig) PMO	650, 925		1500
Maximum Differential Pressure (psi) ΔPMX	650, 925		1500
Minimum Operating Pressure (psig)	1.5		1.5
Maximum Operating Temperature (°F) TMO	800		800
Maximum Allowable Pressure (psig) PMA	925		1500
Maximum Allowable Temperature (°F) TMA	800		800

CAUTION To avoid abnormal operation, accidents or serious injury, DO NOT use this product outside of the specification range. Local regulations may restrict the use of this product to below the conditions quoted.

Connections and sizes in bold are standard

No.	Description	Material	ASTM/AISI*	JIS
①	Body	Cast Steel	A216 Gr.WCB	—
②	Cover	Cast Steel	A216 Gr.WCB	—
③ ^{MR}	Cover Gasket	SH6NL Graphite/Stainless Steel SH6NH Graphite/Stainless Steel	- /AISI316L - /AISI304	- /SUS316L - /SUS304
④ ^F	Float	Stainless Steel	AISI316L	SUS316L
⑤ ^R	Orifice	—	—	—
⑥ ^{MR}	Orifice Gasket	SH6NL Graphite/Stainless Steel SH6NH Graphite/Stainless Steel	- /AISI316L - /AISI316	- /SUS316L - /SUS316
⑦ ^R	Air Vent Strip	Bimetal	—	—
⑧ ^R	Screw & Spring Washer	Stainless Steel	AISI304	SUS304
⑨	Cover Bolt	Alloy Steel	A193 Gr.B7	SNB7
⑩	Cover Nut	Carbon Steel	AISI1045	S45C
⑪ ^R	Screen	Stainless Steel	AISI430	SUS430
⑫	Screen Holder	Cast Stainless Steel	A351 Gr.CF8	—
⑬ ^{MR}	Screen Holder Gasket	Soft Iron	AISI1010	SUYP
⑭	Orifice Plug	Cast Stainless Steel	A351 Gr.CF8	—
⑮ ^{MR}	Orifice Plug Gasket	Soft Iron	AISI1010	SUYP
⑯	Flange	Carbon/Cast Steel***	A105/216 Gr.WCB	—
⑰	Socket**	Carbon Steel	A105	—
⑱	Nameplate	Stainless Steel	AISI304	SUS304

* Equivalent ** Not shown *** Material depends on flange specifications
Replacement kits available: (M) maintenance parts, (R) replacement parts, (F) float

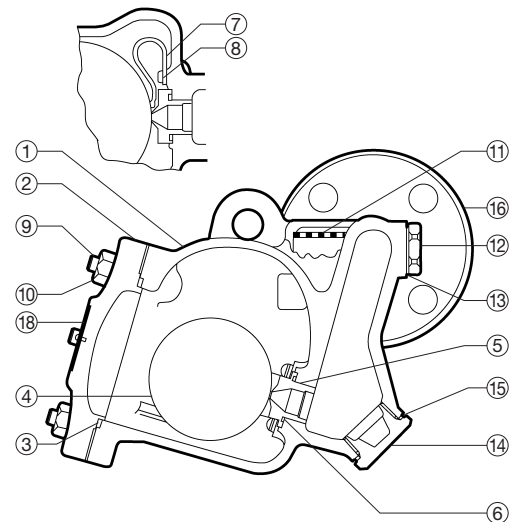

Dimensions

● **SH6NL/SH6NH** Socket Weld

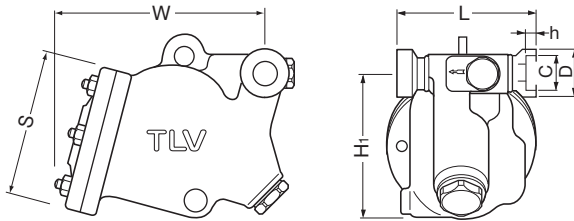

SH6NL/SH6NH Socket Weld* (in)

Model	Size	L	H1**	W**	φ S	φ D	φ C	h	Weight (lb)
SH6NL	1	7	7 ⁵ / ₁₆	10 ¹ / ₄	7 ¹ / ₁₆	2	1.330	9 ¹ / ₁₆	46
SH6NH	3/4	7	7 ¹ / ₂	11 ⁵ / ₈	8 ¹ / ₁₆	1 ³ / ₄	1.065	9 ¹ / ₁₆	66
	2 ¹ / ₁₆					68			

* ASME B16.11-2005, other standards available
 ** Approx.

● **SH6NL** Flanged

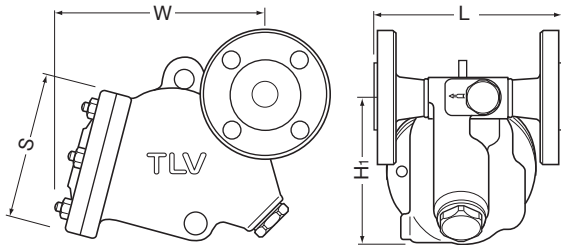

SH6NL Flanged (in)

Model	Size	L			H1*	W*	φ S	Weight** (lb)
		Connects to ASME Class	150RF	300RF				
SH6NL	1	8 ³ / ₄	8 ³ / ₄	8 ³ / ₄	7 ⁵ / ₁₆	10 ¹ / ₄	7 ¹ / ₁₆	51

Other standards available, but length and weight may vary
 * Approx.
 ** Weight is for Class 600RF

Discharge Capacity

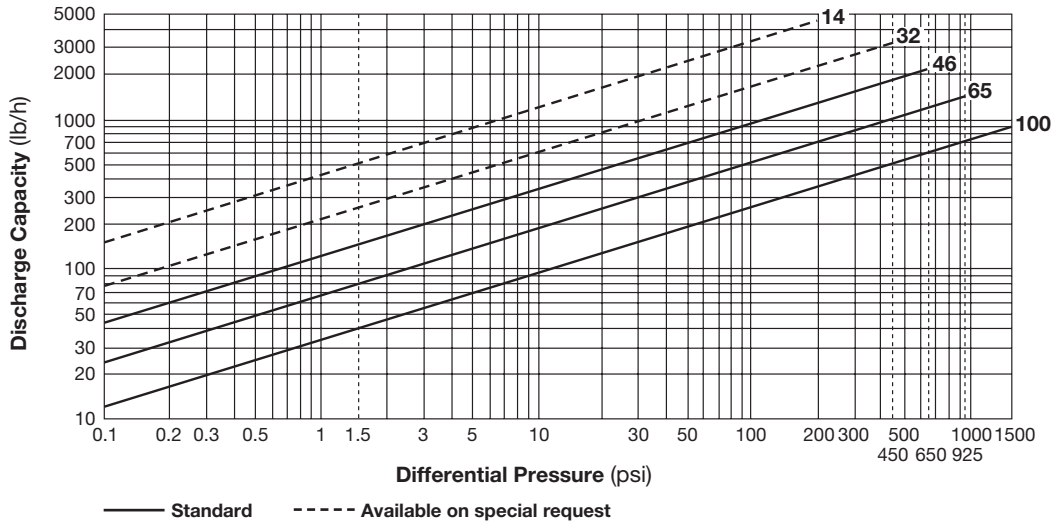

- 1. Line numbers within the graph refer to orifice numbers.
- 2. Differential pressure is the difference between the inlet and outlet pressure of the trap.
- 3. Capacities are based on continuous discharge of condensate 11 °F below saturated steam temperature.
- 4. Recommended safety factor: at least 1.5.

CAUTION DO NOT use this product under conditions that exceed maximum differential pressure, as condensate backup will occur!

CAUTION DO NOT DISASSEMBLE OR REMOVE THIS PRODUCT WHILE IT IS UNDER PRESSURE. Allow internal pressure of this product to equal atmospheric pressure and its surface to cool to room temperature before disassembling or removing. Failure to do so could cause burns or other injury. READ INSTRUCTION MANUAL CAREFULLY.

TLV CORPORATION

13901 South Lakes Drive, Charlotte, NC 28273-6790
 Tel: 704-597-9070 Fax: 704-583-1610
 E-mail: tlv@tlvengineering.com <https://www.tlv.com>
 For Technical Service 1-800 "TLV TRAP"



Manufacturer
TLV CO., LTD.
 Kakogawa, Japan
 is approved by LRQA Ltd. to ISO 9001/14001

