



FREE FLOAT[®] STEAM TRAP

MODELS SS1-M2/SS3

STAINLESS STEEL FREE FLOAT STEAM TRAPS WITH THREE-POINT SEATING AND THERMOSTATIC AIR VENTING

Benefits

Stainless steel traps with tight shut-off for drainage of superheated steam mains.

1. Free Float's unique rotational seating design eliminates concentrated wear to ensure long life.
2. Precision-ground float, three-point seating and constant water seal ensure steam-tight seal, even under no-load conditions.
3. Model SS1 allows easy, inline access to internal parts to simplify cleaning and lower maintenance costs. Model SS3 is maintenance-free: only one moving part in an all-welded steel case.
4. Float with up to 1740 psig hydraulic shock rating ensures excellent resistance to water hammer.
5. Durable thermostatic air vent automatically vents air for exceptional start-up and performance.
6. Extremely soft near-to-steam temperature discharge for safety and environmental considerations.
7. Built-in screen for extended trouble-free service.

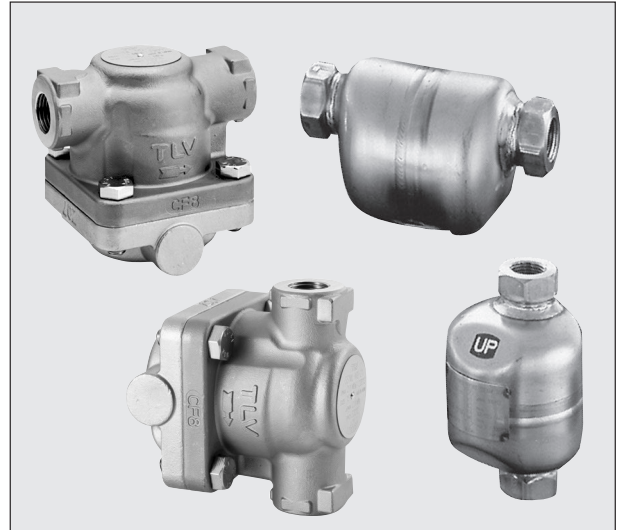

Specifications

Model	SS1VL-M2	SS1NL-M2	SS1VH-M2	SS1NH-M2	SS3V	SS3N
Installation	Vertical	Horizontal	Vertical	Horizontal	Vertical	Horizontal
Connection	Screwed / Socket Weld		S, SW		Screwed	Screwed / Flanged
Size (in)	1/2, 3/4, 1 / 1/2, 3/4, 1		1/2, 3/4, 1		1/2, 3/4, 1	1/2, 3/4, 1
Orifice No.	10, 18, 21				10, 18, 21	
Maximum Operating Pressure (psig) PMO	150, 250, 300				150, 250, 300	
Maximum Differential Pressure (psi) ΔPMX	150, 250, 300				150, 250, 300	
Minimum Operating Pressure (psig)	1.5				1.5	
Maximum Operating Temperature (°F) TMO	428		752		752	
Maximum Allowable Pressure (psig) PMA	300		350		345	
Maximum Allowable Temperature (°F) TMA	428		752		752	

CAUTION To avoid abnormal operation, accidents or serious injury, DO NOT use this product outside of the specification range. Local regulations may restrict the use of this product to below the conditions quoted.

Connections and sizes in bold are standard
S = Screwed, SW = Socket Weld

No.	Description	Material	ASTM/AISI*	JIS
①	Body (SS1-M2)	Cast Stainless Steel	A351/A351M Gr.CF8	—
	Body (SS3)	Stainless Steel	A240 Type 316L	—
②	Cover (SS1-M2)	Cast Stainless Steel	A351/A351M Gr.CF8	—
	Inner Cover (SS3)	Stainless Steel	A240 Type 316L	—
③ ^F	Float	Stainless Steel	AISI316L	SUS316L
④ ^R	Orifice	—	—	—
⑤ ^{MR}	Orifice Gasket (SS1-M2)	Stainless Steel	AISI316L	SUS316L
⑥ ^R	Screen	Stainless Steel	AISI304	SUS304
⑦ ^{MR}	Cover Gasket (SS1NL-M2)	Fluorine Resin	PTFE	PTFE
	Cover Gasket (SS1NH-M2)	Graphite/Stainl. Steel	-/AISI316L	-/SUS316L
⑧	Cover Bolt (SS1-M2)	Stainless Steel	—	—
⑨ ^R	Air Vent Strip	Bimetal	—	—
⑩ ^R	Screw (SS1-M2)	Stainless Steel	AISI304	SUS304
⑪ ^R	Spring Washer (SS1-M2)	Stainless Steel	AISI304	SUS304
⑫	Nameplate	Stainless Steel	AISI304	SUS304
⑬	Connector (SS1-M2)	Stainless Steel	AISI304	SUS304
⑭	Socket (SS3)	Stainless Steel	A351 Gr.CF8	—
⑮	Float Guide (SS3)	Cast Stainless Steel	A351 Gr.CF3M	—
⑯	Flange** (SS3)	Cast Stainless Steel	A351/A351M Gr.CF8	—

* Equivalent ** Shown on reverse

Replacement kits available for SS1: (M) maintenance parts, (R) repair parts, (F) float

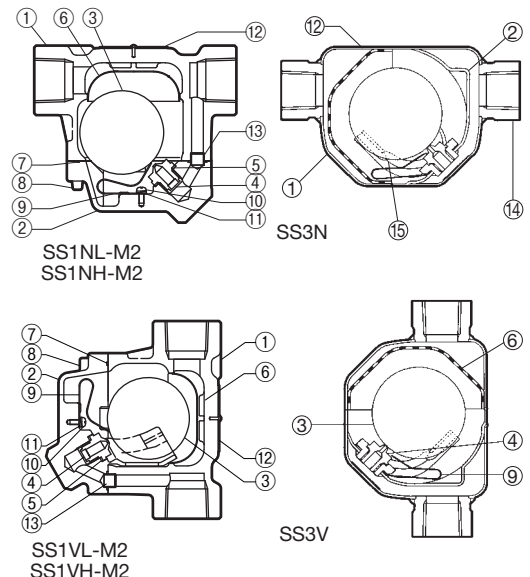

Copyright © TLV

Dimensions

● **SS1NL-M2/SS1NH-M2**

Screwed

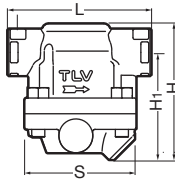

● **SS1VL-M2/SS1VH-M2**

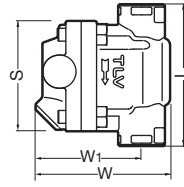

● **SS1NL-M2/SS1NH-M2**

Socket Weld

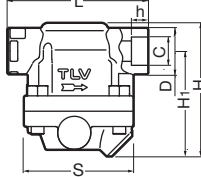

● **SS1VL-M2/SS1VH-M2**

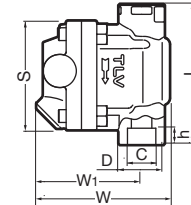

● **SS3N**

Screwed

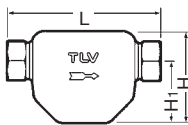

● **SS3V**



● **SS3N**

Flanged

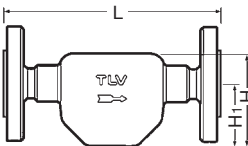

SS1N(V)L-M2/SS1N(V)H-M2 Screwed* (in)

Size	L	H/W**	H ₁ /W ₁ **	S	Weight (lb)
1/2	4 5/16	4 5/16	3 3/8	3 3/8	3.3
3/4	4 3/4				
1	5 1/8				3.7

* NPT, other standards available
** Approx.

SS1N(V)L-M2/SS1N(V)H-M2 Socket Weld* (in)

Size	L	H/W**	H ₁ /W ₁ **	S	φ D	φ C	h	Weight (lb)
1/2	4 5/16	4 5/16	3 3/8	3 3/8	1 5/16	0.855	1/2	3.3
3/4	4 3/4				1 9/16	1.065		
1	5 1/8				1 7/8	1.330		3.7

* ASME B16.11-2005, other standards available
** Approx.

SS3N/SS3V Screwed* (in)

Size	L	φ H/W	H ₁ /W ₁	Weight (lb)
1/2	5	3	2 1/16	1.8
3/4	6 1/16			2.2
1	6 1/2			2.6

* NPT, other standards available

SS3N Flanged (in)

Size	L		φ H	H ₁	Weight* (lb)
	Connects to ASME Class	300RF			
1/2	6 7/8	6 7/8	3	2 1/16	5.3
3/4	7 1/16	7 1/16			7.7
1	8 7/16	8 7/16			9.3

Other standards available, but length and weight may vary

* Weight is for Class 300 RF

Flange classes in bold are standard

Discharge Capacity

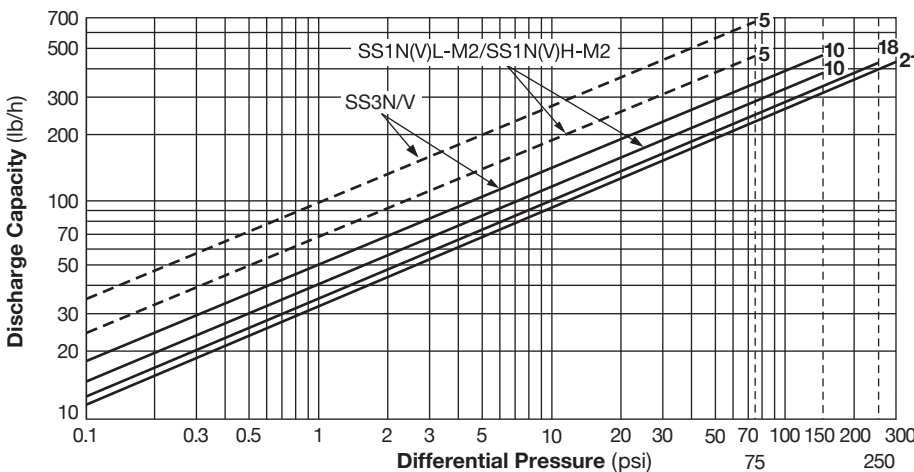

- Standard
 - - - Available on special request
1. Line numbers within the graph refer to orifice numbers.
 2. Differential pressure is the difference between the inlet and outlet pressure of the trap.
 3. Capacities are based on continuous discharge of condensate 11 °F below saturated steam temperature.
 4. Recommended safety factor: at least 1.5.



DO NOT use this product under conditions that exceed maximum differential pressure, as condensate backup will occur!



DO NOT DISASSEMBLE OR REMOVE THIS PRODUCT WHILE IT IS UNDER PRESSURE. Allow internal pressure of this product to equal atmospheric pressure and its surface to cool to room temperature before disassembling or removing. Failure to do so could cause burns or other injury. READ INSTRUCTION MANUAL CAREFULLY.

TLV CORPORATION

13901 South Lakes Drive, Charlotte, NC 28273-6790

Tel: 704-597-9070 Fax: 704-583-1610

E-mail: tlv@tlvengineering.com <https://www.tlv.com>

For Technical Service 1-800 "TLV TRAP"



Manufacturer

TLV CO., LTD.

Kakogawa, Japan

is approved by LRQA Ltd. to ISO 9001/14001

ISO 9001
ISO 14001

