



# PowerTrap®

## MODEL GP14L CAST IRON CAST STEEL

### COMPACT MECHANICAL PUMP FOR CONDENSATE REMOVAL AND RECOVERY

#### Features

**Pump for a wide range of applications. Ideal for low flow condensate removal from vented receivers situated at a low level.**

1. Handles high-temperature condensate without cavitation.
2. No electric power or additional level controls required, hence INTRINSICALLY SAFE.
3. Pump will operate with a low filling head (min. 300 mm).
4. Easy, inline access to internal parts simplifies cleaning and reduces maintenance costs.
5. High-quality stainless steel internals and hardened working surfaces ensure reliability.
6. Compact design permits installation in a limited space.
7. Cycle Counter installable as option.



#### Specifications

Model		GP14L	
Body Material		Cast Iron	Cast Steel
Connection	Pumped Medium Inlet & Outlet	Flanged*	
	Motive Medium & Pump Exhaust	Screwed	
Size	Pumped Medium: Inlet x Outlet	DN 40 x DN 25	
	Motive Medium Inlet	1/2"	
	Pump Exhaust Outlet	1/2"	
Maximum Operating Pressure (barg)	PMO	13	14
Maximum Operating Temperature (°C)	TMO	200	220
Motive Medium Pressure Range (barg)		0.3 – 13	0.3 – 14
Maximum Allowable Back Pressure		0.5 bar less than motive medium pressure used	
Volume of Each Discharge Cycle (ℓ)		Approx. 8.0	
Motive Medium**		Saturated Steam, Compressed Air, Nitrogen	
Pumped Medium***		Steam Condensate, Water	

\* For details of flange connection, see picture at bottom right. \*\* Do not use with toxic, flammable or otherwise hazardous fluids. 1 bar = 0.1 MPa  
 \*\*\* Do not use for fluids with specific gravities under 0.85 or over 1, or for toxic, flammable or otherwise hazardous fluids.

**PRESSURE SHELL DESIGN CONDITIONS (NOT OPERATING CONDITIONS):**  
 Maximum Allowable Pressure (barg) PMA: 13 (Cast Iron), 21 (Cast Steel)  
 Maximum Allowable Temperature (°C) TMA: 200 (Cast Iron), 260 (Cast Steel)



To avoid abnormal operation, accidents or serious injury, DO NOT use this product outside of the specification range. Local regulations may restrict the use of this product to below the conditions quoted.

No.	Description	Material	DIN*	ASTM/AISI*
①	Body	Cast Iron FC250	0.6025	A126 Cl.B
		Cast Steel** A216 Gr.WCB	1.0619	—
②	Cover	Cast Iron FC250	0.6025	A126 Cl.B
		Cast Steel** A216 Gr.WCB	1.0619	—
③	Cover Gasket	Graphite Compound	—	—
④	Float	Stainless Steel SUS316L	1.4404	AISI316L
⑤	Snap-action Unit	Stainless Steel	—	—
⑥	Motive Medium Inlet Valve Unit	Inlet Valve	Stainless Steel SUS440C	AISI440C
	Valve Seat	Stainless Steel SUS420F	1.4028	AISI420F
⑦	Exhaust Valve Unit	Exhaust Valve	Stainless Steel SUS440C	AISI440C
	Valve Seat	Stainless Steel SUS420F	1.4028	AISI420F
⑧	Inlet Check Valve CKF5M	Stainless Steel SUS304	1.4301	AISI304
⑨	Outlet Check Valve CKF3M	Cast Stainless Steel A351 Gr.CF8	1.4312	—

\* Equivalent materials \*\* Option: Cast Stainless Steel

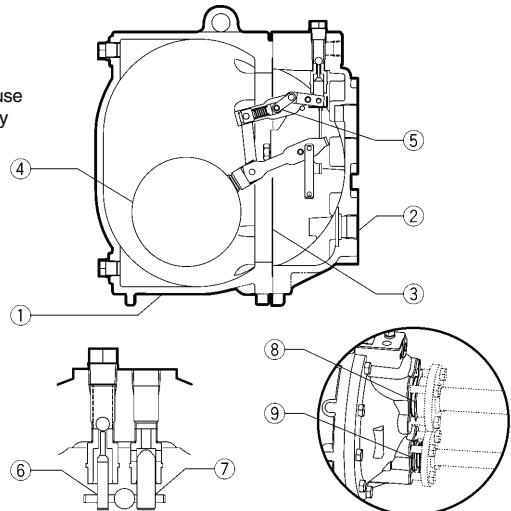

**Dimensions**

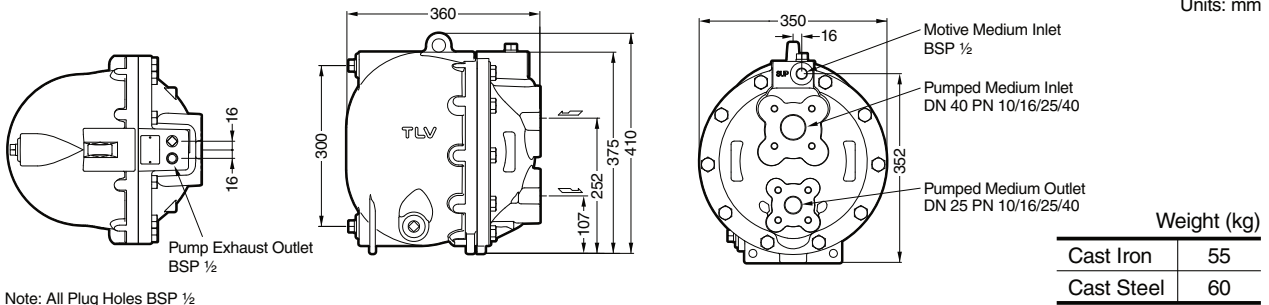

**Discharge Capacity**

Connection:	Flanged
Inlet size:	DN 40
Outlet size:	DN 25
Check Valve:	
Inlet (CKF5M):	DN 40
Outlet (CKF3M):	DN 25
Filling Head:	630 mm

- **Correction Factor**  
For GP14L installed with filling head other than 630 mm (minimum filling head: 300 mm)

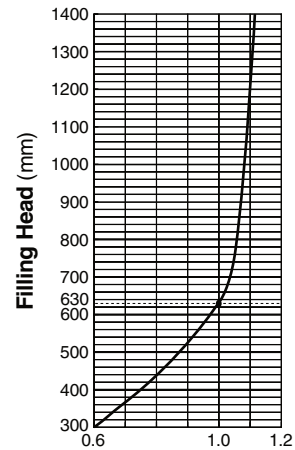
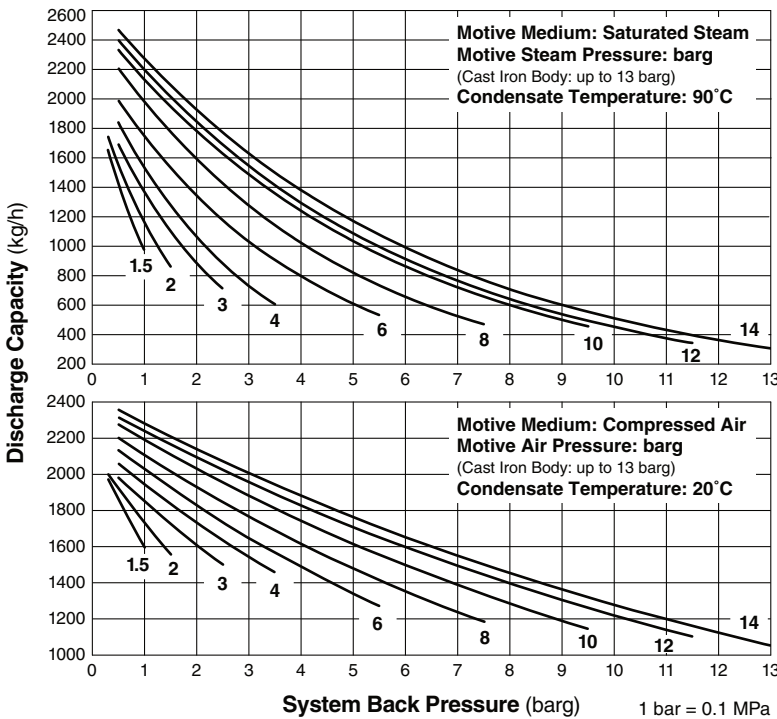

- **Illustration of Filling Head and Pressures**

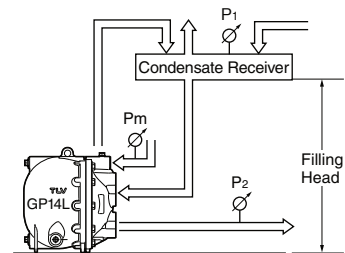

- NOTE:**
- A check valve must be installed at both the pumped medium inlet and outlet. To achieve the above capacities with the standard GP14L configuration, TLV check valves CKF5M for inlet and CKF3M for outlet must be used.
  - Motive steam pressure minus back pressure must be greater than 0.5 bar.
  - In closed system applications, the motive medium must be compatible with the liquid being pumped. If a non-condensable gas such as air or nitrogen is used as the motive medium, consult TLV for assistance.
  - A strainer must be installed at the motive medium and pumped medium inlets.

- The discharge capacity is determined by the motive medium, motive medium pressure (Pm) and back pressure (P2).

Make sure that:  
Discharge Capacity × Correction Factor > Required Flow Rate

## Size of Receiver/Reservoir

The receiver/reservoir must have a capacity sufficient to store the condensate produced during the **PowerTrap** operation and discharge. A receiver will generally be larger than a reservoir because it must handle the condensate both as a liquid and as flash steam, and separate one from the other so that only condensate is sent to the **PowerTrap**.

### ① Size of Reservoir; flash steam is involved (Length: 1 m)

Flash steam up to kg/h	Receiver diameter mm	Vent pipe diameter mm
25	80	25
50	100	50
75	125	50
100	150	80
150	200	80
200	200	100
300	250	125
400	300	125
500	350	150
700	400	200
800	450	200
1000	500	200
1100	500	250
1400	550	250
1500	600	250

### ② Size of Reservoir; flash steam is not involved

Amount of Condensate (kg/h)	Reservoir Diameter (mm) and Length (m)						
	40	50	80	100	150	200	250
300 or less	1.2m	0.7					
400	1.5	1.0					
500	2.0	1.2	0.5				
600		1.5	0.6				
800		2.0	0.8	0.5			
1000			1.0	0.7			
1500			1.5	1.0			
2000			2.0	1.3	0.6		
3000				2.0	0.9	0.5	
4000					1.2	0.7	
5000					1.4	0.8	0.5
6000					1.7	1.0	0.6
7000					2.0	1.2	0.7
8000						1.3	0.8
9000						1.5	0.9
10000						1.7	1.0

Reservoir length can be reduced by 50% when the motive medium pressure (Pm) divided by back pressure (P2) equals 2 or greater (when  $P_m \div P_2 \geq 2$ ).

③ If flash steam is condensed before it enters the receiver/reservoir, compare tables ① and ② and choose the larger of the two sizes.

## Steam or Air Consumption (Motive Medium)

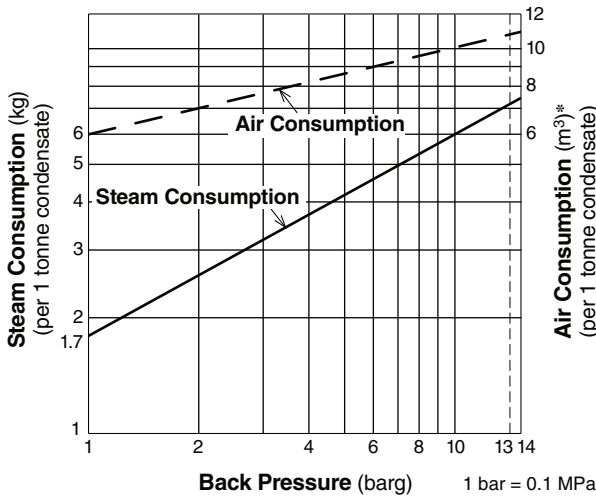

\* Equivalent consumption of air at 20 °C under atmospheric pressure

## Cycle Counter (Option)

Two types of counter can be installed on the GP14L to monitor the number of pumping cycles and help to determine the timing of maintenance, or estimate the volume of pumped condensate.

- **C1CM – (Counter Unit Type):**  
Self-contained standalone unit. Includes an LCD counter display and an operation indicator LED.
- **C1SM – (Terminal Box Type):**  
Designed for use with remote monitoring equipment and systems.

Intrinsically safe models are also available.  
See the Cycle Counter SDS for further details.

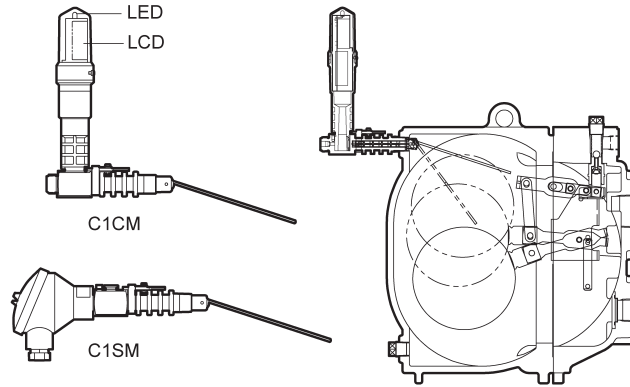

Manufacturer

**TLV** CO., LTD.  
Kakogawa, Japan

is approved by LRQA Ltd. to ISO 9001/14001

ISO 9001/ISO 14001

