

INSTRUCTION MANUAL

Keep this manual in a safe place for future reference

TLV® FREE FLOAT STEAM TRAPS FS SERIES

QuickTrap® FS3/FS5/FS5H



Trap Unit
S3/S5/S5H

(Option
BD2)

Manufacturer

TLV® CO., LTD.

881 Nagasuna, Noguchi, Kakogawa, Hyogo 675-8511, Japan

Tel: [81]-(0)79-427-1800 Fax: [81]-(0)79-422-2277

Copyright (C) 2023 by TLV CO., LTD. All rights reserved.

EAC



Introduction

Before you begin, please read this manual to ensure correct usage of the product, and keep it in a safe place for future reference.

The FS3/FS5/FS5H steam traps (trap units S3/S5/S5H and connector unit F46 or former connector unit F32*), designed for installation in any inclination, are suitable for small and medium capacity applications between 0.01 and 4.6 MPaG (1 and 650 psig); such as saturated and superheated steam mains, branches, tracer lines and small-to-medium size process equipment. The traps discharge condensate continuously and automatically at a temperature slightly lower than saturation temperature.

* Configuration of F32 differs slightly from that of F46

1 MPa = 10.197 kg/cm², 1 bar = 0.1 MPa



For products with special specifications or with options not included in this manual, contact TLV for instructions.

The contents of this manual are subject to change without notice.

1. Safety Considerations

- Read this section carefully before use and be sure to follow the instructions.
- Installation, inspection, maintenance, repairs, disassembly, adjustment and valve opening/closing should be carried out only by trained maintenance personnel.
- The precautions listed in this manual are designed to ensure safety and prevent equipment damage and personal injury. For situations that may occur as a result of erroneous handling, three different types of cautionary items are used to indicate the degree of urgency and the scale of potential damage and danger: DANGER, WARNING and CAUTION.
- The three types of cautionary items above are very important for safety; be sure to observe all of them, as they relate to installation, use, maintenance, and repair. Furthermore, TLV accepts no responsibility for any accidents or damage occurring as a result of failure to observe these precautions.

 DANGER	 WARNING	 CAUTION
Indicates an urgent situation which poses a threat of death or serious injury.	Indicates that there is a potential threat of death or serious injury.	Indicates that there is a possibility of injury or equipment/product damage.

 WARNING	NEVER apply direct heat to the float. The float may explode due to increased internal pressure, causing accidents leading to serious injury or damage to property and equipment.
 CAUTION	Install properly and DO NOT use this product outside the recommended operating pressure, temperature and other specification ranges. Improper use may result in such hazards as damage to the product or malfunctions, which may lead to serious accidents. Local regulations may restrict the use of this product to below the conditions quoted.
	DO NOT use this product in excess of the maximum operating pressure differential. Such use could make discharge impossible (blocked).
	Do not subject the trap to condensate loads that exceed its discharge capacity. Failure to observe this precaution may lead to condensate accumulation upstream of the trap, resulting in reduced equipment performance or damage to the equipment.
	Take measures to prevent people from coming into direct contact with product outlets. Failure to do so may result in burns or other injury from the discharge of fluids.

 CAUTION	<p>When disassembling or removing the product, wait until the internal pressure equals atmospheric pressure and the surface of the product has cooled to room temperature. Disassembling or removing the product when it is hot or under pressure may lead to discharge of fluids, causing burns, other injuries or damage.</p>
	<p>Be sure to use only the recommended components when repairing the product, and NEVER attempt to modify the product in any way. Failure to observe these precautions may result in damage to the product or burns or other injury due to malfunction or the discharge of fluids.</p>
	<p>The pressure and temperature values displayed on the nameplate of the connector body are the values for the connector body itself and not for the entire trap. Improper use may result in such hazards as damage to the product or malfunctions that may lead to serious accidents.</p>
	<p>Use only under conditions in which no freeze-up will occur. Freezing may damage the product, leading to fluid discharge, which may cause burns or other injury.</p>
	<p>Use under conditions in which no water hammer will occur. The impact of water hammer may damage the product, leading to fluid discharge, which may cause burns or other injury.</p>

2. Specifications

Refer to the product nameplates on the trap unit AND on the connector body for detailed specifications. The specifications displayed on each nameplate apply only to the unit on which it is mounted.

When the trap unit is installed on a connector unit and the PMA/TMA and/or PMO/TMO values displayed on the two nameplates differ, the specifications for the assembled product are restricted to the lower values.

Connector Unit (mounted only on F46)

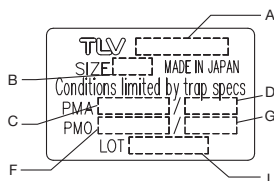

- | | |
|-----------------------------|--------------------------|
| A: Model | F: Max. Operating Press. |
| B: Nominal Diameter* | G: Max. Operating Temp. |
| C: Max. Allowable Press.** | H: Valve No.*** |
| D: Max. Allowable Temp.** | I: Production Lot No. |
| E: Max. Differential Press. | |

Trap Unit

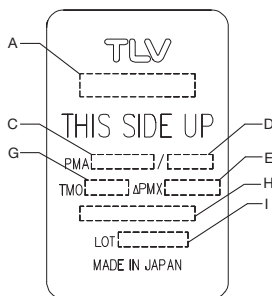

* The nominal diameter is not printed on the trap unit nameplate when the trap unit is shipped by itself.

** Maximum allowable pressure (PMA) and maximum allowable temperature (TMA) are PRESSURE SHELL DESIGN CONDITIONS, **NOT** OPERATING CONDITIONS.

*** "Valve No." is displayed for products with options. This item is omitted from the nameplate when there are no options.



To avoid malfunctions, product damage, accidents or serious injury, install properly and **DO NOT** use this product outside the specification range. Local regulations may restrict the use of this product to below the conditions quoted.

3. Configuration

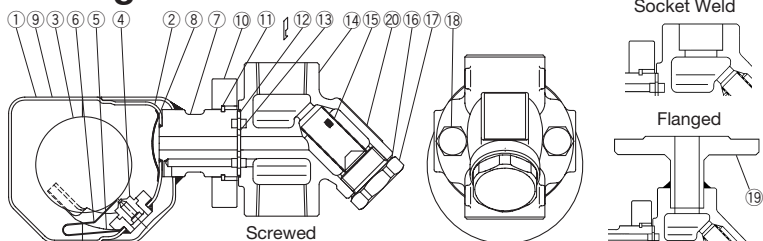

No.	Description	M*	T*	No.	Description	M*	T*	No.	Description	M*	T*
1	Trap body	-	✓	9	Nameplate (Trap Unit)	-	✓	14	Connector Body**	-	-
2	Inner Cover	-	✓	10	Connector Flange	-	✓	15	Screen**	-	-
3	Float	-	✓	11	Snap Ring	-	✓	16	Screen Holder Gasket**	✓	-
4	Orifice	-	✓	12	Outer Connector Gasket	✓	✓	17	Screen Holder**	-	-
5	Float Guide	-	✓	13	Inner Connector Gasket	✓	✓	18	Connector Bolt	-	✓
6	Air Vent Strip	-	✓					19	Flange	-	-
7	Connector Joint	-	✓					20	Nameplate (Connector Unit)	-	-
8	Trap Screen	-	✓								

* Replacement parts are available only in the following kits: M = Maintenance Kit; T = Trap Unit

** Replacement parts for F32 differ from those for F46. When ordering replacement parts, please include the trap unit name, size, connection type and the connector unit name.

4. Exploded View

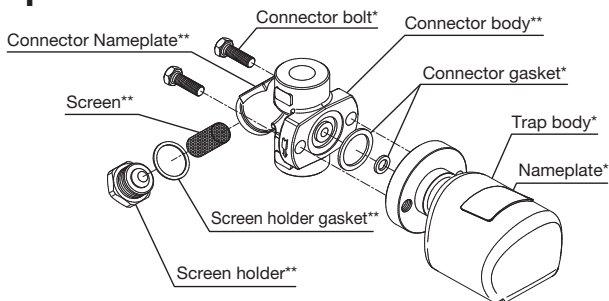

Do not remove snap ring used to fix the connector flange.

* Trap unit S3/S5/S5H

** Connector body unit F46 or F32

Tightening Torque

No.	Description		Tightening Torque N · m (lbf · ft)	Distance across flats	
				mm	(in)
18	Connector Bolt		39 (28)	14	(⁹ / ₁₆)
17	Screen Holder	F46	All connections and sizes	100 (73)	30 (1 ³ / ₁₆)
		F32	F: 15 - 25 mm (1/2", 3/4", 1")*	60 (44)	22 (7/8)
			S & W: 15, 20 mm (1/2", 3/4")*		
			S & W: 25 mm (1")*	150 (110)	38 (1 ¹ / ₂)

Be sure to coat threads on the screen holder and connector bolts with anti-seize. 1 N · m ≈ 10 kg · cm

* F = flanged, S = screwed, W = socket weld.

5. Proper Installation



CAUTION



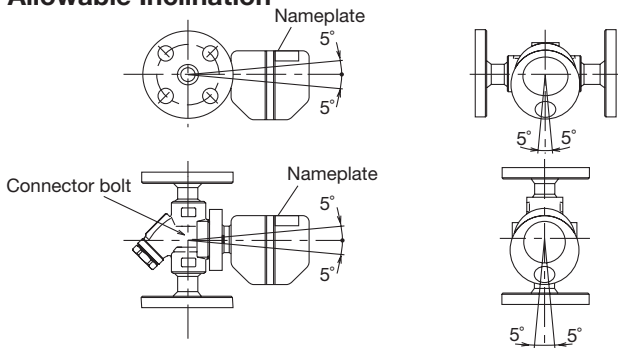

- Installation, inspection, maintenance, repairs, disassembly, adjustment and valve opening/closing should be carried out only by trained maintenance personnel.
 - Take measures to prevent people from coming into direct contact with product outlets.
 - Install for use under conditions in which no freeze-up will occur.
 - Install for use under conditions in which no water hammer will occur.
1. Before installation, be sure to remove all protective seals.
 2. Before installing the steam trap, blow out the inlet piping to remove all dirt and oil.
 3. In some instances, the trap unit and the connector body are sent as separate units. When attaching them together, make sure the connector gaskets are still in place after having removed their protective seal (see page 7 for details).
 4. There are no restrictions on the installation direction beyond the following conditions:
 - a) The arrow on the connector body must point in the direction of condensate flow.
 - b) The connector body must be adjusted so that the connector flange face (for connecting to the trap unit) is in the vertical plane.
 - c) The nameplate on the trap unit must face upward.
 - d) The trap unit must be inclined no more than 5° horizontally and front-to-back.
 5. Install a bypass valve to discharge condensate, and inlet and outlet valves to isolate the trap in the event of trap failure or when performing maintenance.
 6. Install the trap in the lowest part of the pipeline or equipment so the condensate flows naturally into the trap by gravity. The inlet pipe should be as short and have as few bends as possible.
 7. Install a check valve at the trap outlet whenever the condensate discharge pipe leads to a tank or recovery line, or whenever the condensate collection pipeline is connected to more than one trap.
 8. When completing the piping, support the pipes within 0.8 meters (2.5 ft.) on either side of the trap.
 9. In order to avoid excessive back pressure, make sure the discharge pipes are large enough.
 10. The use of unions is recommended to facilitate connection and disconnection of screwed models.

5.1 Allowable Inclination



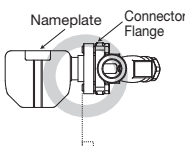

5.2 Installation Examples

Horizontal Piping

Correct	Incorrect			
	Nameplate is not facing upwards.		Universal connector flange is not in the vertical plane.	
 <p>Ground</p>	 <p>Ground</p>	 <p>Ground</p>	 <p>Ground</p>	 <p>Ground</p>

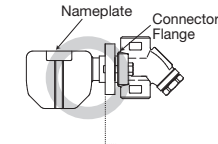
Vertical Piping

Correct	Incorrect	
	Nameplate is not facing upwards.	
 <p>Ground</p>	 <p>Ground</p>	 <p>Ground</p>

5.3 FS5/FS5H, Screwed Model



When using the product on a horizontal pipe, fasten it so that the trap cannot rotate.

To ensure the correct operation of the FS5/FS5H free float steam trap, it is essential that the float mechanism is operating in the horizontal plane. When the screwed model is used in a horizontal pipe, there is a danger that the weight of the steam trap will cause the body to rotate on the pipe, so that the trap mechanism will no longer be in a horizontal plane. In order to prevent this from happening, it is important that the trap body be supported as shown.

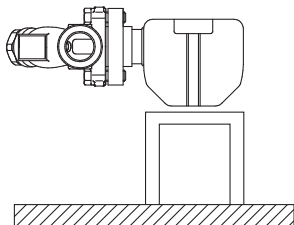

6. Piping Arrangement

Check to make sure that the pipes connected to the trap have been installed properly.

1. Is the pipe diameter suitable?
2. Has the trap unit been installed within the allowable inclination and with the arrow on the body pointing in the direction of flow?
3. Has sufficient space been secured for maintenance?
4. Have maintenance valves been installed at the inlet and outlet? If the outlet is subject to back pressure, has a check valve been installed?
5. Is the inlet pipe as short as possible, with as few bends as possible, and installed so that the condensate will flow naturally down into the trap?
6. Has the piping work been done correctly, as shown in the table below?

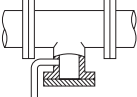
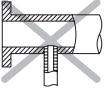
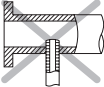
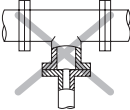
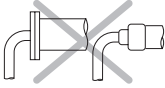
Requirement	Correct	Incorrect
Install a catchpot with the proper diameter.		 <p>Diameter is too small.</p>
Make sure the flow of condensate is not obstructed.		 <p>Diameter is too small and inlet protrudes into pipe.</p>
To prevent rust and scale from flowing into the trap, connect the inlet pipe 25 - 50 mm (1 - 2 in) above the base of the T-pipe.		 <p>Rust and scale flow into the trap with the condensate.</p>
When installing on the blind end, make sure nothing obstructs the flow of condensate.		 <p>Condensate collects in the pipe.</p>

7. Inspection and Maintenance



- Installation, inspection, maintenance, repairs, disassembly, adjustment and valve opening/closing should be carried out only by trained maintenance personnel.
- Before removing the trap body from the connector body, close the inlet and outlet isolation valves and wait until the entire unit has cooled completely. Failure to do so may result in burns.
- Be sure to use the proper components and NEVER attempt to modify the product.

Operational inspections should be performed at least twice per year, or as called for by trap operating conditions. Steam trap failure may result in temperature drop in the equipment, poor product quality or losses due to steam leakage.

While the trap body itself is maintenance-free, there may be other causes of malfunction, as described in the “Troubleshooting” and “Piping Arrangement” chapters. If the corrective measures described therein do not solve the problem, it is possible that the trap has reached the end of its service life and requires replacement.

7.1 Separating/Attaching Trap and Connector Bodies

- Loosen and remove the connector bolts, remove the entire trap unit from the connector body and take it to a repair area where it can be supported in a vise during disassembly.
- When reinstalling the original trap:
 - Using a small screwdriver, remove the old gaskets from their housings in the trap body, then clean the housings.
 - New connector gaskets must be installed.
 - To facilitate assembly and prevent loosening of the gaskets, apply a small amount of suitable adhesive at 120° intervals around the outer edge of the gaskets.
 - Holding the trap body so that the gasket housings are horizontal, place the gaskets into the housings.
- When installing a replacement trap:
 - Be sure to remove all protective seals, making sure the connector gaskets are still in place after having removed their seal.
 - Before installation, scrape the mounting surface of the connector body clean using a soft tool.
- Align the bottom edge of the trap body with that of the connector body (see Fig. A below), making sure the gasket housings on the trap body align with the corresponding recesses in the connector body. Maintaining the proper alignment, close the tops together until the two faces are flush, making sure that connector gaskets remain in position.
- Insert the connector bolts and finger-tighten, keeping trap and connector bodies flush. Tighten the connector bolts to the proper torque (see p.3).

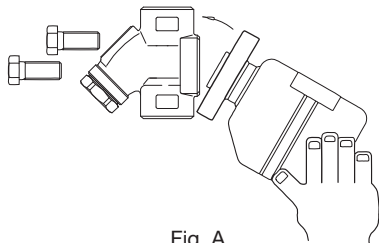

Fig. A

Trap units S3/S5/S5H are designed for use with TLV F46 and F32 connector units, trap stations (V1/V2/V1P/V2P Series) and QuickStation QS10. The connector unit name is indicated on the connector body.

8. Operational Check

A visual inspection can be carried out to aid in determining the necessity for immediate maintenance or repair, if the trap is open to atmosphere. If the trap does not discharge to atmosphere, use diagnostic equipment such as TLV TrapMan or Pocket TrapMan (within their pressure and temperature measuring range).

Normal:	Condensate is discharged continuously with flash steam and the sound of flow can be heard. If there is very little condensate, there is almost no sound of flow.
Blocked:	No condensate is discharged. The trap is quiet and makes no noise, and the surface temperature of the trap is low.
Blowing:	Live steam continually flows from the outlet and there is a continuous metallic sound.
Steam Leakage:	Live steam is discharged through the trap outlet together with the condensate and there is a high-pitched sound.

(When conducting a visual inspection, flash steam is sometimes mistaken for steam leakage. For this reason, the use of a steam trap diagnostic instrument such as TLV TrapMan is highly recommended.)

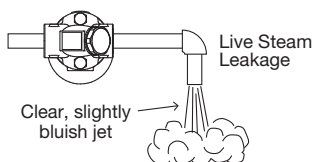
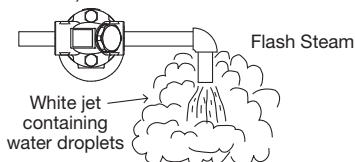

9. Instructions for Plug / Holder Disassembly and Reassembly

The seal on the threaded plugs/holders found on TLV products is formed by a flat metal gasket. There are various installation orientations for the gaskets, such as horizontal, diagonal and downward, and the gasket may be pinched in the thread recesses during assembly.

Instructions for Disassembly and Reassembly

- Remove the plug/holder using a tool of the specified size (distance across flats).
- The gasket should not be reused. Be sure to replace it with a new gasket.
- Clean the gasket surfaces of the plug/holder and the product body using a rag and/or cleaning agents, then check to make sure the surfaces are not scratched or deformed.
- Coat both the gasket surface of the plug/holder and the threads of the plug/holder with anti-seize, then press the gasket onto the center of the gasket surface of the plug/holder, making sure the anti-seize affixes the gasket tightly to the plug/holder. Check to make sure the gasket is not caught in the recesses of the threads.
- Hold the plug/holder upside down to make sure that the anti-seize makes the gasket stick to the plug/holder even when the plug/holder is held upside down.
- Screw the plug/holder by hand into the product body while making sure that the gasket remains tightly affixed to the center of the gasket surface of the plug/holder. Make sure the entire gasket is making contact with the gasket surface of the product body. It is important at this point to make sure the gasket is not pinched in the thread recesses of the plug/holder.
- Tighten the plug/holder to the proper torque.
- Next, begin the supply of steam and check to make sure there is no leakage from the part just tightened. If there is leakage, immediately close the inlet valve and, if there is a bypass valve, take the necessary steps to release any residual pressure. After the surface of the product cools to room temperature, repeat the procedure beginning from step ①.

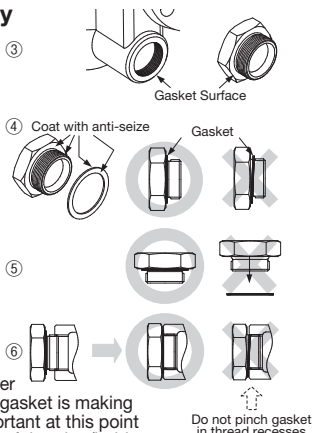

10. Troubleshooting

If the expected performance is unachievable after installation of the steam trap, read chapters 5 and 6 again and check the following points for appropriate corrective measures.

Problem	Cause	Corrective Measures
No condensate is discharged (blocked), or discharge is poor	Pressure exceeds maximum operating pressure	Replace trap with appropriately rated model or, if possible, reduce steam pressure
	Pipelines upstream or downstream of the trap are clogged	Clean the pipelines
	In the connector body, the screen or the inlet and outlet channels are clogged	Clean screen or channels
	In the trap body, the inlet and outlet channels are clogged	Replace the trap body with a new one
	The trap capacity is too small	Replace with larger trap
Steam leakage or blow-off	Steam locking has occurred	Perform a bypass blowdown, or close the trap inlet valve and allow the trap to cool
	Trap is installed above the maximum allowable inclination	Correct the installation
	Severe vibration of trap	Reinforce trap piping supports
Steam leaks from a place other than the outlet	Water hammer has occurred	Examine the piping for problems
	Screen holder gasket or connector gaskets are loose or damaged	Tighten to the proper torque (see page 3) or replace gaskets

NOTE: When replacing parts with new, use the parts list on page 3 for reference, and replace with parts from the Maintenance Kit and/or the Trap Unit.

11. Optional Blowdown Valve BD2

The BD2 blowdown valve, installed in place of the screen holder, uses internal pressure to blow out condensate/steam, dirt and scale to the atmosphere.

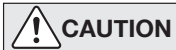

• Installation, inspection, maintenance, repairs, disassembly, adjustment and valve opening/closing should be carried out only by trained maintenance personnel.

- When disassembling or removing the product, wait until the internal pressure equals atmospheric pressure and the surface of the product has cooled to room temperature.
- Do not tighten the BD2 valve or the BD2 valve seat in excess of the appropriate tightening torque. Over-tightening may cause breakage to threaded portions, which may cause burns, other injuries or damage.

11.1 Reassembly of Blowdown Valve

1. Clean the trap, BD2 threads, and sealing surfaces, and apply a small amount of anti-seize.
2. Replace gasket.
3. Carefully place the gasket over the threaded portion, and position carefully so that it does not become off-center.
4. Fasten to the steam trap with the proper torque.

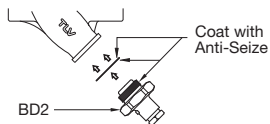

Torque (T) and Distance Across Flats (D)

	①	BD2 Valve		(T): 30 N·m (22 lbf·ft) (D): 17 mm ($2\frac{1}{32}$ ")	
	②	BD2 Valve Seat (Screen Holder)	F46	All connections and sizes	(T): 100 N·m (73 lbf·ft) (D): 30 mm ($1\frac{3}{16}$ ")
			F32	Flanged 15 - 25 mm ($\frac{1}{2}$ "-1") Screwed & Socket Weld	(T): 60 N·m (43 lbf·ft) (D): 22 mm ($\frac{7}{8}$ ")
				Screwed & Socket Weld 25 mm (1")	(T): 150 N·m (110 lbf·ft) (D): 38 mm ($1\frac{1}{2}$ ")

11.2 Operation Instructions for BD2

Note: Do not leave the vicinity while the blowdown valve is in the open position.



• Always wear eye protection and heat-resistant gloves when operating the blowdown valve. Failure to do so may result in burns or other injury.

- When operating the blowdown valve, stand to the side well clear of the outlet to avoid contact with internal fluids that will be discharged. Operate the valve slowly and surely, taking care to avoid the area from which internal fluids are discharged and any fluids deflected off piping or the ground etc. Failure to do so may result in burns or other injury.
- Do not excessively loosen the BD2 valve when opening the blowdown valve. The valve stopper pin installed to prevent the BD2 valve from being removed may break and internal pressure may result in the BD2 valve being blown off, leading to injuries, damage and fluid discharge, causing burns.

1. With two wrenches, firmly hold the BD2 valve seat (screen holder) ② (22 mm, $\frac{7}{8}$ ") in place while slowly opening the BD2 valve ① (17 mm, $2\frac{1}{32}$ "). Be careful to avoid contact with fluid that will be discharged through the hole in the center of the blowdown valve as the valve opens.
2. Close the BD2 valve ① and tighten to a torque of 30 N·m (22 lbf·ft), and confirm that there is no leakage. If leakage continues, dirt or scale may prevent the valve from sealing. Open and blow out again, then try to close once more.

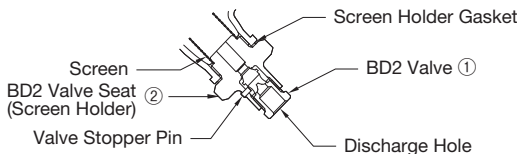

12. TLV EXPRESS LIMITED WARRANTY

Subject to the limitations set forth below, TLV Corporation, a North Carolina corporation (“TLV”) warrants that products which are sold by it, TLV CO., LTD., a Japanese corporation (“TLVJ”) or TLV International, Inc., a Japanese corporation (“TII”), (hereinafter the “Products”) are designed and manufactured by TLVJ, conform to the specifications published by TLV for the corresponding part numbers (the “Specifications”) and are free from defective workmanship and materials. With regard to products or components manufactured by unrelated third parties (the “Components”), TLV provides no warranty other than the warranty from the third party manufacturer(s), if any.

Exceptions to Warranty

This warranty does not cover defects or failures caused by:

1. improper shipping, installation, use, handling, etc., by other than TLV or service representatives authorized by TLV; or
2. dirt, scale or rust, etc.; or
3. improper disassembly and reassembly, or inadequate inspection and maintenance by other than TLV or service representatives authorized by TLV; or
4. disasters or forces of nature or Acts of God; or
5. abuse, abnormal use, accidents or any other cause beyond the control of TLV; or
6. improper storage, maintenance or repair; or
7. operation of the Products not in accordance with instructions issued with the Products or with accepted industry practices; or
8. use for a purpose or in a manner for which the Products were not intended; or
9. use of the Products in a manner inconsistent with the Specifications; or
10. use of the Products with Hazardous Fluids (fluids other than steam, air, water, nitrogen, carbon dioxide and inert gases (helium, neon, argon, krypton, xenon and radon)); or
11. failure to follow the instructions contained in the TLV Instruction Manual for the Product.

Duration of Warranty

This warranty is effective for a period of the earlier of: (i) three (3) years after delivery of Products to the first end user in the case of sealed SST-Series Products for use in steam pressure service up to 650 psig; (ii) two (2) years after delivery of Products to the first end user in the case of PowerTrap® units; or (iii) one (1) year after delivery of Products to the first end user in the case of all other Products. Notwithstanding the foregoing, asserting a claim under this warranty must be brought by the earlier of one of the foregoing periods, as applicable, or within five (5) years after the date of delivery to the initial buyer if not sold initially to the first end user.

ANY IMPLIED WARRANTIES NOT NEGATED HEREBY WHICH MAY ARISE BY OPERATION OF LAW, INCLUDING THE IMPLIED WARRANTIES OF MERCHANTABILITY AND FITNESS FOR A PARTICULAR PURPOSE AND ANY EXPRESS WARRANTIES NOT NEGATED HEREBY, ARE GIVEN SOLELY TO THE INITIAL BUYER AND ARE LIMITED IN DURATION TO ONE (1) YEAR FROM THE DATE OF SHIPMENT BY TLV.

Exclusive Remedy

THE EXCLUSIVE REMEDY UNDER THIS WARRANTY, UNDER ANY EXPRESS WARRANTY OR UNDER ANY IMPLIED WARRANTIES NOT NEGATED HEREBY (INCLUDING THE IMPLIED WARRANTIES OF MERCHANTABILITY AND FITNESS FOR A PARTICULAR PURPOSE), IS **REPLACEMENT**; PROVIDED: (a) THE CLAIMED DEFECT IS REPORTED TO TLV IN WRITING WITHIN THE APPLICABLE WARRANTY PERIOD, INCLUDING A DETAILED WRITTEN DESCRIPTION OF THE CLAIMED DEFECT AND HOW AND WHEN THE CLAIMED DEFECTIVE PRODUCT WAS USED; AND (b) THE CLAIMED DEFECTIVE PRODUCT AND A COPY OF THE PURCHASE INVOICE IS RETURNED TO TLV, FREIGHT AND TRANSPORTATION COSTS PREPAID, UNDER A RETURN MATERIAL AUTHORIZATION AND TRACKING NUMBER ISSUED BY TLV. ALL LABOR COSTS, SHIPPING COSTS, AND TRANSPORTATION COSTS ASSOCIATED WITH THE RETURN OR REPLACEMENT OF THE CLAIMED DEFECTIVE PRODUCT ARE SOLELY THE RESPONSIBILITY OF BUYER OR THE FIRST END USER. TLV RESERVES THE RIGHT TO INSPECT ON THE FIRST END USER'S SITE ANY PRODUCTS CLAIMED TO BE DEFECTIVE BEFORE ISSUING A RETURN MATERIAL AUTHORIZATION. SHOULD SUCH INSPECTION REVEAL, IN TLV'S REASONABLE DISCRETION, THAT THE

CLAIMED DEFECT IS NOT COVERED BY THIS WARRANTY, THE PARTY ASSERTING THIS WARRANTY SHALL PAY TLV FOR THE TIME AND EXPENSES RELATED TO SUCH ON-SITE INSPECTION.

Exclusion of Consequential and Incidental Damages

IT IS SPECIFICALLY ACKNOWLEDGED THAT THIS WARRANTY, ANY OTHER EXPRESS WARRANTY NOT NEGATED HEREBY, AND ANY IMPLIED WARRANTY NOT NEGATED HEREBY, INCLUDING THE IMPLIED WARRANTIES OF MERCHANTABILITY AND FITNESS FOR A PARTICULAR PURPOSE, DO NOT COVER, AND NEITHER TLV, TII NOR TLVJ WILL IN ANY EVENT BE LIABLE FOR, INCIDENTAL OR CONSEQUENTIAL DAMAGES, INCLUDING, BUT NOT LIMITED TO LOST PROFITS, THE COST OF DISASSEMBLY AND SHIPMENT OF THE DEFECTIVE PRODUCT, INJURY TO OTHER PROPERTY, DAMAGE TO BUYER'S OR THE FIRST END USER'S PRODUCT, DAMAGE TO BUYER'S OR THE FIRST END USER'S PROCESSES, LOSS OF USE, OR OTHER COMMERCIAL LOSSES. WHERE, DUE TO OPERATION OF LAW, CONSEQUENTIAL AND INCIDENTAL DAMAGES UNDER THIS WARRANTY, UNDER ANY OTHER EXPRESS WARRANTY NOT NEGATED HEREBY OR UNDER ANY IMPLIED WARRANTY NOT NEGATED HEREBY (INCLUDING THE IMPLIED WARRANTIES OF MERCHANTABILITY AND FITNESS FOR A PARTICULAR PURPOSE) CANNOT BE EXCLUDED, SUCH DAMAGES ARE EXPRESSLY LIMITED IN AMOUNT TO THE PURCHASE PRICE OF THE DEFECTIVE PRODUCT. THIS EXCLUSION OF CONSEQUENTIAL AND INCIDENTAL DAMAGES, AND THE PROVISION OF THIS WARRANTY LIMITING REMEDIES HEREUNDER TO REPLACEMENT, ARE INDEPENDENT PROVISIONS, AND ANY DETERMINATION THAT THE LIMITATION OF REMEDIES FAILS OF ITS ESSENTIAL PURPOSE OR ANY OTHER DETERMINATION THAT EITHER OF THE ABOVE REMEDIES IS UNENFORCEABLE, SHALL NOT BE CONSTRUED TO MAKE THE OTHER PROVISIONS UNENFORCEABLE.

Exclusion of Other Warranties

THIS WARRANTY IS IN LIEU OF ALL OTHER WARRANTIES, EXPRESS OR IMPLIED, AND ALL OTHER WARRANTIES, INCLUDING BUT NOT LIMITED TO THE IMPLIED WARRANTIES OF MERCHANTABILITY AND FITNESS FOR A PARTICULAR PURPOSE, ARE EXPRESSLY DISCLAIMED.

Severability

Any provision of this warranty which is invalid, prohibited or unenforceable in any jurisdiction shall, as to such jurisdiction, be ineffective to the extent of such invalidity, prohibition or unenforceability without invalidating the remaining provisions hereof, and any such invalidity, prohibition or unenforceability in any such jurisdiction shall not invalidate or render unenforceable such provision in any other jurisdiction.

TLV CORPORATION

13901 South Lakes Drive, Charlotte, NC 28273-6790, U.S.A.

Tel: [1]-704-597-9070

Fax: [1]-704-583-1610

Printed on recycled paper.

PAC-65337-a

Rev. 8/2023 (M)