

# INSTRUCTION MANUAL

Keep this manual in a safe place for future reference

## TLV® THERMOSTATIC AIR VENTS FOR STEAM LA SERIES

### LA13 / LA13L / LA21



LA13



LA21



LA13L

Manufacturer

**TLV® CO., LTD.**

881 Nagasuna, Noguchi, Kakogawa, Hyogo 675-8511, Japan

Tel: [81]-(0)79-427-1800 Fax: [81]-(0)79-422-2277

Copyright (C) 2023 by TLV CO., LTD. All rights reserved.

**EAC**



# Introduction

Before beginning installation or maintenance, please read this manual to ensure correct usage of the product. Keep the manual in a safe place for future reference.

The LA Series air vents LA13, LA21 and LA13L can be used for steam pipelines and medium capacity steam-using equipment up to 1.3, or 2.1 MPaG (185, or 300 psig). These models discharge air and condensate slightly below steam saturation temperature.

1 MPa = 10.197 kg/cm<sup>2</sup>, 1 bar = 0.1 MPa

For products with special specifications or with options not included in this manual, contact TLV for instructions.

The contents of this manual are subject to change without notice.

## 1. Safety Considerations

- Read this section carefully before use and be sure to follow the instructions.
- Installation, inspection, maintenance, repairs, disassembly, adjustment and valve opening/closing should be carried out only by trained maintenance personnel.
- The precautions listed in this manual are designed to ensure safety and prevent equipment damage and personal injury. For situations that may occur as a result of erroneous handling, three different types of cautionary items are used to indicate the degree of urgency and the scale of potential damage and danger: DANGER, WARNING and CAUTION.
- The three types of cautionary items above are very important for safety; be sure to observe all of them, as they relate to installation, use, maintenance, and repair. Furthermore, TLV accepts no responsibility for any accidents or damage occurring as a result of failure to observe these precautions.

 Indicates a DANGER, WARNING or CAUTION item.

 **DANGER** Indicates an urgent situation that poses a threat of death or serious injury.

 **WARNING** Indicates that there is a potential threat of death or serious injury.

 **CAUTION** Indicates that there is a possibility of injury, or equipment/product damage.

	<p><b>Install properly and DO NOT use this product outside the recommended operating pressure, temperature and other specification ranges.</b> Improper use may result in such hazards as damage to the product or malfunctions, which may lead to serious accidents. Local regulations may restrict the use of this product to below the conditions quoted.</p>
 <b>CAUTION</b>	<p><b>Take measures to prevent people from coming into direct contact with product outlets.</b> Failure to do so may result in burns or other injury from the discharge of fluids.</p>
	<p><b>When disassembling or removing the product, wait until the internal pressure equals atmospheric pressure and the surface of the product has cooled to room temperature.</b> Disassembling or removing the product when it is hot or under pressure may lead to discharge of fluids, causing burns, other injuries or damage.</p>

Continued on the next page

 <b>CAUTION</b>	<b>Be sure to use only the recommended components when repairing the product, and NEVER attempt to modify the product in any way.</b> Failure to observe these precautions may result in damage to the product or burns or other injury due to malfunction or the discharge of fluids.
	<b>Use only under conditions in which no freeze-up will occur.</b> Freezing may damage the product, leading to fluid discharge, which may cause burns or other injury.
	<b>Use under conditions in which no water hammer will occur.</b> The impact of water hammer may damage the product, leading to fluid discharge, which may cause burns or other injury.

## 2. Specifications

Refer to the product nameplate for detailed specifications.

- A Model
- B Nominal Diameter
- C Maximum Allowable Pressure\*
- D Maximum Allowable Temperature\* TMA
- E Maximum Operating Pressure
- F Maximum Operating Temperature TMO
- G Production Lot No.
- H Tag No.\*\*
- I X-element Type

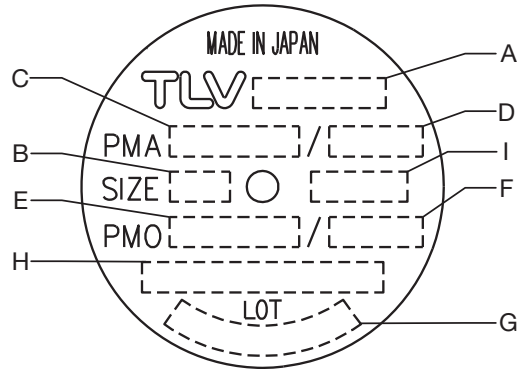
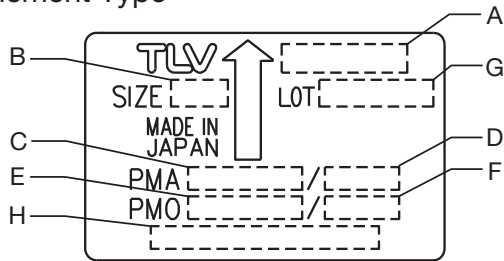

\* Maximum allowable pressure (PMA) and maximum allowable temperature (TMA) are PRESSURE SHELL DESIGN CONDITIONS, **NOT** OPERATING CONDITIONS.

\*\* "Tag No." is displayed for products with options. This item is omitted from the nameplate when there are no options.



To avoid malfunctions, product damage, accidents or serious injury, install properly and DO NOT use this product outside the specification range. Local regulations may restrict the use of this product to below the conditions quoted.

### 2.1 Maximum Operating Temperature

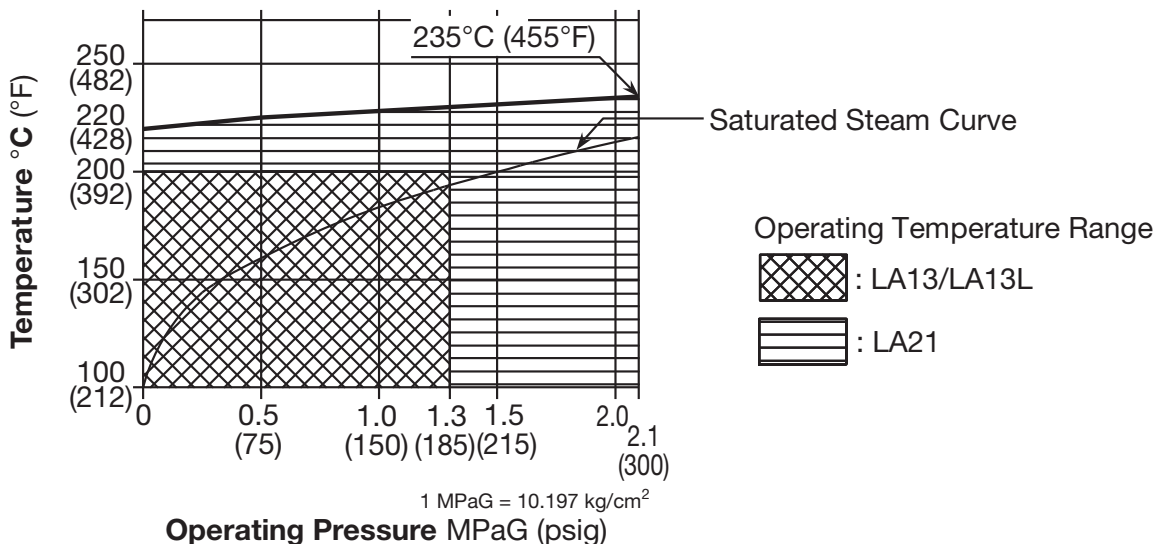

### 3. Configuration

LA13

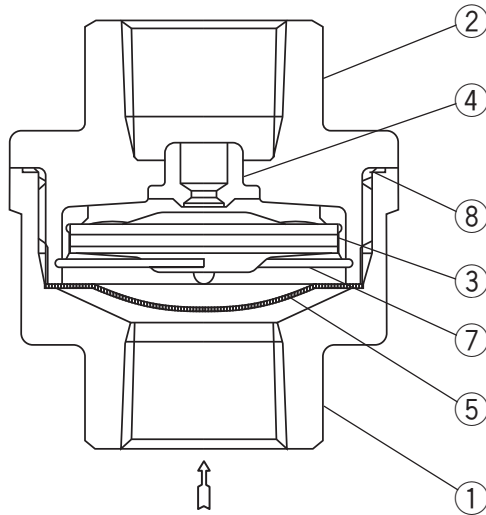

LA21

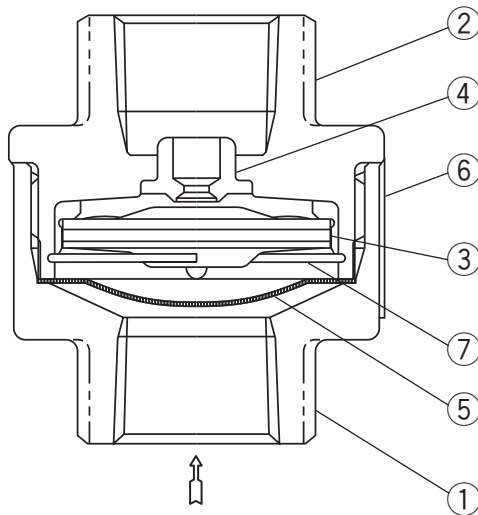

No.	Description
1	Body
2	Cover
3	X-element
4	Valve Seat
5	Screen
6	Nameplate
7	Spring Clip
8*	Cover Gasket
9**	X-element Guide

\* LA13, LA13L \*\* LA13L

LA13L

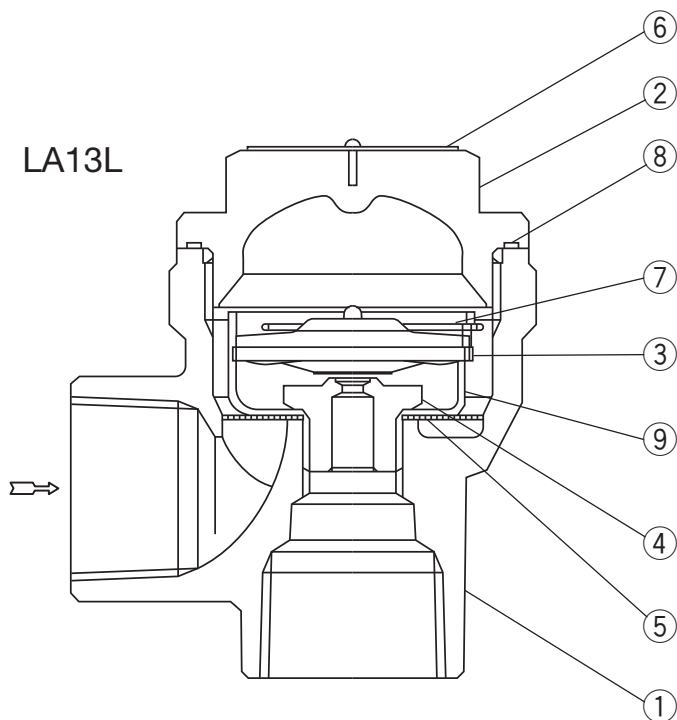

# 4. Exploded View

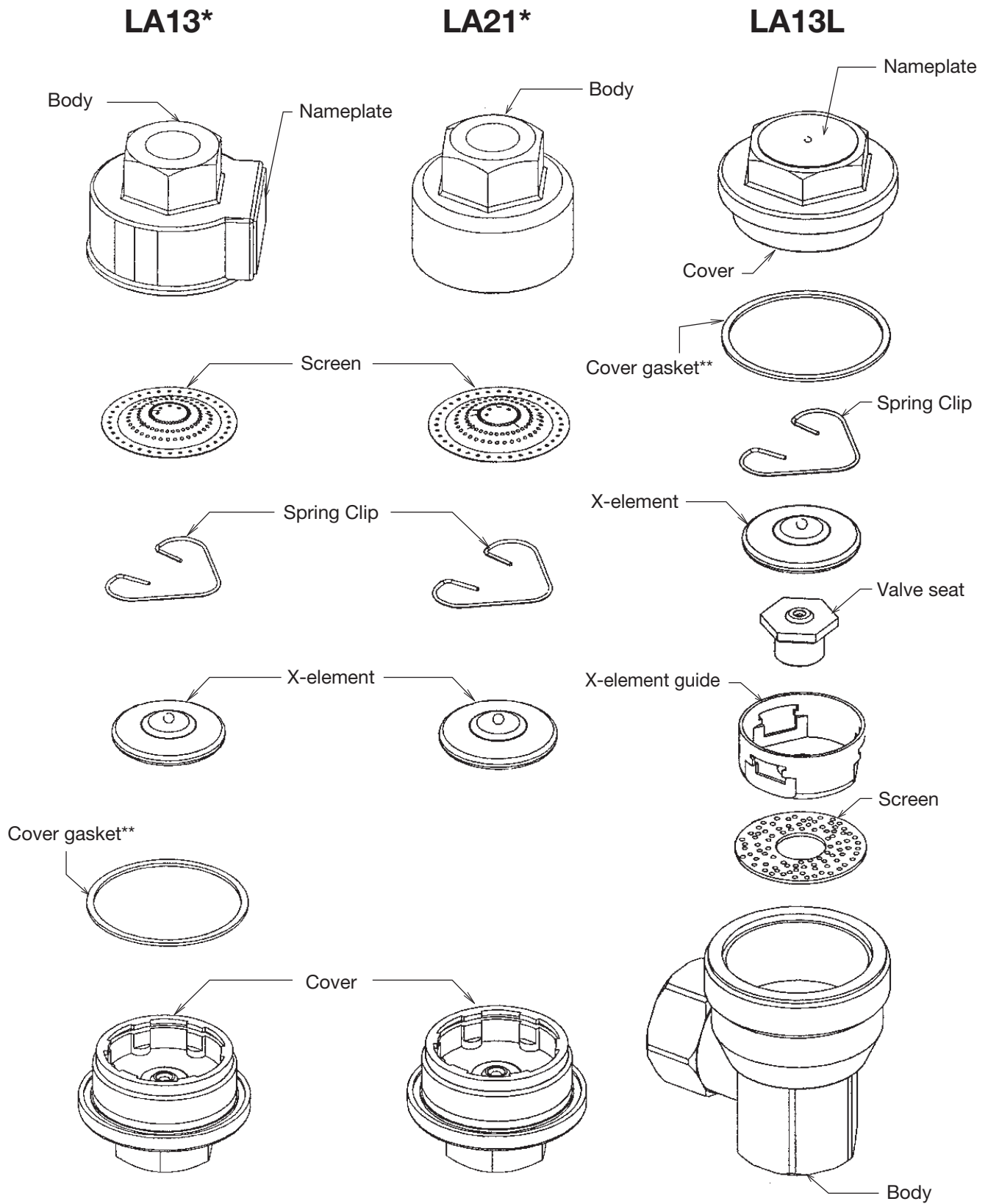

\* Shown upside-down for maintenance.

\*\* LA13, LA13L

## 5. Proper Installation



- Installation, inspection, maintenance, repairs, disassembly, adjustment and valve opening/closing should be carried out only by trained maintenance personnel.
  - Take measures to prevent people from coming into direct contact with product outlets.
  - Do not use excessive force when connecting threaded pipes.
  - Install for use under conditions in which no freeze-up will occur.
  - Install for use under conditions in which no water hammer will occur.
1. Before installation, be sure to remove all protective seals.
  2. Before installing the product, blow out the inlet piping to remove any piping scraps, dirt and oil. Close the inlet valve after blowdown.
  3. Install the air vent at a point where air tends to collect (essentially a place away from the steam inlet of the equipment). To increase the effectiveness of air removal also install an air vent in front of the steam-using equipment.
  4. Install the air vent vertically (LA13, LA21) with the arrow on the nameplate or body (LA13L) pointing in the direction of flow. **DO NOT** install the air vent upside down.
  5. To protect people from hot air or steam from the outlet of the air vent connect a pipe leading to a pit but do not submerge the pipe in water; this may result in air vent failure if the pipe sucks up water containing rust and dirt.
  6. The use of unions is recommended to facilitate connection and disconnection of the air vent.

## 6. Piping Arrangement

Check to make sure that the pipes connected to the air vent have been installed properly.

1. Has the piping work been done as shown on the sketch below?
2. Is the pipe diameter suitable?
3. Has the air vent been installed with the arrow on the nameplate or body (LA13L) pointing in the direction of flow?
4. Has sufficient space been secured for maintenance?

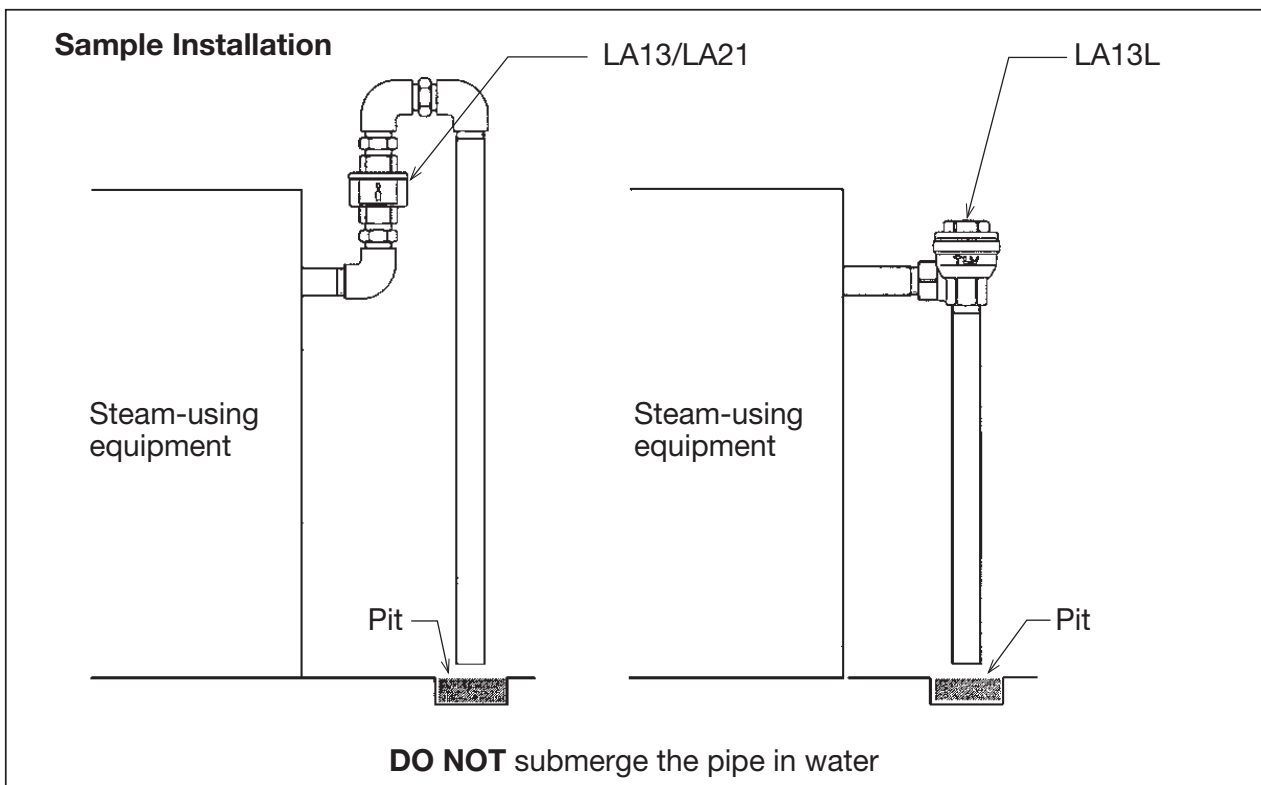

# 7. Operational Check

A visual inspection can be done to help decide about necessary immediate maintenance or repair if the air vent is open to atmosphere.

Normal:	The sound of flow can be heard while air is discharged. When air discharge finishes, the valve closes along with slight discharge of steam.
Blocked (no discharge):	No air is discharged. The air vent is quiet and its surface temperature is low.
Blowing:	Live steam continually blows from the outlet and there is a continuous metallic sound.
Steam Leakage:	Live steam is leaking through the outlet, accompanied by a high-pitched sound.

Use diagnostic equipment such as **TLV** Pocket TrapMan if the air vent does not discharge to atmosphere.

# 8. Inspection and Maintenance

Operational inspections should be performed at least twice per year, or as called for by trap operating conditions. Faulty air vents may result in losses due to steam leakage. Follow the instructions below for disassembly and reassembly when cleaning or repair is necessary.



• Installation, inspection, maintenance, repairs, disassembly, adjustment and valve opening/closing should be carried out only by trained maintenance personnel.

- Before attempting to open the vent, close the inlet isolation valve of the equipment and wait until the air vent has cooled to room temperature. Failure to do so may result in burns or injury.
- LA13L can be maintained without being removed from the pipeline, on the condition that the surrounding pipes are securely supported. If the pipes are not properly supported, they may be damaged when torque is applied in the loosening or tightening of the cover. Such damage could result in steam spraying out and causing serious injury.
- If using a vise when dismantling the air vent, screw a nipple or pipe end into the outlet to prevent deformation of the threaded connection.
- Be sure to use the proper components and NEVER attempt to modify the product.

### Parts Inspection

Part	Procedure
Gasket	Check for warping or damage (LA13, LA13L only).
Screen	Check for clogging or corrosion damage.
X-element	Check for rust, scale, oil film, wear or damage.
Valve seat	Check for rust, scale, oil film, wear or damage.
Body, Cover	Check inside for rust and scale.

Tightening Torque and Distance Across Flats			
Part	Tightening torque		Distance across flats
	N·m	(lbf·ft)	mm (in)
Cover LA13, Size 15 mm (1/2")	80	(59)	27 (1 1/16)
Cover LA13, Size 20, 25 mm (3/4", 1")	80	(59)	41 (1 5/8)
Cover LA21	120	(88)	27 (1 1/16)
Cover LA13L	80	(59)	32 (1 1/4)
Valve Seat LA13L	35	(26)	19 (3/4)

1 N·m ≈ 10 kg·cm

If drawings or other special documentation were supplied for the product, any torque given there takes precedence over values shown here.



<b>Disassembly/Reassembly</b> (to reassemble, follow procedures in reverse)		
Part & No.	During Disassembly	During Reassembly
Body 1 / Cover 2	Use a wrench to remove	Clean seating surfaces between cover and body, coat threads (only LA21) with anti-seize, tighten to the proper torque
Cover Gasket 8 (LA13, LA13L)	Remove gasket only if worn or damaged	Replace with a new gasket only if worn or damaged
Spring Clip 7	Use appropriate pliers to remove	Insert securely into the 3 slots on the X-element guide or cover (figure A)
X-element 3	Use pliers to grip ball at the tip of the X-element	Insert right side up making sure not to catch the guide or cover (figure B)
Valve Seat 4 (LA13L)	Use a wrench to remove	Tighten to the proper torque
X-element Guide 9 (LA13L)	Be careful not to bend	Fix with Valve Seat and make sure X-element can be inserted smoothly
Screen 5	Be careful not to bend	Insert carefully without bending

### Installation of X-element

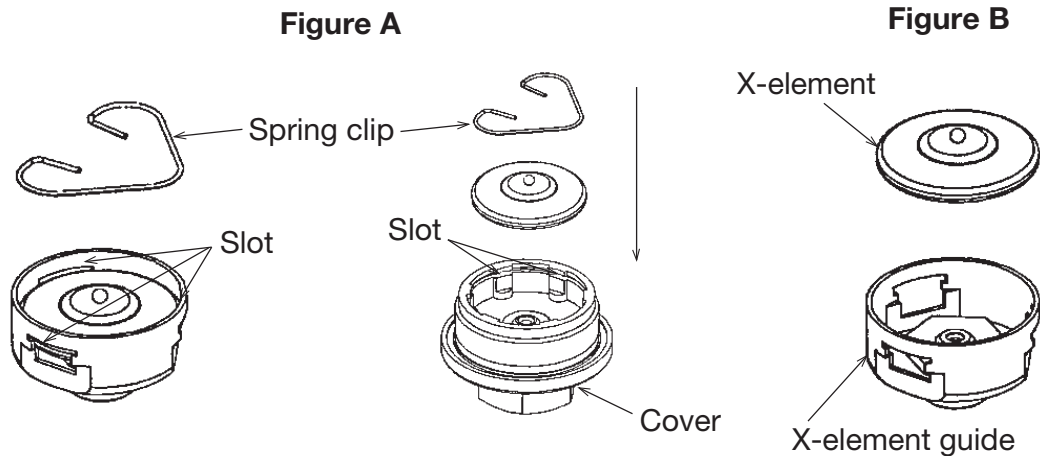

## 9. Troubleshooting

If the expected performance is unachievable after installation of the air vent, read chapter 5 and chapter 6 again and check the following points to take appropriate corrective measures.

<b>Problem</b>	<b>Cause</b>	<b>Remedy</b>
No air is discharged (blocked) or discharge is poor	The X-element is stuck to the valve seat	Clean parts
	The valve seat is blocked	Clean the valve seat, or replace with a new valve seat (LA13L) or cover
	The screen is clogged	Clean parts
	The air vent operating pressure exceeds the maximum specified pressure, or there is insufficient pressure differential between the air vent inlet and outlet	Compare specifications and actual operating conditions
Steam is discharged or leaks from the outlet (blowing) (steam leakage)	There is rust or scale between the X-element valve and valve seat	Clean parts
	The X-element valve and valve seat are damaged	Replace with a new X-element and/or cover (LA13L: also the valve seat)
	The X-element is broken	Replace with a new X-element
	Improper installation	Correct the installation
	Air vent vibration	Lengthen the inlet piping and fasten it securely
Steam is leaking from a place other than the outlet	Gasket deterioration or damage	Replace with a new gasket
	Improper tightening torques were used	Tighten to the proper torque





# 10. TLV EXPRESS LIMITED WARRANTY

Subject to the limitations set forth below, TLV Corporation, a North Carolina corporation (“**TLV**”) warrants that products which are sold by it, TLV CO., LTD., a Japanese corporation (“**TLVJ**”) or TLV International, Inc., a Japanese corporation (“**TII**”), (hereinafter the “**Products**”) are designed and manufactured by TLVJ, conform to the specifications published by TLV for the corresponding part numbers (the “**Specifications**”) and are free from defective workmanship and materials. With regard to products or components manufactured by unrelated third parties (the “**Components**”), TLV provides no warranty other than the warranty from the third party manufacturer(s), if any.

## Exceptions to Warranty

This warranty does not cover defects or failures caused by:

1. improper shipping, installation, use, handling, etc., by other than TLV or service representatives authorized by TLV; or
2. dirt, scale or rust, etc.; or
3. improper disassembly and reassembly, or inadequate inspection and maintenance by other than TLV or service representatives authorized by TLV; or
4. disasters or forces of nature or Acts of God; or
5. abuse, abnormal use, accidents or any other cause beyond the control of TLV; or
6. improper storage, maintenance or repair; or
7. operation of the Products not in accordance with instructions issued with the Products or with accepted industry practices; or
8. use for a purpose or in a manner for which the Products were not intended; or
9. use of the Products in a manner inconsistent with the Specifications; or
10. use of the Products with Hazardous Fluids (fluids other than steam, air, water, nitrogen, carbon dioxide and inert gases (helium, neon, argon, krypton, xenon and radon)); or
11. failure to follow the instructions contained in the TLV Instruction Manual for the Product.

## Duration of Warranty

This warranty is effective for a period of the earlier of: (i) three (3) years after delivery of Products to the first end user in the case of sealed SST-Series Products for use in steam pressure service up to 650 psig; (ii) two (2) years after delivery of Products to the first end user in the case of PowerTrap® units; or (iii) one (1) year after delivery of Products to the first end user in the case of all other Products. Notwithstanding the foregoing, asserting a claim under this warranty must be brought by the earlier of one of the foregoing periods, as applicable, or within five (5) years after the date of delivery to the initial buyer if not sold initially to the first end user.

ANY IMPLIED WARRANTIES NOT NEGATED HEREBY WHICH MAY ARISE BY OPERATION OF LAW, INCLUDING THE IMPLIED WARRANTIES OF MERCHANTABILITY AND FITNESS FOR A PARTICULAR PURPOSE AND ANY EXPRESS WARRANTIES NOT NEGATED HEREBY, ARE GIVEN SOLELY TO THE INITIAL BUYER AND ARE LIMITED IN DURATION TO ONE (1) YEAR FROM THE DATE OF SHIPMENT BY TLV.

## Exclusive Remedy

THE EXCLUSIVE REMEDY UNDER THIS WARRANTY, UNDER ANY EXPRESS WARRANTY OR UNDER ANY IMPLIED WARRANTIES NOT NEGATED HEREBY (INCLUDING THE IMPLIED WARRANTIES OF MERCHANTABILITY AND FITNESS FOR A PARTICULAR PURPOSE), IS **REPLACEMENT**; PROVIDED: (a) THE CLAIMED DEFECT IS REPORTED TO TLV IN WRITING WITHIN THE APPLICABLE WARRANTY PERIOD, INCLUDING A DETAILED WRITTEN DESCRIPTION OF THE CLAIMED DEFECT AND HOW AND WHEN THE CLAIMED DEFECTIVE PRODUCT WAS USED; AND (b) THE CLAIMED DEFECTIVE PRODUCT AND A COPY OF THE PURCHASE INVOICE IS RETURNED TO TLV, FREIGHT AND TRANSPORTATION COSTS PREPAID, UNDER A RETURN MATERIAL AUTHORIZATION AND TRACKING NUMBER ISSUED BY TLV. ALL LABOR COSTS, SHIPPING COSTS, AND TRANSPORTATION COSTS ASSOCIATED WITH THE RETURN OR REPLACEMENT OF THE CLAIMED DEFECTIVE PRODUCT ARE SOLELY THE RESPONSIBILITY OF BUYER OR THE FIRST END USER. TLV RESERVES THE RIGHT TO INSPECT ON THE FIRST END USER’S SITE ANY PRODUCTS CLAIMED TO BE DEFECTIVE BEFORE ISSUING A RETURN MATERIAL AUTHORIZATION. SHOULD SUCH INSPECTION REVEAL, IN TLV’S REASONABLE DISCRETION, THAT THE

CLAIMED DEFECT IS NOT COVERED BY THIS WARRANTY, THE PARTY ASSERTING THIS WARRANTY SHALL PAY TLV FOR THE TIME AND EXPENSES RELATED TO SUCH ON-SITE INSPECTION.

### **Exclusion of Consequential and Incidental Damages**

IT IS SPECIFICALLY ACKNOWLEDGED THAT THIS WARRANTY, ANY OTHER EXPRESS WARRANTY NOT NEGATED HEREBY, AND ANY IMPLIED WARRANTY NOT NEGATED HEREBY, INCLUDING THE IMPLIED WARRANTIES OF MERCHANTABILITY AND FITNESS FOR A PARTICULAR PURPOSE, DO NOT COVER, AND NEITHER TLV, TII NOR TLVJ WILL IN ANY EVENT BE LIABLE FOR, INCIDENTAL OR CONSEQUENTIAL DAMAGES, INCLUDING, BUT NOT LIMITED TO LOST PROFITS, THE COST OF DISASSEMBLY AND SHIPMENT OF THE DEFECTIVE PRODUCT, INJURY TO OTHER PROPERTY, DAMAGE TO BUYER'S OR THE FIRST END USER'S PRODUCT, DAMAGE TO BUYER'S OR THE FIRST END USER'S PROCESSES, LOSS OF USE, OR OTHER COMMERCIAL LOSSES. WHERE, DUE TO OPERATION OF LAW, CONSEQUENTIAL AND INCIDENTAL DAMAGES UNDER THIS WARRANTY, UNDER ANY OTHER EXPRESS WARRANTY NOT NEGATED HEREBY OR UNDER ANY IMPLIED WARRANTY NOT NEGATED HEREBY (INCLUDING THE IMPLIED WARRANTIES OF MERCHANTABILITY AND FITNESS FOR A PARTICULAR PURPOSE) CANNOT BE EXCLUDED, SUCH DAMAGES ARE EXPRESSLY LIMITED IN AMOUNT TO THE PURCHASE PRICE OF THE DEFECTIVE PRODUCT. THIS EXCLUSION OF CONSEQUENTIAL AND INCIDENTAL DAMAGES, AND THE PROVISION OF THIS WARRANTY LIMITING REMEDIES HEREUNDER TO REPLACEMENT, ARE INDEPENDENT PROVISIONS, AND ANY DETERMINATION THAT THE LIMITATION OF REMEDIES FAILS OF ITS ESSENTIAL PURPOSE OR ANY OTHER DETERMINATION THAT EITHER OF THE ABOVE REMEDIES IS UNENFORCEABLE, SHALL NOT BE CONSTRUED TO MAKE THE OTHER PROVISIONS UNENFORCEABLE.

### **Exclusion of Other Warranties**

THIS WARRANTY IS IN LIEU OF ALL OTHER WARRANTIES, EXPRESS OR IMPLIED, AND ALL OTHER WARRANTIES, INCLUDING BUT NOT LIMITED TO THE IMPLIED WARRANTIES OF MERCHANTABILITY AND FITNESS FOR A PARTICULAR PURPOSE, ARE EXPRESSLY DISCLAIMED.

### **Severability**

Any provision of this warranty which is invalid, prohibited or unenforceable in any jurisdiction shall, as to such jurisdiction, be ineffective to the extent of such invalidity, prohibition or unenforceability without invalidating the remaining provisions hereof, and any such invalidity, prohibition or unenforceability in any such jurisdiction shall not invalidate or render unenforceable such provision in any other jurisdiction.

## **TLV CORPORATION**

13901 South Lakes Drive, Charlotte, NC 28273-6790, U.S.A.

Tel: [1]-704-597-9070

Fax: [1]-704-583-1610



---

**Manufacturer: TLV<sup>®</sup> CO., LTD.**  
881 Nagasuna, Noguchi, Kakogawa,  
Hyogo 675-8511, **Japan**

Tel: [81]-(0)79-427-1800  
Fax: [81]-(0)79-422-2277

---

Printed on recycled paper.