

INSTRUCTION MANUAL

TLV Clean Steam Trap P10

Thank you for purchasing the **TLV** thermodynamic disc steam trap P10 for clean steam use.

This product has been thoroughly inspected before being shipped from the factory. When the product is delivered, before doing anything else, check the specifications and external appearance to make sure nothing is out of the ordinary. Before beginning installation or maintenance, please read this manual to ensure correct usage of the product.

This instruction manual is needed not only for installation, but for subsequent troubleshooting. Please keep it in a safe place for future reference.

The contents of this manual are subject to change without notice.

1. Safety Considerations

Installation, inspection, maintenance, repairs, disassembly, and adjustment should be done only by trained maintenance personnel.



| | |
|--|--|
| | <p>DO NOT use this product outside the recommended operating pressure, temperature and other specification ranges. Improper use may result in such hazards as damage to the product or malfunctions which may lead to serious accidents. Local regulations may restrict the use of this product to below the conditions quoted.</p> |
| | <p>Take measures to prevent people from coming into direct contact with product outlets. Failure to do so may result in burns or other injury from the discharge of fluids.</p> |
| | <p>When disassembling or removing the product, wait until the internal pressure equals atmospheric pressure and the surface of the product has cooled to room temperature. Disassembling or removing the product when it is hot or under pressure may lead to discharge of fluids, causing burns, other injuries or damage.</p> |
| | <p>Be sure to use only the recommended components when repairing the product, and NEVER attempt to modify the product in any way. Failure to observe these precautions may result in damage to the product and burns or other injury due to malfunction or the discharge of fluids.</p> |
| | <p>Use only under conditions in which no freeze-up will occur. Freezing may damage the product, leading to fluid discharge, which may cause burns or other injury</p> |
| | <p>Use only under conditions in which no water hammer will occur. The impact of water hammer may damage the product, leading to fluid discharge, which may cause burns or other injury.</p> |

2. Specifications

Refer to the product nameplate for detailed specifications.

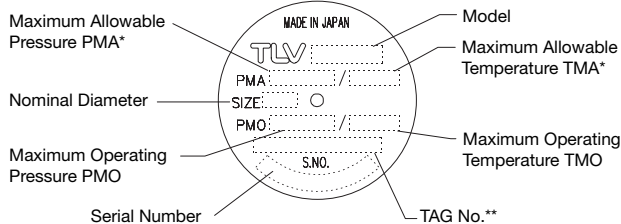

| | |
|---|--|
| Minimum Operating Pressure (MpaG / barg / psig) | Horizontally installed: 0.025 / 0.25 / 3.5 Vertically installed: 0.04 / 0.4 / 6 |
| Maximum Back Pressure | 80 % of Inlet Pressure |

* Maximum allowable pressure (PMA) and maximum allowable temperature (TMA) are PRESSURE SHELL DESIGN CONDITIONS (**NOT** OPERATING CONDITIONS)

** TAG No. is displayed for products with options. This item is omitted from the nameplate when there are no options

3. Configuration

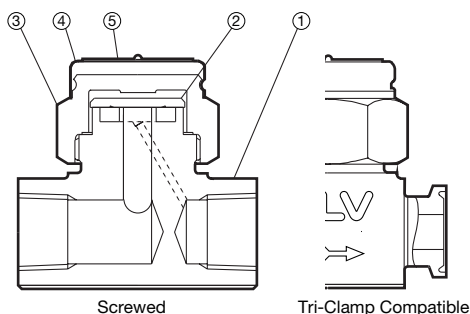

| No. | Name |
|-----|-----------|
| 1 | Body |
| 2 | Disc |
| 3 | Cover |
| 4 | Cap |
| 5 | Nameplate |

4. Proper Installation

- Before installation, be sure to remove all protective seals from the product.
- Before installing the product, blow out the inlet piping to remove all dirt and oil.
- Install with the arrow on the product pointing in the direction of flow.
- The product can be installed in any position; there are no restrictions on the direction of installation.
- Open the inlet valve, and make sure that the product operates properly.
- If there is a problem, see "Troubleshooting".

Operational Inspection:

A visual inspection of the following items should be done on a daily basis to determine whether the product is operating properly or has failed. Periodically (at least biannually) the operation should also be checked by using diagnostic equipment, such as a stethoscope, TLV PenCheck or TLV TrapMan. (Inspection, installation, maintenance, repairs, disassembly, and adjustment should be done only by trained maintenance personnel.) Product failure could cause damage to piping and equipment, resulting in faulty or low quality products.

| | |
|--------------------------------|---|
| Normal Operation | Condensate and flash steam are discharged intermittently, accompanied by the powerful rushing sound of flow. |
| Blocked (discharge impossible) | No condensate is discharged. The trap is quiet and makes no noise, and the surface temperature of the trap is low. |
| Blowing | Live steam continuously flows from the outlet and there is a continuous piercing metallic sound. |
| Steam Leakage | Live steam is discharged through the outlet together with the condensate and there is a high-pitched hissing sound. |
| Chattering | The trap does not close properly. Steam is discharged from the trap in short rapid bursts. |

Parts Inspection Procedure:

When parts have been removed, or during periodic inspections, use the following table to inspect the parts, and replace any that are found to be defective.

| | |
|----------------------------|--|
| Disc | Check for damage or wear |
| Body | Check inside for damage, dirt, rust or scale |
| Valve Seating Area on Body | Check for damage or wear |

6. Disassembly / Reassembly

Use the following procedures to remove components. Use the same procedures in reverse to reassemble.

| Part | During Disassembly | During Reassembly |
|-------|---|--|
| Cover | Remove with a 38 mm (1 1/2 ") socket wrench | Coat threads with anti-seize* and tighten to 120 N·m (88 ft·lb) |
| Disc | Remove, being careful not to scratch the lapped surface | Make sure the seat surface (the lapped side with a groove) is facing down, toward valve seat |

* Recommend use of Bostic® Never-Seez® White Food Grade with PTFE (meets USDA and FDA CRF-178.3570)

NOTE: If drawings or other documentation were supplied for the product, any torque given there takes precedence over values shown here.

7. Troubleshooting

| Problem | Cause | Remedy |
|--|---|--|
| No condensate is discharged (blocked) or discharge is poor | On-body valve seat or piping is clogged with foreign matter | Clean parts |
| | Disc is stuck to on-body valve seat | Clean parts |
| | Air-locking has occurred | Perform bypass blowdown |
| | Steam-locking has occurred | Perform bypass blowdown, or close inlet valve and allow the trap to cool |
| Steam is discharged or leaks from the outlet (blowing) (steam leakage) | Operating pressure exceeds maximum specified pressure, or pressure differential between trap inlet & outlet is insufficient | Compare specifications and actual operating conditions |
| | Foreign matter has settled on the disc or on the on-body valve seat | Clean parts |
| | Disc is damaged or worn | Replace the disc |
| | On-body valve seat is damaged or worn | Replace the body |
| | Improper installation | Correct the installation |
| Steam leaking from sealing area | Trap vibration occurs | Lengthen inlet piping and fasten it securely |
| | Trap operating pressure is less than the minimum specified pressure | Compare specifications and actual operating conditions |
| | Improper tightening torque was used | Tighten to the proper torque |

8. Product Warranty

- Warranty Period: One year following product delivery.
- TLV CO., LTD. warrants this product to the original purchaser to be free from defective materials and workmanship. Under this warranty, the product will be repaired or replaced at our option, without charge for parts or labor.
- This product warranty will not apply to cosmetic defects, nor to any product whose exterior has been damaged or defaced; nor does it apply in the following cases:
 - Malfunctions due to improper installation, use, handling, etc., by other than TLV CO., LTD. authorized service representatives.
 - Malfunctions due to dirt, scale, rust, etc.
 - Malfunctions due to improper disassembly and reassembly, or inadequate inspection and maintenance by other than TLV CO., LTD. authorized service representatives.
 - Malfunctions due to disasters or forces of nature.
 - Accidents or malfunctions due to any other cause beyond the control of TLV CO., LTD.
- Under no circumstances will TLV CO., LTD. be liable for consequential economic loss or damage or consequential damage to property.

For Service or Technical Assistance:

Contact your **TLV** representative or your **TLV** office for North America:
TLV CORPORATION Tel. [1]-704-597-9070

Manufacturer:

TLV CO., LTD.

881 Nagasuna, Noguchi, Kakogawa, Hyogo, 675-8511 Japan
 Tel: [81]-0)794-22-1122 Fax: [81]-0)794-22-0112