



Manufacturer

TLV CO., LTD.
Kakogawa, Japan

is approved by LRDA Ltd. to ISO 9001/14001



Instruction Manual

Air Trap **TATSU2**

Manufacturer

TLV CO., LTD.

881 Nagasuna, Noguchi, Kakogawa, Hyogo, 675-8511, Japan

Tel: [81]-(0)79-422-1122 Fax: [81]-(0)79-422-0112

Copyright © 2021 by TLV CO., LTD. All rights reserved

TLV CORPORATION

Contents

Introduction	1
Safety Considerations	2
Operation	4
Specifications	5
Configuration	5
Installation	6
Maintenance	7
The Need for a Pressure-balancing Line	8
Disassembly/Reassembly	9
Troubleshooting	10

TLV EXPRESS LIMITED WARRANTYエラー! ブックマークが定義され

Introduction

Thank you for purchasing the TLV air trap.

This product has been thoroughly inspected before being shipped from the factory. When the product is delivered, before doing anything else, check the specifications and external appearance to make sure nothing is out of the ordinary. Also be sure to read this manual carefully before use and follow the instructions to be sure of using the product properly.

This air trap automatically drains high viscosity oil and condensate from air and gas lines and receiver tanks. Its unique design allows self-cleaning of the trap interior during each discharge cycle, and the large size orifice eliminates problems due to dirt and oil accumulation.







If detailed instructions for special order specifications or options not contained in this manual are required, please contact TLV for full details.

This instruction manual is intended for use with the model(s) listed on the front cover. It is necessary not only for installation but for subsequent, maintenance, disassembly/reassembly and troubleshooting. Please keep it in a safe place for future reference.

Safety Considerations

- Read this section carefully before use and be sure to follow the instructions.
- Installation, inspection, maintenance, repairs, disassembly, adjustment and valve opening/closing should be carried out only by trained maintenance personnel.
- The precautions listed in this manual are designed to ensure safety and prevent equipment damage and personal injury. For situations that may occur as a result of erroneous handling, three different types of cautionary items are used to indicate the degree of urgency and the scale of potential damage and danger: DANGER, WARNING and CAUTION.
- The three types of cautionary items above are very important for safety: be sure to observe all of them as they relate to installation, use, maintenance, and repair. Furthermore, TLV accepts no responsibility for any accidents or damage occurring as a result of failure to observe these precautions.

Symbols

	Indicates a DANGER, WARNING or CAUTION item.
	Indicates an urgent situation which poses a threat of death or serious injury
	Indicates that there is a potential threat of death or serious injury
	Indicates that there is a possibility of injury or equipment/product damage
	<p>NEVER apply direct heat to the float.</p> <p>The float may explode due to increased internal pressure, causing accidents leading to serious injury or damage to property and equipment.</p>
	<p>Install properly and DO NOT use this product outside the recommended operating pressure, temperature and other specification ranges.</p> <p>Improper use may result in such hazards as damage to the product or malfunctions that may lead to serious accidents. Local regulations may restrict the use of this product to below the conditions quoted.</p> <p>DO NOT use the product in excess of the maximum operating pressure differential.</p> <p>Such use could make discharge impossible (blocked).</p> <p>Use hoisting equipment for heavy objects (weighing approximately 20 kg (44 lb) or more).</p> <p>Failure to do so may result in back strain or other injury if the object should fall.</p> <p>Take measures to prevent people from coming into direct contact with product outlets.</p> <p>Failure to do so may result in burns or other injury from the discharge of fluids.</p>

Continued on the next page

 CAUTION	<p>When disassembling or removing the product, wait until the internal pressure equals atmospheric pressure and the surface of the product has cooled to room temperature.</p> <p>Disassembling or removing the product when it is hot or under pressure may lead to discharge of fluids, causing burns, other injuries or damage.</p>
	<p>Be sure to use only the recommended components when repairing the product, and NEVER attempt to modify the product in any way.</p> <p>Failure to observe these precautions may result in damage to the product and burns or other injury due to malfunction or the discharge of fluids.</p>
	<p>Do not use excessive force when connecting threaded pipes to the product.</p> <p>Over-tightening may cause breakage leading to fluid discharge, which may cause burns or other injury.</p>
	<p>Use only under conditions in which no freeze-up will occur.</p> <p>Freezing may damage the product, leading to fluid discharge, which may cause burns or other injury.</p>

Operation

Principles of condensate discharge

1. Condensate and oil flow into and accumulate in the trap.

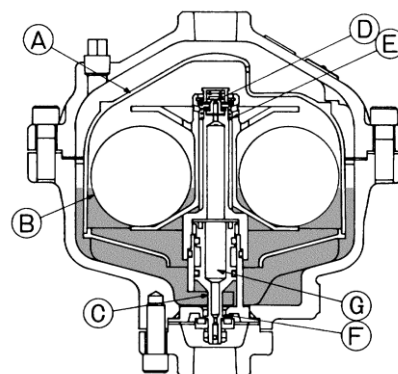

2. When the condensate level in the trap body rises to a certain point, the floats (B) rise. This, together with the help of the coil spring (E), lifts the float holder, causing the pilot valve (D) to open.

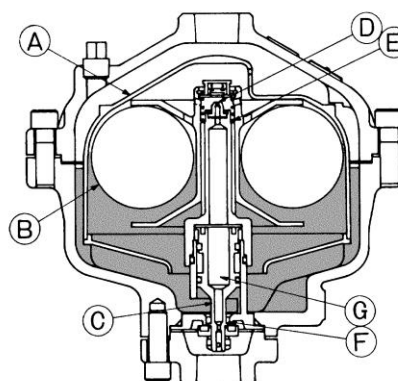

3. When the pilot valve (D) opens, compressed air (primary side) enters the pressure chamber (G) and pushes the piston (C) down, opening the main orifice (F) to discharge condensate and oil. The pressure inside the float cover (A) is lower than that outside, so the condensate outside the float cover discharges first, after which the condensate inside the float cover discharges. As the condensate inside the float cover discharges, some pressurized air will discharge with the condensate to flush out any oil or dirt in the trap and provide a self cleaning action.

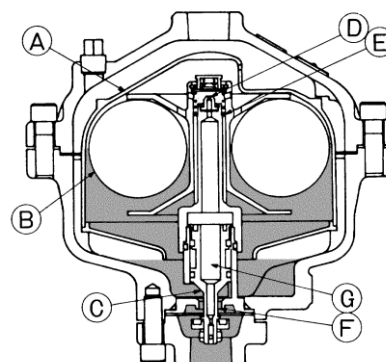

4. When the condensate has been discharged, the floats (B) fall, causing the pilot valve orifice (D) to close. When the pilot valve orifice (D) closes, the pressure in the pressure chamber (G) is released to the outlet and the piston (C) rises to close the main valve orifice (F).

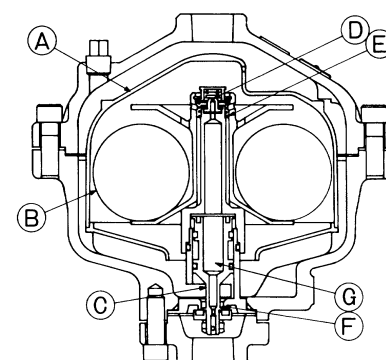

Note: In this manner, inflowing condensate is intermittently discharged.

Specifications



Install properly and **DO NOT** use this product outside the recommended operating pressure, temperature and other specification ranges. Improper use may result in such hazards as damage to the product or malfunctions which may lead to serious accidents. Local regulations may restrict the use of this product to below the conditions quoted.



DO NOT use the product in excess of the maximum operating pressure differential; such use could make discharge impossible (blocked).



Use only under conditions in which no freeze-up will occur. Freezing may damage the product, leading to fluid discharge, which may cause burns or other injury.

Refer to the product nameplate for detailed specifications.

Minimum operating pressure:
0.2 MPaG (30 psig)

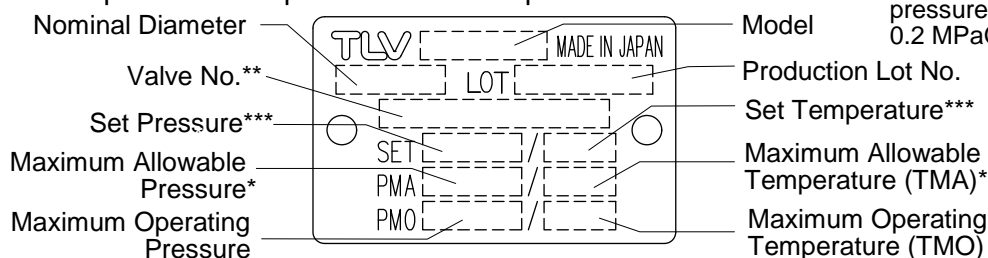

*Maximum allowable pressure (PMA) and maximum allowable temperature (TMA) are **PRESSURE SHELL DESIGN CONDITIONS, NOT OPERATING CONDITIONS.**

**Valve No. is displayed for products with options. This item is omitted from the nameplate when there are no options.

Configuration

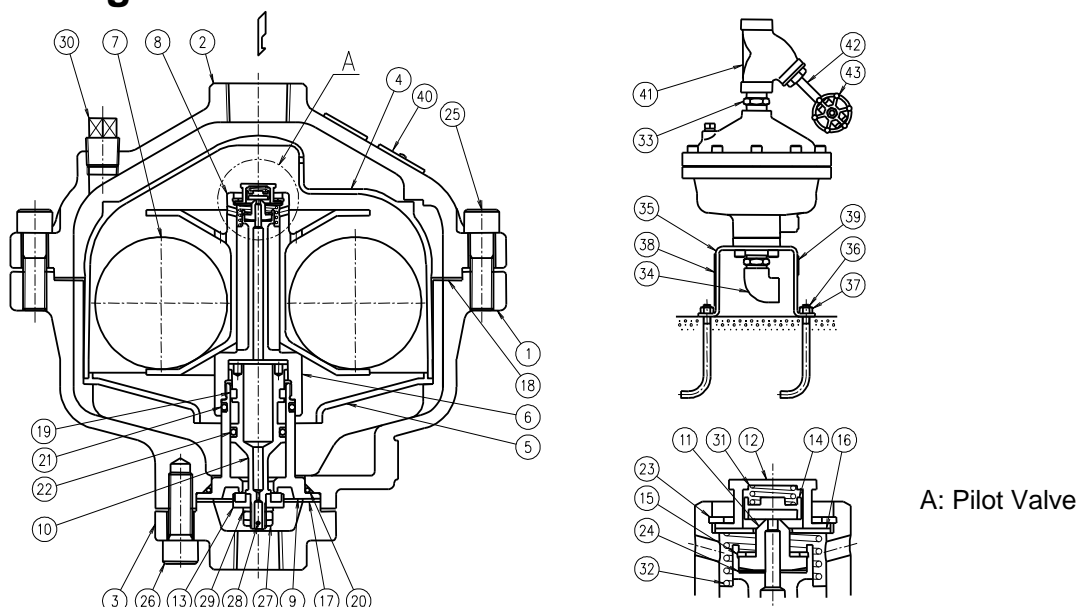

No.	Name	No.	Name	No.	Name	No.	Name	No.	Name
1	Body	10	Piston	18	Cover Gasket	28	Split Pin	37	Anchor Nut
2	Cover	11	Pilot Valve Seat	19	Slide Ring	29	Spring Washer	38	Caution Faceplate
3	Outlet Union	12	Spring Holder	20	Main Valve O-Ring	30	Balancing Line Plug	39	Caution Faceplate
4	Float Cover	13	Main Valve	21	Piston Guide O-Ring	31	Sealing Spring	40	Nameplate
5	Bottom Plate	14	Pilot Valve	22	Piston O-Ring	32	Opening Spring	41	Y-Strainer
6	Piston Guide	15	Snap Ring	23	Snap Ring	33	Nipple	42	Pipe
7	Float	16	Pilot Valve Support Plate	24	Valve Seat Gasket	34	Elbow	43	Globe Valve
8	Float Holder	17	Outlet Union Gasket	25	Cover Bolt	35	Mounting Base		
9	Main Valve Seat			26	Outlet Union Bolt	36	Anchor Bolt		
				27	Castle Nut				

Installation



Install properly and **DO NOT** use this product outside the recommended operating pressure, temperature and other specification ranges. Improper use may result in such hazards as damage to the product or malfunctions which may lead to serious accidents. Local regulations may restrict the use of this product to below the conditions quoted.



Use hoisting equipment for heavy objects (weighing approximately 20 kg (44 lb) or more). Failure to do so may result in back strain or other injury if the object should fall.



Take measures to prevent people from coming into direct contact with product outlets. Failure to do so may result in burns or other injury from the discharge of fluids.



Do not use excessive force when connecting threaded pipes to the product. Over-tightening may cause breakage leading to fluid discharge, which may cause burns or other injury.

Installation, inspection, maintenance, repairs, disassembly, adjustment and valve opening/closing should be carried out only by trained maintenance personnel.

1. Before installing the product, blow out the inlet piping to remove any piping scraps, dirt and oil. Close the inlet valve after blowdown.
2. Before installation, be sure to remove all protective seals.
3. Using the nipple, attach the Y-strainer to the inlet of the TATSU2 cover.
4. Install the product so that the arrow on the body is pointing in the direction of condensate flow.
5. Install the product with the trap body oriented vertically. The product should be inclined no more than 10° horizontally and front-to-back.
6. Install the product in the lowest part of the pipeline or equipment so that condensate flows naturally into the trap by gravity. The outlet connection piping should be 25 mm (1 in) or greater. If the nominal diameter is less than 25 mm (1 in), condensate flow will be restricted and adequate product performance cannot be achieved.
7. To ensure proper condensate flow into the trap, remove the balancing line plug and install a pressure-balancing line. Connect the end of the pressure-balancing line to the air main or an area with an air pocket. For more details, see the section "The Need for a Pressure-balancing Line".
8. If the compressor vibrates heavily, secure the product in place using anchor bolts.

If there is a problem, determine the cause using the "Troubleshooting" section in this manual.

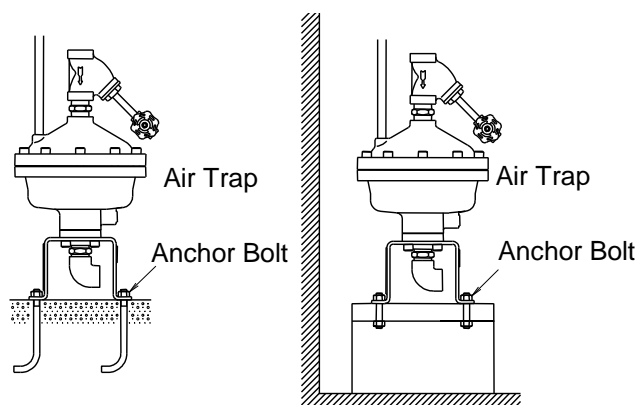

Allowable angles of inclination for installation

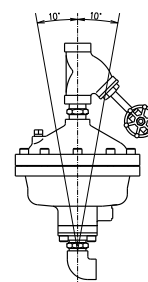

Maintenance



Take measures to prevent people from coming into direct contact with product outlets. Failure to do so may result in burns or other injury from the discharge of fluids.



Be sure to use only the recommended components when repairing the product, and NEVER attempt to modify the product in any way. Failure to observe these precautions may result in damage to the product or burns or other injury due to malfunction or the discharge of fluids.

Operational Check

A visual inspection of the following items should be done on a daily basis to determine whether the product is operating properly or has failed. Periodically (at least biannually) the operation should also be checked by using diagnostic equipment such as a stethoscope.

If the product should fail, it may cause damage to piping and equipment, resulting in faulty or low quality products or losses due to leakage.

- Normal : When condensate accumulates inside the body, the valve opens and the sound of flow can be heard as the condensate discharges. The sound of air being discharged can then be heard, after which the valve closes. This cycle repeats.
- Blocked (Discharge Impossible) : A long time passes with no condensate discharged (no sound of flow, no discharge cycle is heard).
- Blowing : A large quantity of air continually flows from the outlet and there is a loud blowing sound.
- Air Leakage : When the trap valve is closed, a small amount of air is discharged through the trap outlet together with condensate, accompanied by a high-pitched hissing sound.

Parts Inspection

When parts have been removed, or during periodic inspections, use the following table to inspect the parts and replace any that are found to be defective.

Procedure
Gasket(s): Check for warping and damage
Screen: Check for clogging and corrosion
Floats: Check for deformation
Spring Holder: Check for dirt or a dirty coating
O-ring: Check for warping and damage
Pilot Valve Seat: Check for dirt, wear and damage
Surfaces that Seat with Pilot Valve: check for dirt, wear and damage
Main Valve: Check dirt, oil film, wear and damage

The Need for a Pressure-balancing Line

This air trap is designed to automatically and intermittently discharge inflowing condensate. However, if the condensate completely fills the inlet path to the trap, air in the trap body will not be able to escape, preventing displacement by condensate, and thus preventing condensate from entering the trap. This phenomenon is called air binding. A pressure-balancing line installed between the trap cover and the dry portion of the receiver tank is used to prevent this phenomenon from occurring.

Connect the pressure-balancing line in the following manner:

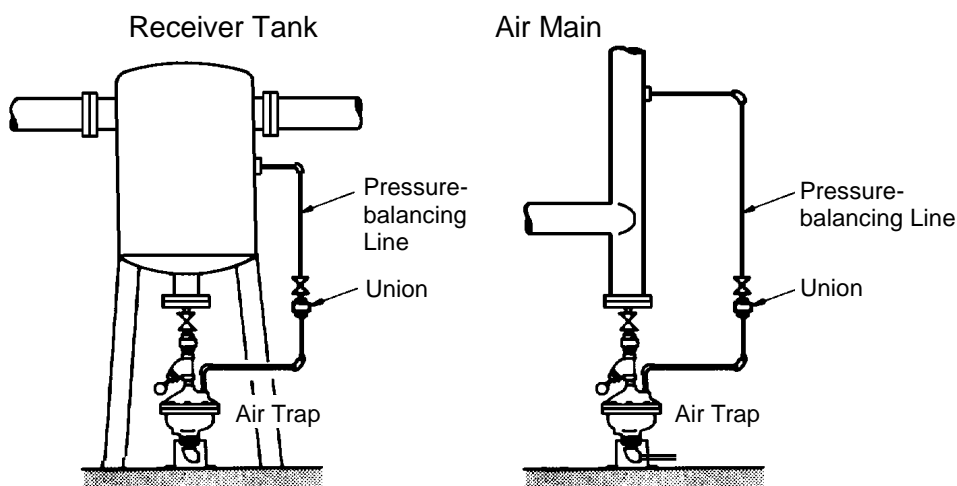

Note: Be sure to connect the pressure-balancing line to an area with the same pressure or to an air section downstream of the flow medium.

Disassembly/Reassembly



NEVER apply direct heat to the float. The float may explode due to increased internal pressure, causing accidents leading to serious injury or damage to property and equipment.



Use hoisting equipment for heavy objects (weighing approximately 20 kg (44 lb) or more). Failure to do so may result in back strain or other injury if the object should fall.



When disassembling or removing the product, wait until the internal pressure equals atmospheric pressure and the surface of the product has cooled to room temperature. Disassembling or removing the product when it is hot or under pressure may lead to discharge of fluids, causing burns, other injuries or damage.

Use the following procedures to remove components. Use the same procedures in reverse to reassemble. (Installation, inspection, maintenance, repairs, disassembly, adjustment and valve opening/closing should be carried out only by trained maintenance personnel.)

Disassembly / Reassembly Procedure

NOTE: Disconnect any lines that must be disconnected before disassembly can take place (inlet piping, pressure-balancing line, condensate discharge piping, etc.). Remove the anchor bolts and move to an open space or work bench for disassembly.

Part	During Disassembly	During Reassembly
Y-Strainer	Remove with a wrench	Wrap threads on nipple with 3 – 3.5 turns of sealing tape; reattach
Cover Bolts	Remove with an allen wrench	Consult the table of tightening torques and tighten to the proper torque
Cover	Lift off of the body	Set gently on the body
Cover Gasket	Remove the gasket and clean sealing surfaces	Replace with a new gasket
Float Cover	lift off of the bottom plate	Set on the bottom plate's grooved track
Float Holder	Lift straight off of the guide; be careful not to drop the floats	Slide onto the guide being careful not to drop the floats
Floats	Remove, being careful not to scratch the polished surface	Insert carefully, taking care not to scratch the polished surface
Bottom Plate	Lift off of grooved shelf in body	Set on grooved shelf in body
Outlet Union Bolts	Remove with a hex key	Consult the table of tightening torques and tighten to the proper torque
Mounting Base	Take off of the outlet union	Place on the outlet union and align bolt holes
Outlet Union	Remove from the body being careful not to damage the piston or main valve;	Align and reattach to the body
Outlet Union Gasket	Remove the gasket and clean sealing surfaces	Replace with a new gasket
Piston Unit (Piston, Piston Guide, Piston Valve Seat)	Carefully remove from the body; no further disassembly is advised	This unit should be considered one part; in times of malfunction, all parts should be replaced together

Torque Tightening Table

Part	Torque		Distance Across Flats	
	(N·m)	(lbf·ft)	(mm)	(in)
Cover Bolt	70	(51)	10	(³ / ₈)
Outlet Union Bolt	50	(37)	10	(³ / ₈)

(1 N·m ≈ 10 kg·cm)

Troubleshooting



WARNING

NEVER apply direct heat to the float. The float may explode due to increased internal pressure, causing accidents leading to serious injury or damage to property and equipment.



CAUTION

When disassembling or removing the product, wait until the internal pressure equals atmospheric pressure and the surface of the product has cooled to room temperature. Disassembling or removing the product when it is hot or under pressure may lead to discharge of fluids, causing burns, other injuries or damage.

When the product fails to operate properly during operation, first confirm the following items:

1. Make sure that there is pressure at the trap inlet, and that the pressure is within the correct operating range. (Operating pressure range: 0.2 to 1.0 MPaG (30 to 150 psig))
2. Check to make sure that the pressure-balancing line is correctly installed.
3. Make sure that condensate is flowing into the trap. Lastly, make sure that the piping is configured in a way that allows condensate to flow freely into the trap.

When the product fails to operate properly, use the following table to locate the cause and remedy.

Problem	Cause	Remedy
No condensate is discharged (blocked) or discharge is poor	The pilot valve seat is clogged with scale	Clean parts
	There is a build-up of scale between the piston and the main valve seat	Clean parts
	There is a build-up of rust or scale between the float holder and the piston guide	Clean parts
	The trap has the wrong number of floats (requires 4), or the floats are damaged or full of condensate	Inspect and replace if necessary
	The vent hole in the float cover is clogged with rust and scale	Clean parts
	The pressure-balancing line is clogged with rust and scale	Clean parts
	The opening spring is broken	Inspect and replace if necessary
Air and/or condensate leaks from the outlet between discharge cycles (air leakage)	Scale has built up on the pilot valve seat or valve or the seating surfaces are scratched, crushed or worn	Clean or replace parts*
	Scale has built up on the main valve seat or main valve or the seating surfaces are scratched, crushed or worn	Clean or replace parts*
	The trap is subjected to direct heavy vibration from the compressor	Inspect and anchor if necessary
	The sealing surfaces of an O-ring are scratched or damaged	Inspect and replace if necessary*
Air is blowing and the valve does not close (blowing)	There is a build-up of sticky scale between the float holder and the piston guide	Clean parts
	The orifice of the piston is clogged with scale	Clean parts
	Scale has built up on the pilot valve seat	Clean parts
	The sealing spring is broken	Inspect and replace if necessary
Air is leaking from a place other than the outlet	Gasket deterioration or damage	Replace with new gasket(s)
	Improper tightening torques were used	Tighten to the proper torque

* The Piston Unit (Piston, Piston Guide, Piston Valve Seat) should be considered one part; in times of malfunction, all parts should be replaced together

TLV EXPRESS LIMITED WARRANTY

Subject to the limitations set forth below, TLV Corporation, a North Carolina corporation (“**TLV**”) warrants that products which are sold by it, TLV CO., LTD., a Japanese corporation (“**TLVJ**”) or TLV International, Inc., a Japanese corporation (“**TII**”), (hereinafter the “**Products**”) are designed and manufactured by TLVJ, conform to the specifications published by TLV for the corresponding part numbers (the “**Specifications**”) and are free from defective workmanship and materials. With regard to products or components manufactured by unrelated third parties (the “**Components**”), TLV provides no warranty other than the warranty from the third party manufacturer(s), if any.

Exceptions to Warranty

This warranty does not cover defects or failures caused by:

1. improper shipping, installation, use, handling, etc., by other than TLV or service representatives authorized by TLV; or
2. dirt, scale or rust, etc.; or
3. improper disassembly and reassembly, or inadequate inspection and maintenance by other than TLV or service representatives authorized by TLV; or
4. disasters or forces of nature or Acts of God; or
5. abuse, abnormal use, accidents or any other cause beyond the control of TLV; or
6. improper storage, maintenance or repair; or
7. operation of the Products not in accordance with instructions issued with the Products or with accepted industry practices; or
8. use for a purpose or in a manner for which the Products were not intended; or
9. use of the Products in a manner inconsistent with the Specifications; or
10. use of the Products with Hazardous Fluids (fluids other than steam, air, water, nitrogen, carbon dioxide and inert gases (helium, neon, argon, krypton, xenon and radon)); or
11. failure to follow the instructions contained in the TLV Instruction Manual for the Product.

Duration of Warranty

This warranty is effective for a period of the earlier of: (i) three (3) years after delivery of Products to the first end user in the case of sealed SST-Series Products for use in steam pressure service up to 650 psig; (ii) two (2) years after delivery of Products to the first end user in the case of PowerTrap® units; or (iii) one (1) year after delivery of Products to the first end user in the case of all other Products. Notwithstanding the foregoing, asserting a claim under this warranty must be brought by the earlier of one of the foregoing periods, as applicable, or within five (5) years after the date of delivery to the initial buyer if not sold initially to the first end user.

ANY IMPLIED WARRANTIES NOT NEGATED HEREBY WHICH MAY ARISE BY OPERATION OF LAW, INCLUDING THE IMPLIED WARRANTIES OF MERCHANTABILITY AND FITNESS FOR A PARTICULAR PURPOSE AND ANY EXPRESS WARRANTIES NOT NEGATED HEREBY, ARE GIVEN SOLELY TO THE INITIAL BUYER AND ARE LIMITED IN DURATION TO ONE (1) YEAR FROM THE DATE OF SHIPMENT BY TLV.

Exclusive Remedy

THE EXCLUSIVE REMEDY UNDER THIS WARRANTY, UNDER ANY EXPRESS WARRANTY OR UNDER ANY IMPLIED WARRANTIES NOT NEGATED HEREBY (INCLUDING THE IMPLIED WARRANTIES OF MERCHANTABILITY AND FITNESS FOR A PARTICULAR PURPOSE), IS **REPLACEMENT**; PROVIDED: (a) THE CLAIMED DEFECT IS REPORTED TO TLV IN WRITING WITHIN THE APPLICABLE WARRANTY PERIOD, INCLUDING A DETAILED WRITTEN DESCRIPTION OF THE CLAIMED DEFECT AND HOW AND WHEN THE CLAIMED DEFECTIVE PRODUCT WAS USED; AND (b) THE CLAIMED DEFECTIVE

PRODUCT AND A COPY OF THE PURCHASE INVOICE IS RETURNED TO TLV, FREIGHT AND TRANSPORTATION COSTS PREPAID, UNDER A RETURN MATERIAL AUTHORIZATION AND TRACKING NUMBER ISSUED BY TLV. ALL LABOR COSTS, SHIPPING COSTS, AND TRANSPORTATION COSTS ASSOCIATED WITH THE RETURN OR REPLACEMENT OF THE CLAIMED DEFECTIVE PRODUCT ARE SOLELY THE RESPONSIBILITY OF BUYER OR THE FIRST END USER. TLV RESERVES THE RIGHT TO INSPECT ON THE FIRST END USER'S SITE ANY PRODUCTS CLAIMED TO BE DEFECTIVE BEFORE ISSUING A RETURN MATERIAL AUTHORIZATION. SHOULD SUCH INSPECTION REVEAL, IN TLV'S REASONABLE DISCRETION, THAT THE CLAIMED DEFECT IS NOT COVERED BY THIS WARRANTY, THE PARTY ASSERTING THIS WARRANTY SHALL PAY TLV FOR THE TIME AND EXPENSES RELATED TO SUCH ON-SITE INSPECTION.

Exclusion of Consequential and Incidental Damages

IT IS SPECIFICALLY ACKNOWLEDGED THAT THIS WARRANTY, ANY OTHER EXPRESS WARRANTY NOT NEGATED HEREBY, AND ANY IMPLIED WARRANTY NOT NEGATED HEREBY, INCLUDING THE IMPLIED WARRANTIES OF MERCHANTABILITY AND FITNESS FOR A PARTICULAR PURPOSE, DO NOT COVER, AND NEITHER TLV, TII NOR TLVJ WILL IN ANY EVENT BE LIABLE FOR, INCIDENTAL OR CONSEQUENTIAL DAMAGES, INCLUDING, BUT NOT LIMITED TO LOST PROFITS, THE COST OF DISASSEMBLY AND SHIPMENT OF THE DEFECTIVE PRODUCT, INJURY TO OTHER PROPERTY, DAMAGE TO BUYER'S OR THE FIRST END USER'S PRODUCT, DAMAGE TO BUYER'S OR THE FIRST END USER'S PROCESSES, LOSS OF USE, OR OTHER COMMERCIAL LOSSES. WHERE, DUE TO OPERATION OF LAW, CONSEQUENTIAL AND INCIDENTAL DAMAGES UNDER THIS WARRANTY, UNDER ANY OTHER EXPRESS WARRANTY NOT NEGATED HEREBY OR UNDER ANY IMPLIED WARRANTY NOT NEGATED HEREBY (INCLUDING THE IMPLIED WARRANTIES OF MERCHANTABILITY AND FITNESS FOR A PARTICULAR PURPOSE) CANNOT BE EXCLUDED, SUCH DAMAGES ARE EXPRESSLY LIMITED IN AMOUNT TO THE PURCHASE PRICE OF THE DEFECTIVE PRODUCT. THIS EXCLUSION OF CONSEQUENTIAL AND INCIDENTAL DAMAGES, AND THE PROVISION OF THIS WARRANTY LIMITING REMEDIES HEREUNDER TO REPLACEMENT, ARE INDEPENDENT PROVISIONS, AND ANY DETERMINATION THAT THE LIMITATION OF REMEDIES FAILS OF ITS ESSENTIAL PURPOSE OR ANY OTHER DETERMINATION THAT EITHER OF THE ABOVE REMEDIES IS UNENFORCEABLE, SHALL NOT BE CONSTRUED TO MAKE THE OTHER PROVISIONS UNENFORCEABLE.

Exclusion of Other Warranties

THIS WARRANTY IS IN LIEU OF ALL OTHER WARRANTIES, EXPRESS OR IMPLIED, AND ALL OTHER WARRANTIES, INCLUDING BUT NOT LIMITED TO THE IMPLIED WARRANTIES OF MERCHANTABILITY AND FITNESS FOR A PARTICULAR PURPOSE, ARE EXPRESSLY DISCLAIMED.

Severability

Any provision of this warranty which is invalid, prohibited or unenforceable in any jurisdiction shall, as to such jurisdiction, be ineffective to the extent of such invalidity, prohibition or unenforceability without invalidating the remaining provisions hereof, and any such invalidity, prohibition or unenforceability in any such jurisdiction shall not invalidate or render unenforceable such provision in any other jurisdiction.

TLV CORPORATION

13901 South Lakes Drive, Charlotte, NC 28273-6790, U.S.A.
Tel: [1]-704-597-9070 Fax: [1]-704-583-1610