



# Instruction Manual

## Surplussing Valve **SP-COSR-16**

## Contents

Introduction .....	1
Safety Considerations .....	2
Piping .....	4
Configuration .....	6
Adjustment .....	7
Disassembly and Inspection .....	8
Regular Inspection and Maintenance.....	13
Troubleshooting .....	13
Specifications .....	16
TLV EXPRESS LIMITED WARRANTY .....	18
Service .....	20

## Introduction

Thank you for purchasing the TLV surplussing valve.

This product has been thoroughly inspected before being shipped from the factory. When the product is delivered, before doing anything else, check the specifications and external appearance to make sure nothing is out of the ordinary. Also be sure to read this manual carefully before use and follow the instructions to be sure of using the product properly.

If detailed instructions for special order specifications or options not contained in this manual are required, please contact TLV for full details.

This instruction manual is intended for use with the model(s) listed on the front cover. It is necessary not only for installation but for subsequent maintenance, disassembly/reassembly and troubleshooting. Please keep it in a safe place for future reference.

## Safety Considerations

- Read this section carefully before use and be sure to follow the instructions.
- Installation, inspection, maintenance, repairs, disassembly, adjustment and valve opening/closing should be carried out only by trained maintenance personnel.
- The precautions listed in this manual are designed to ensure safety and prevent equipment damage and personal injury. For situations that may occur as a result of erroneous handling, three different types of cautionary items are used to indicate the degree of urgency and the scale of potential damage and danger: DANGER, WARNING and CAUTION.
- The three types of cautionary items above are very important for safety: be sure to observe all of them as they relate to installation, use, maintenance, and repair. Furthermore, TLV accepts no responsibility for any accidents or damage occurring as a result of failure to observe these precautions.

## Symbols

	<b>Indicates a DANGER, WARNING or CAUTION item.</b>
	Indicates an urgent situation which poses a threat of death or serious injury
	Indicates that there is a potential threat of death or serious injury
	Indicates that there is a possibility of injury or equipment / product damage
	<p><b>Install properly and DO NOT use this product outside the recommended operating pressure, temperature and other specification ranges.</b> Improper use may result in such hazards as damage to the product or malfunctions that may lead to serious accidents. Local regulations may restrict the use of this product to below the conditions quoted.</p> <p><b>Use hoisting equipment for heavy objects (weighing approximately 20 kg (44 lb) or more).</b> Failure to do so may result in back strain or other injury if the object should fall.</p> <p><b>Take measures to prevent people from coming into direct contact with product outlets.</b> Failure to do so may result in burns or other injury from the discharge of fluids.</p> <p><b>When disassembling or removing the product, wait until the internal pressure equals atmospheric pressure and the surface of the product has cooled to room temperature.</b> Disassembling or removing the product when it is hot or under pressure may lead to discharge of fluids, causing burns, other injuries or damage.</p>

Continued on the next page

 CAUTION	<p><b>Be sure to use only the recommended components when repairing the product, and NEVER attempt to modify the product in any way.</b></p> <p>Failure to observe these precautions may result in damage to the product and burns or other injury due to malfunction or the discharge of fluids.</p>
	<p><b>Do not use excessive force when connecting threaded pipes to the product.</b></p> <p>Over-tightening may cause breakage leading to fluid discharge, which may cause burns or other injury.</p>
	<p><b>Use only under conditions in which no freeze-up will occur.</b></p> <p>Freezing may damage the product, leading to fluid discharge, which may cause burns or other injury.</p>
	<p><b>Use only under conditions in which no water hammer will occur.</b></p> <p>The impact of water hammer may damage the product, leading to fluid discharge, which may cause burns or other injury.</p>

## Piping

Install the product as follows:

### Blowdown

Before installing the product, be sure to blow down all piping thoroughly. If this is not possible, use a bypass valve. Blowdown is especially important for newly installed piping or after the system has been shut down for a long period of time.

Blowdown  
(before installation)



Blowdown  
(using bypass valve)  
SP-COSR

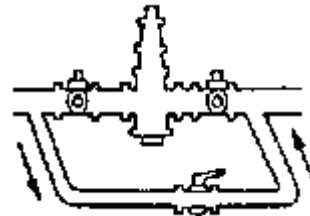

### Removing the Seals and Caps

Before installation, remove the dust seals and caps covering the apertures on the main body (on the inlet and outlet).

### Installing Spacers

When spacing adjustment is required to accommodate installation, install the spacer on the outlet flange. The spacer should consist of a spacer, gaskets, nuts and bolts. Fit the gaskets on both sides of the spacer between the product outlet and the pipe flange. Fasten with the bolts and nuts.

### Piping Supports

When installing the product, make sure it will not be subjected to excessive load, bending or vibration. We recommend that you support the inlet and outlet pipes securely.

### Clearance (Withdrawal Distance)

Be sure to leave sufficient space for maintenance, inspection and repair. Refer to the product nameplate for detailed specifications.

## Piping for Safety

Using a hex wrench, remove the vent plug and then use the coupler provided with the valve to attach a pipe leading to a safe location. This should be done so that people nearby will not be burned even if the diaphragm should break and allow steam or condensate to escape.

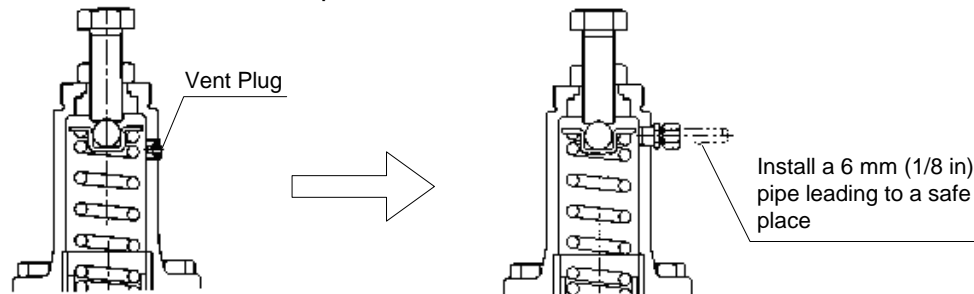

## Installing a Diffuser and Strainer

If the steam flow velocity in the pipe on the secondary side is expected to exceed 30 meters per second (100 ft/sec)\*, install a diffuser to increase the pipe size and reduce the flow in the pipe to below that level.

A strainer should be installed ahead of the product. The strainer should be 60-mesh or greater but not so fine that it causes constriction of the flow area and a subsequent pressure drop. The strainer should be installed horizontally and at 90 degrees to its normal orientation to the pipeline in order to prevent condensate accumulation in the screen body.

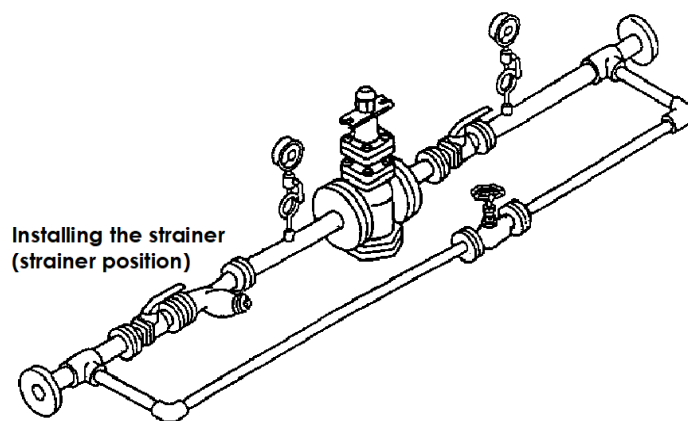

## Flow rate Calculation Formula

$$V = \frac{2.78 W \cdot V''}{a} = \frac{3.53 W \cdot V''}{d^2} \text{ (m/s)}$$

$$V = \frac{0.0509 W \cdot V}{d^2} \text{ (ft/s)}$$

W = average-flow·(kg/hr)(lb/hr)

V'' = specific-volume·(m<sup>3</sup>/kg)(ft<sup>3</sup>/lb)

a = inside-pipe-area·(cm<sup>2</sup>)(in<sup>2</sup>)

d = pipe-ID·(cm)(in)

## Configuration

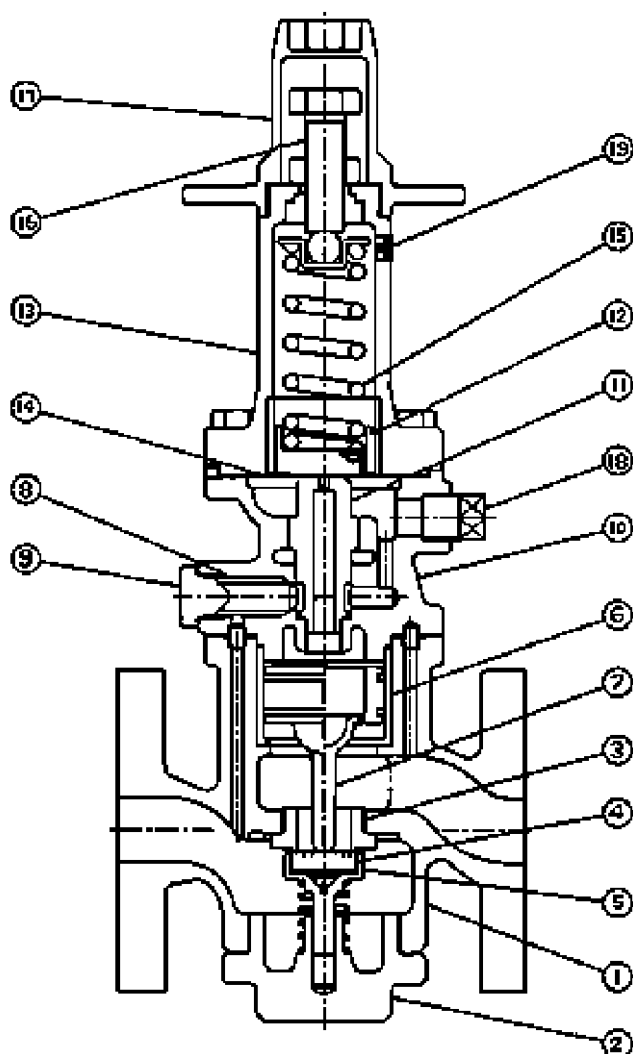

No.	Name
1	Main Body
2	Cover Plug (15 – 25 mm)
	Cover (32 – 50 mm)
3	Main Valve Seat
4	Main Valve
5	Main Valve Holder
6	Cylinder
7	Piston
8	Pilot Screen
9	Pilot Screen Holder
10	Pilot Body
11	Pilot Valve
12	Diaphragm Support
13	Spring Housing
14	Diaphragm
15	Coil Spring
16	Adjustment Screw
17	Spanner Cap
18	Plug (R $\frac{3}{8}$ )
19	Vent Plug (R $\frac{1}{8}$ )

NOTE: Sizes 15 – 25 mm ( $\frac{1}{2}$  – 1 in) shown.

Configuration for sizes 32 – 50 mm ( $1\frac{1}{4}$  – 2 in) differs slightly.

## Adjustment

The product must be properly adjusted for protection of the steam-using equipment against water hammer.

1. On newly installed piping or after the system has been shut down for a long period of time, use the bypass valve to blow out the pipes thoroughly. Be especially careful that no condensate and rust, etc. is left in the steam-using equipment.
2. Make sure that the bypass valve and the shut-off valves upstream and downstream of the product are completely closed.
3. Open the shut-off valve on the secondary side all the way and then open the shut-off valve on the primary side slightly.
4. After supplying steam to the product, check to make sure that the product operates properly and there is no leakage from the pipes, etc. Then closely open the shut-off valve on the primary side all the way.
5. When the set pressure must be readjusted, use the following procedure.
6. Open the shut-off valve on the secondary side all the way, then open the shut-off valve on the primary side slightly.
7. Remove the spanner cap and loosen the locknut by turning it counter-clockwise.

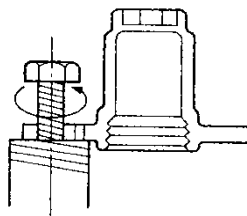

Loosen the locknut

8. While monitoring the primary pressure gauge, decrease the pressure by turning the adjustment screw counter-clockwise to loosen it, or increase the pressure by turning the adjustment screw clockwise to tighten it. Do this until the desired pressure is attained.

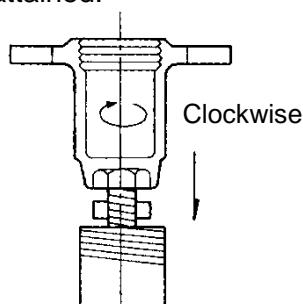

Tighten the Adjustment Screw  
Increase Pressure

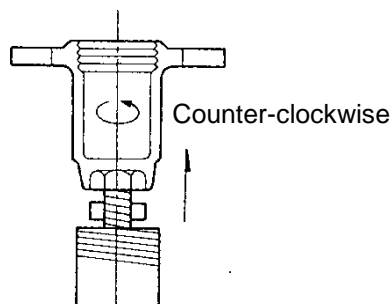

Loosen the Adjustment Screw  
Decrease Pressure

9. If the pressure is too high or low, turn the adjustment screw to adjust the pressure to a suitable setting. After the adjustment, retighten the locknut before opening the shut-off valve on the primary side all the way.
10. Replace the spanner cap.
11. To stop steam supply, close the shut-off valves upstream and downstream of the valve.



## Disassembly and Inspection

Disassembling and inspecting the valve once a year can help prevent unexpected failure. We recommend that you inspect the valve right after operating the system with newly installed piping or after the system has been out of service for a long period of time.

### Exploded Diagram

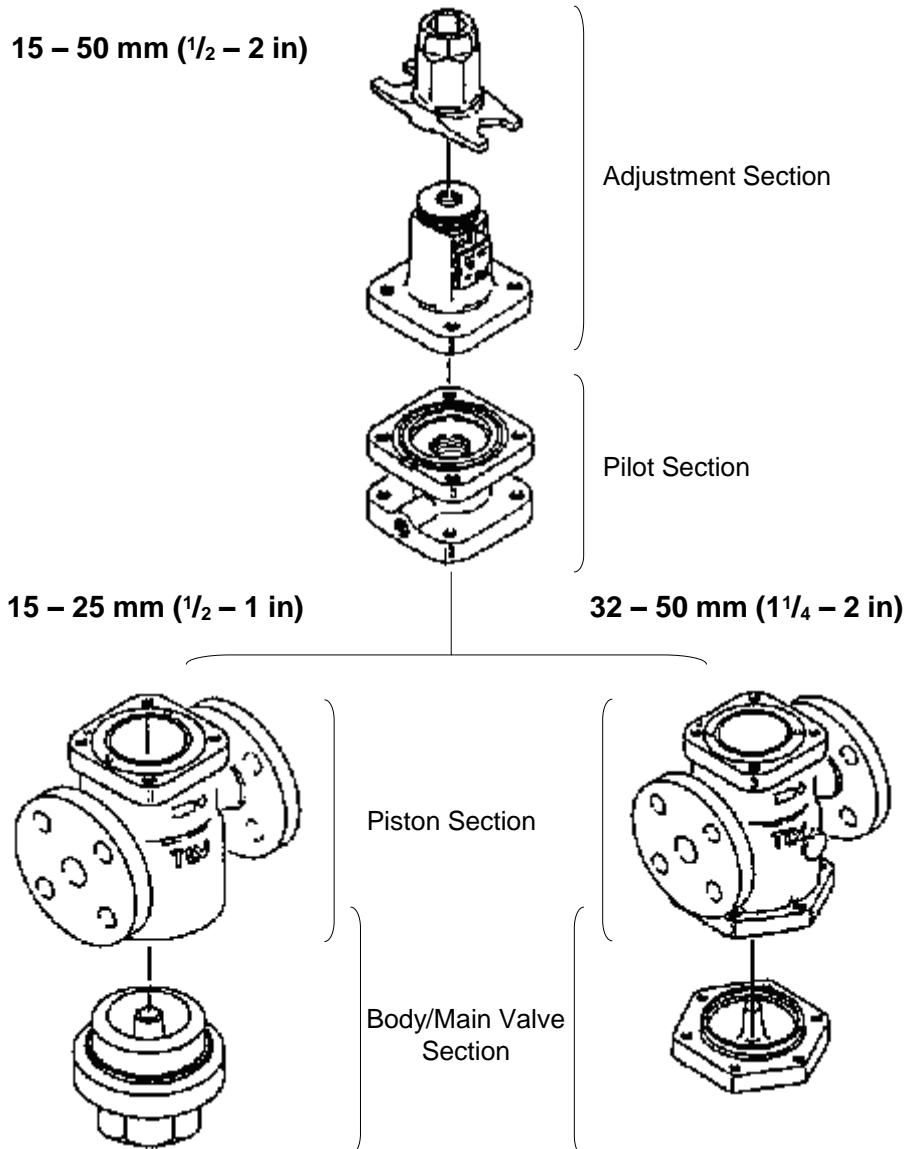

First release the pressure in the piping completely (on both primary and secondary sides). If the pressure cannot be eliminated, switch to bypass operation and completely close the shut-off valves upstream and downstream of the product. Then slightly loosen the hex bolt on the spring housing and the pilot screen holder or plug to relieve the residual steam pressure.

To disassemble the valve, remove the bolts and nuts on the inlet and outlet flanges and fasten the valve in a vise before starting the inspection.

## Disassembling the Adjustment Section

Check to make sure there are no damaged or missing screws.

Loosen the locknut by turning it counter-clockwise, then loosen the adjustment screw all the way and remove the hex bolt. Removing the spring housing will reveal the diaphragm support, coil spring and spring retainer.

15 – 50 mm ( $\frac{1}{2}$  – 2 in)

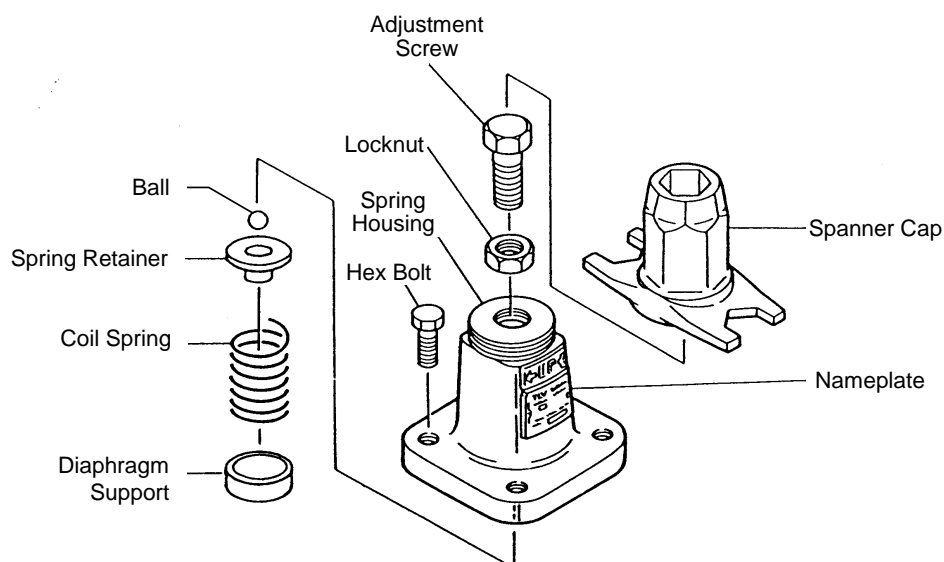

## Disassembling the Pilot Section

Check to make sure there are no scratches on the pilot valve seat or flaws in the gasket and that the pilot screen is not clogged. Also check to make sure the diaphragm is not warped, scratched or corroded. The diaphragm should be convex (open downward).

To remove the diaphragm, place the tip of a screw driver in the notch in the pilot body and lift up. Using a box wrench, loosen the pilot valve and remove it. Then remove the pilot screen holder and pilot screen.

15 – 50 mm ( $\frac{1}{2}$  – 2 in)

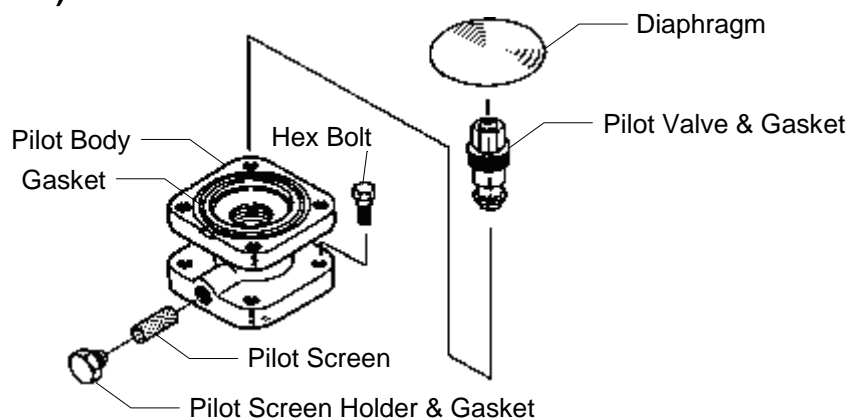

## Disassembling the Piston Section

Check the inside of the cylinder, the outside of the piston ring, the tiny holes in the piston and the gasket to make sure all are in good condition.

Loosen the hex (stud) bolt and then remove the pilot body. During this process, be careful not to lose the two connecting tubes. Take the piston and cylinder out of the body, then remove the piston ring and tension ring from the piston. Be careful not to apply excessive force when removing the piston and tension rings.

**15 - 50 mm ( $\frac{1}{2}$  - 2 in)**

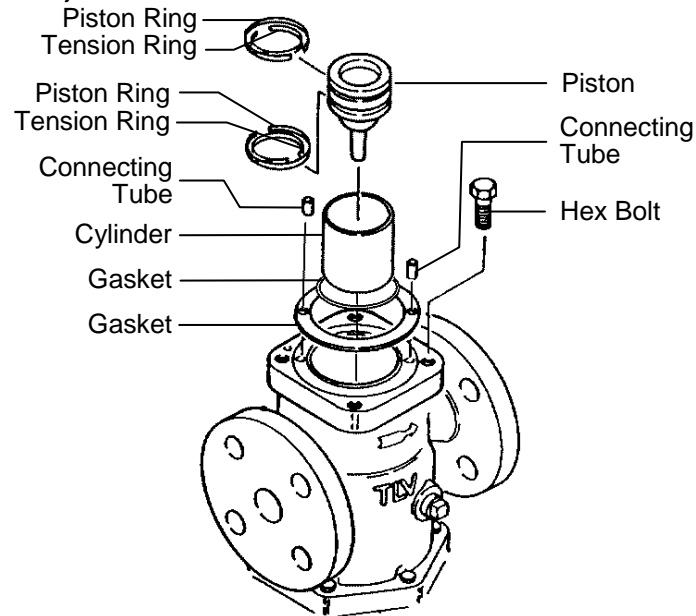

## Disassembling the Main Body and Main Valve Section

Check the seating and sliding surfaces of the main valve and main valve seat to make sure that they are not damaged. When starting up the equipment after it has been idle for a long period of time, always blow out the piston section of the body through the cover plug when steam is supplied.

Turn the product upside down to make it easier to disassemble the main body and main valve section. For 15, 20 and 25 mm ( $\frac{1}{2}$ ,  $\frac{3}{4}$  and 1 in.) valves, turn the cover counter-clockwise and remove it. For 32, 40 and 50 mm ( $1\frac{1}{4}$ ,  $1\frac{1}{2}$  and 2 in) valves, loosen the cover bolts and remove the cover. This will enable the main valve and main valve spring to be removed. Use a box wrench to loosen the main valve seat and remove it from the body.

### 15 – 25 mm ( $\frac{1}{2}$ – 1 in)

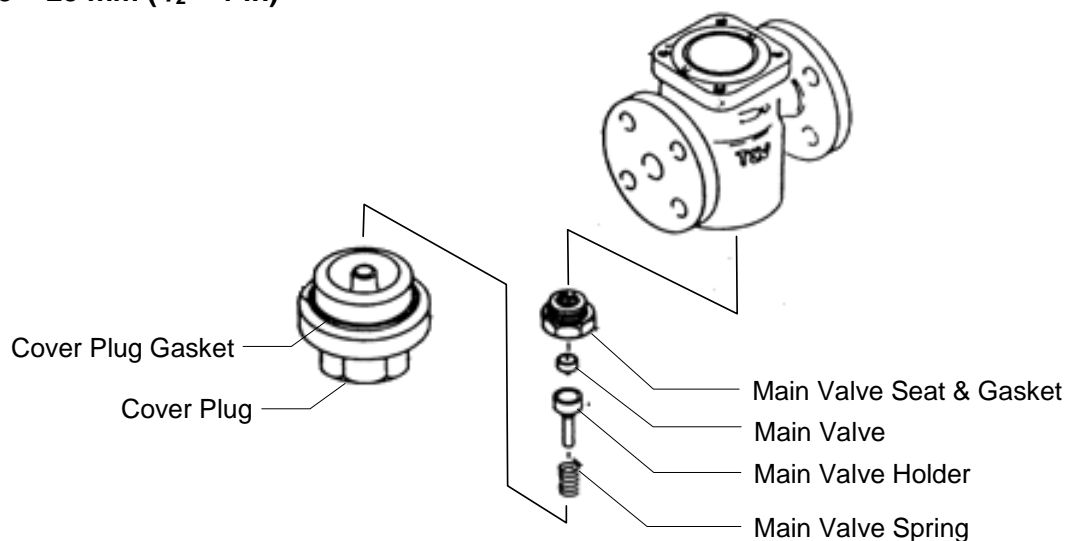

### 32 – 50 mm ( $1\frac{1}{4}$ – 2 in)

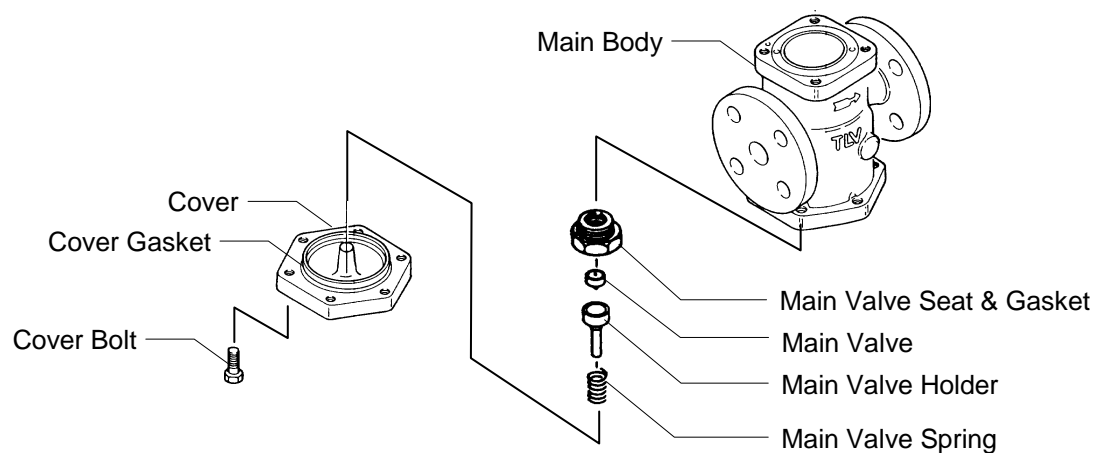

## Cleaning

Check each section and, if there are no problems, clean and reassemble the parts. The following parts will require cleaning before reassembly:

Piston and Tension Rings		
Diaphragm Support		
Inside of Spring Housing (parts that come into contact with the diaphragm retainer)		
Cylinder	Pilot Screen	Main Valve seat
Pilot Valve	Diaphragm	Main Valve
Adjustment Screw	Piston	

Although these parts may be simply rinsed in water, it would be more effective to use a mild detergent. Carefully wipe components dry after cleaning; especially, the inside of the spring housing, the diaphragm retainer, adjustment screw and diaphragm.

## Assembly

Assemble by following the disassembly procedure in reverse. Use the following guidelines:

1. PTFE gaskets may be used if they are not damaged, crushed or warped.
2. Apply anti-seize agent to screws and bolts, spring retainer ball and adjustment screw. On the threads of main valve seats, pilot valves and pilot screen holder screws, use the anti-seize agent sparingly to make sure it does not come into contact with other parts.
3. Fasten the bolts one at a time in a diagonally alternate pattern to provide uniform seating.
4. During assembly, check to make sure the piston moves smoothly.
5. Assemble the piston and tension rings as follows:
  - Fit the piston ring to the outside of the tension ring.
  - Make sure the ring gaps are opposite one another.
6. The following table shows the screw tightening torque and tool width across flats:

Parts Name	Size		Distance Across Flats		*Torque	
	mm	(in)	mm	(in)	N·m	(ft·lb)
Bolt for Spring Housing	–		17	( <sup>11</sup> / <sub>16</sub> )	40	(29)
Pilot Valve	–		19	( <sup>3</sup> / <sub>4</sub> )	70	(51)
Pilot Screen Holder	–		24	( <sup>15</sup> / <sub>16</sub> )	40	(29)
Bolt for Pilot Body	15–40	( <sup>1</sup> / <sub>2</sub> –1 <sup>1</sup> / <sub>2</sub> )	17	( <sup>11</sup> / <sub>16</sub> )	60	(43)
	50	(2)	19	( <sup>3</sup> / <sub>4</sub> )	70	(51)
Main Valve Seat	15–20	( <sup>1</sup> / <sub>2</sub> – <sup>3</sup> / <sub>4</sub> )	36	( <sup>17</sup> / <sub>16</sub> )	100	(72)
	25	(1)	41	( <sup>15</sup> / <sub>8</sub> )	125	(90)
	32–40	( <sup>1</sup> / <sub>4</sub> –1 <sup>1</sup> / <sub>2</sub> )	60	( <sup>23</sup> / <sub>8</sub> )	250	(180)
	50	(2)	70	( <sup>23</sup> / <sub>4</sub> )	300	(216)
Cover Plug	15–20	( <sup>1</sup> / <sub>2</sub> – <sup>3</sup> / <sub>4</sub> )	41	( <sup>15</sup> / <sub>8</sub> )	250	(180)
	25	(1)	46	( <sup>13</sup> / <sub>16</sub> )	350	(253)
Cover Bolt	32–40	( <sup>1</sup> / <sub>4</sub> –1 <sup>1</sup> / <sub>2</sub> )	17	( <sup>11</sup> / <sub>16</sub> )	60	(43)
	50	(2)	19	( <sup>3</sup> / <sub>4</sub> )	70	(51)

(1 N·m ≈ 10kg·cm)

\*Tightening screws and bolts to greater than the recommended torque may damage the body or parts.

## Regular Inspection and Maintenance

When using the product over an extended period of time, inspections and maintenance should be done regularly as described in the table below. For newly installed piping, even if the pipes are blown out during installation, the strainer in the product and the strainer in front of the product will need to be cleaned frequently, as there will be welding chips and sealant residue from the pipe threads and gaskets.

Part	Guidelines for Inspection and Maintenance
Pilot Screen	Disassemble and clean annually. If the pilot screen is substantially blocked, install a strainer (60-mesh) at the product inlet.
Pilot Valve Main Valve Seat Diaphragm	Replace after approximately 15,000 hours. If there is obstruction from rust and scale, these parts may wear out more quickly.
Piston Rings and Tension Rings	Replace after approximately 8,000 hours. If scale buildup is severe, these parts may wear out more quickly.
Piston	Replace after approximately 30,000 hours.

## Troubleshooting

This product is shipped after stringent quality checks and inspections and should perform its intended function for a long period of time without failure. However, in the event that trouble should occur, check the flow diagram on the following pages and take the appropriate measure. Problems can be classified into three major categories:

1. The primary pressure rises.
2. Abnormal drop in primary pressure. [Hunting (primary pressure fluctuates)].
3. Primary pressure adjustment is not possible or primary pressure rises. [Hunting occurs (primary pressure fluctuates)].

Problems are particularly likely to occur when the valve is used outside the range of specifications; when the flow rate used for valve selection is insufficient, or when valve closure is hindered by trapped rust or scale. In order to ensure proper performance, review the Piping (page 4) and Adjustment (page 7) procedures given in this manual.

**Problems and Solutions**

(1) The primary pressure rises

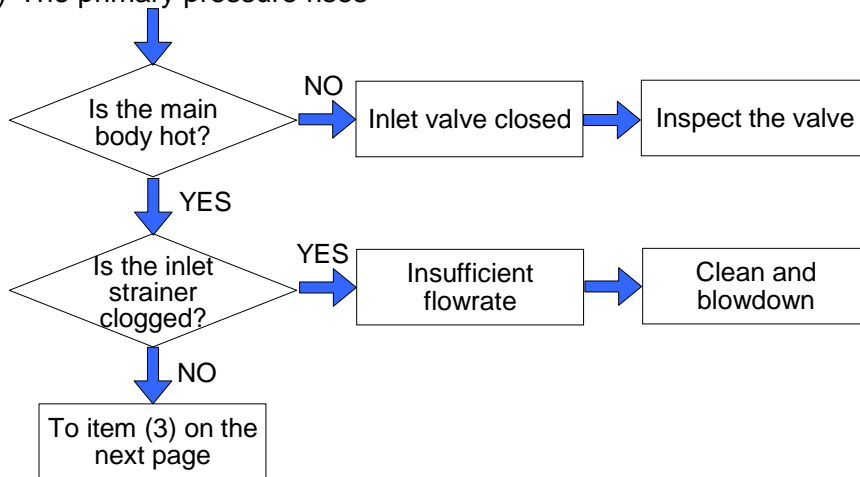

(2) Abnormal drop in primary pressure

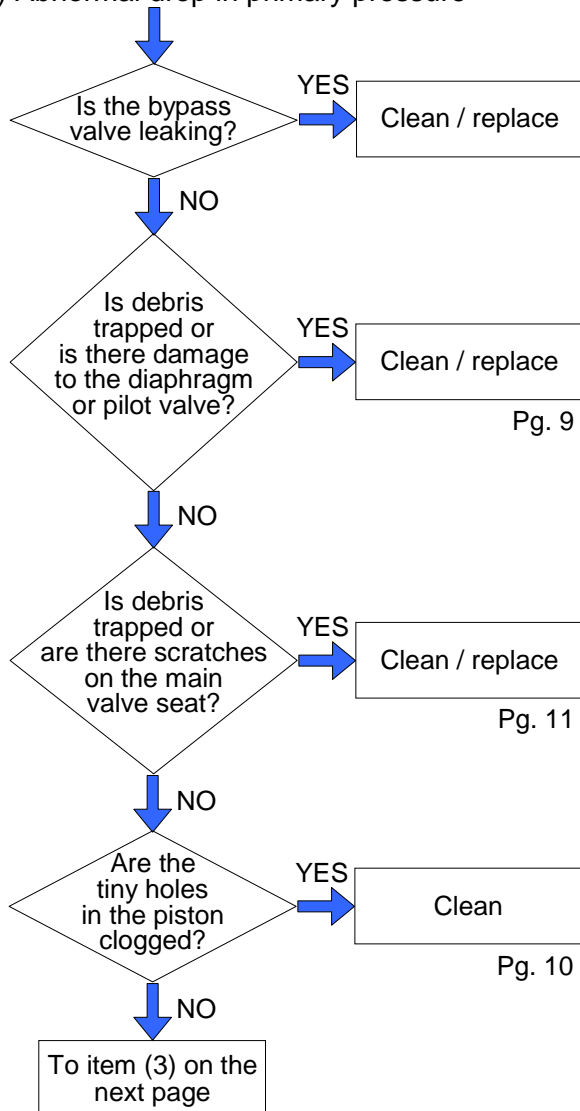

(3) Primary pressure adjustment is not possible or primary pressure rises.  
 [Hunting occurs (primary pressure fluctuates)].

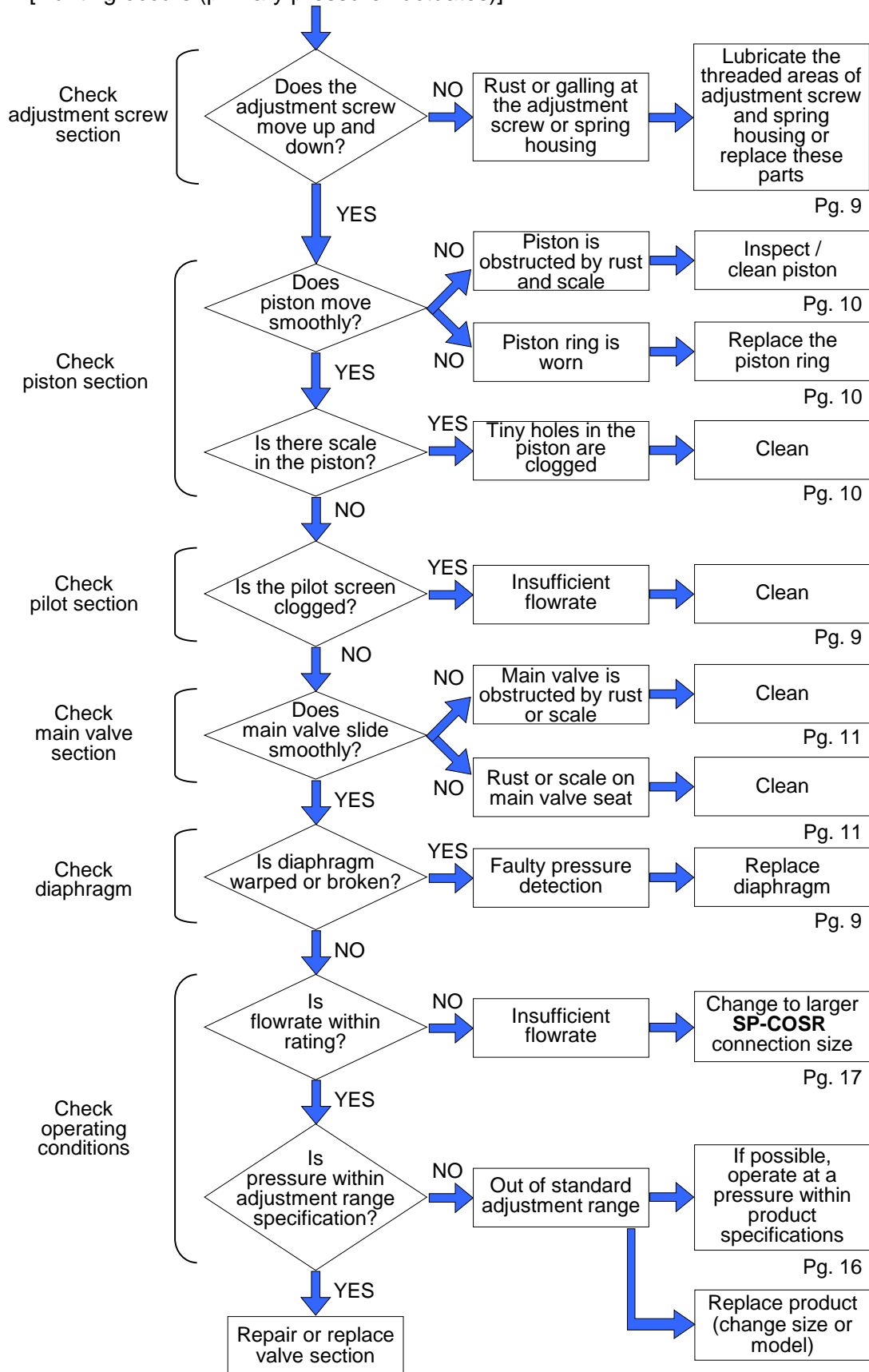



## Specifications

### Specifications for SP-COSR-16 Primary Pressure Control Valve

Applicable Fluid		Steam
Pressure Setting Range: MPaG (psig)		0.1 to 1.0 (15 to 150)
Nominal Diameter: mm (in.)		15, 20, 25, 32, 40, 50 (1/2, 3/4, 1, 1 1/4, 1 1/2, 2)
Max. Operating Pressure: MPaG (psig)		1.6 (230)
Max. Operating Temperature: °C (°F)		220 (428)
Material	Main Body	Cast Iron or Ductile Cast Iron
	Main Valve and Main Valve Seat	Stainless Steel
	Pilot Valve Seat	Stainless Steel
	Diaphragm	Stainless Steel
	Connection	Flange: FF/RF Screwed: Rc(PT), NPT, BSP

### Flow rate Characteristics Graph

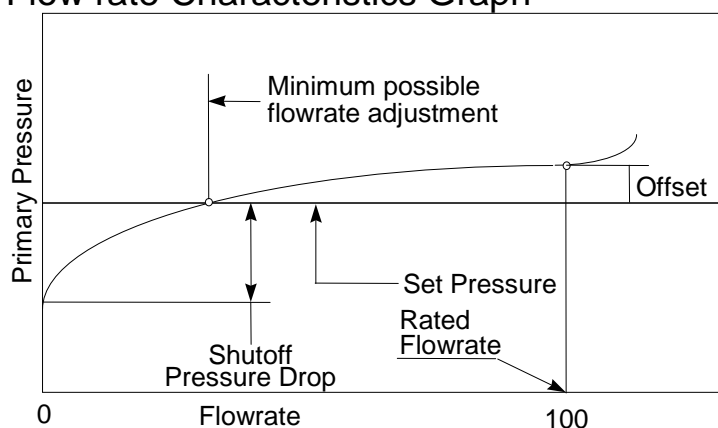

Performance	
Offset	Max. 0.03 MPa (5 psi)
Shutoff Pressure	Max. 0.02 MPa (3 psi)
Minimum Flowrate Adjustment	5% of rated flow
Main Valve Seat Leakage	Max. 0.05% of rated flow

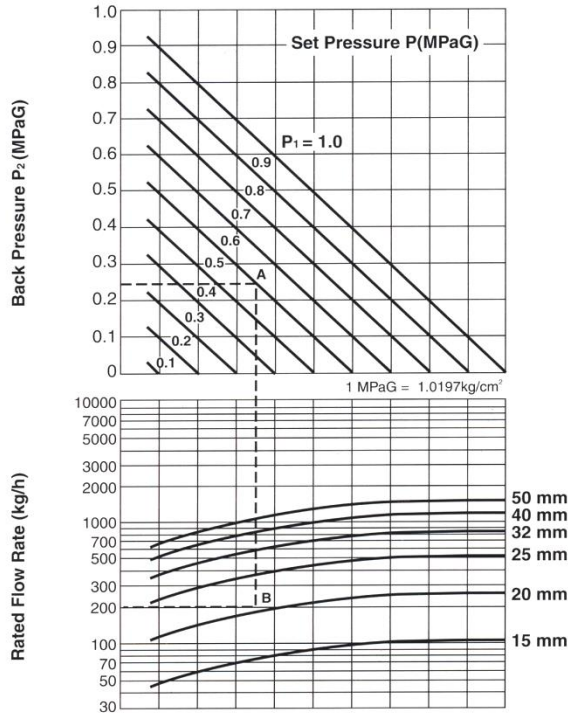

In the graph at left, find the nominal diameter for that meets the following conditions:

Set Pressure: (P<sub>1</sub>) 0.6 MPaG  
 Secondary Pressure: (P<sub>2</sub>) 0.25 MPaG  
 Flow rate: 200 kg/H

First find the intersection (point A) of the set pressure (P<sub>1</sub>: 0.6 MPaG) and the secondary pressure (P<sub>2</sub>: 0.25 MPaG).

Draw a vertical line from point A and find the intersection (point B) with 200 kg/H.

Point B is between nominal dia. 20 mm and 25 mm, so choose the larger size. Accordingly, the 25 mm size should be selected.

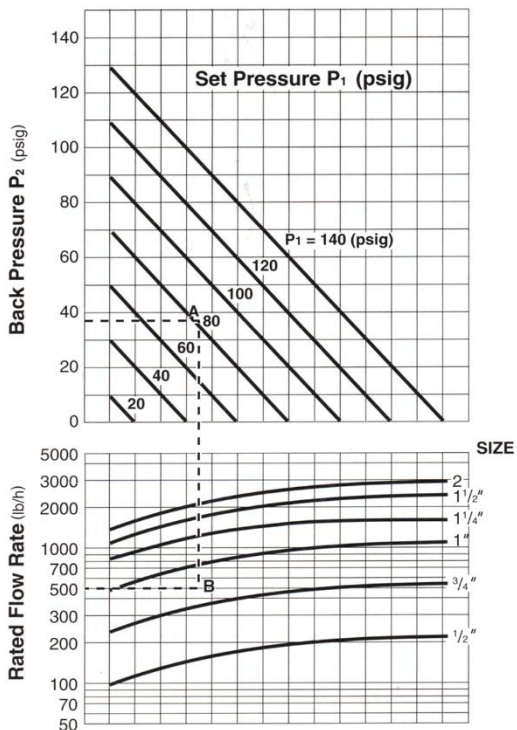

In the graph at left, find the nominal diameter that meets the following conditions:

Set Pressure: (P<sub>1</sub>) 80 psig  
 Secondary Pressure: (P<sub>2</sub>) 35 psig  
 Flow rate: 500 lb/H

First find the intersection (point A) of the set pressure (P<sub>1</sub>: 80 psig) and the secondary pressure (P<sub>2</sub>: 35 psig).

Draw a vertical line from point A and find the intersection (point B) with 500 lb/H.

Point B is between nominal dia. 3/4 in. and 1 in., so choose the larger size. Accordingly, the 1 in. size should be selected.

## TLV EXPRESS LIMITED WARRANTY

Subject to the limitations set forth below, TLV CO., LTD., a Japanese corporation (“**TLV**”), warrants that products which are sold by it, TLV International Inc. (“**TII**”) or one of its group companies excluding TLV Corporation (a corporation of the United States of America), (hereinafter the “**Products**”) are designed and manufactured by TLV, conform to the specifications published by TLV for the corresponding part numbers (the “**Specifications**”) and are free from defective workmanship and materials. The party from whom the Products were purchased shall be known hereinafter as the “**Seller**”. With regard to products or components manufactured by unrelated third parties (the “**Components**”), TLV provides no warranty other than the warranty from the third party manufacturer(s), if any.

### Exceptions to Warranty

This warranty does not cover defects or failures caused by:

1. improper shipping, installation, use, handling, etc., by persons other than TLV, TII or TLV group company personnel, or service representatives authorized by TLV; or
2. dirt, scale or rust, etc.; or
3. improper disassembly and reassembly, or inadequate inspection and maintenance by persons other than TLV or TLV group company personnel, or service representatives authorized by TLV; or
4. disasters or forces of nature or Acts of God; or
5. abuse, abnormal use, accidents or any other cause beyond the control of TLV, TII or TLV group companies; or
6. improper storage, maintenance or repair; or
7. operation of the Products not in accordance with instructions issued with the Products or with accepted industry practices; or
8. use for a purpose or in a manner for which the Products were not intended; or
9. use of the Products in a manner inconsistent with the Specifications; or
10. use of the Products with Hazardous Fluids (fluids other than steam, air, water, nitrogen, carbon dioxide and inert gases (helium, neon, argon, krypton, xenon and radon)); or
11. failure to follow the instructions contained in the TLV Instruction Manual for the Product.

### Duration of Warranty

This warranty is effective for a period of one (1) year after delivery of Products to the first end user. Notwithstanding the foregoing, asserting a claim under this warranty must be brought within three (3) years after the date of delivery to the initial buyer if not sold initially to the first end user.

ANY IMPLIED WARRANTIES NOT NEGATED HEREBY WHICH MAY ARISE BY OPERATION OF LAW, INCLUDING THE IMPLIED WARRANTIES OF MERCHANTABILITY AND FITNESS FOR A PARTICULAR PURPOSE AND ANY EXPRESS WARRANTIES NOT NEGATED HEREBY, ARE GIVEN SOLELY TO THE INITIAL BUYER AND ARE LIMITED IN DURATION TO ONE (1) YEAR FROM THE DATE OF SHIPMENT BY THE SELLER.

### Exclusive Remedy

THE EXCLUSIVE REMEDY UNDER THIS WARRANTY, UNDER ANY EXPRESS WARRANTY OR UNDER ANY IMPLIED WARRANTIES NOT NEGATED HEREBY (INCLUDING THE IMPLIED WARRANTIES OF MERCHANTABILITY AND FITNESS FOR A PARTICULAR PURPOSE), IS **REPLACEMENT**; PROVIDED: (a) THE CLAIMED DEFECT IS

REPORTED TO THE SELLER IN WRITING WITHIN THE WARRANTY PERIOD, INCLUDING A DETAILED WRITTEN DESCRIPTION OF THE CLAIMED DEFECT AND HOW AND WHEN THE CLAIMED DEFECTIVE PRODUCT WAS USED; AND (b) THE CLAIMED DEFECTIVE PRODUCT AND A COPY OF THE PURCHASE INVOICE IS RETURNED TO THE SELLER, FREIGHT AND TRANSPORTATION COSTS PREPAID, UNDER A RETURN MATERIAL AUTHORIZATION AND TRACKING NUMBER ISSUED BY THE SELLER. ALL LABOR COSTS, SHIPPING COSTS, AND TRANSPORTATION COSTS ASSOCIATED WITH THE RETURN OR REPLACEMENT OF THE CLAIMED DEFECTIVE PRODUCT ARE SOLELY THE RESPONSIBILITY OF BUYER OR THE FIRST END USER. THE SELLER RESERVES THE RIGHT TO INSPECT ON THE FIRST END USER'S SITE ANY PRODUCTS CLAIMED TO BE DEFECTIVE BEFORE ISSUING A RETURN MATERIAL AUTHORIZATION. SHOULD SUCH INSPECTION REVEAL, IN THE SELLER'S REASONABLE DISCRETION, THAT THE CLAIMED DEFECT IS NOT COVERED BY THIS WARRANTY, THE PARTY ASSERTING THIS WARRANTY SHALL PAY THE SELLER FOR THE TIME AND EXPENSES RELATED TO SUCH ON-SITE INSPECTION.

#### **Exclusion of Consequential and Incidental Damages**

IT IS SPECIFICALLY ACKNOWLEDGED THAT THIS WARRANTY, ANY OTHER EXPRESS WARRANTY NOT NEGATED HEREBY, AND ANY IMPLIED WARRANTY NOT NEGATED HEREBY, INCLUDING THE IMPLIED WARRANTIES OF MERCHANTABILITY AND FITNESS FOR A PARTICULAR PURPOSE, DO NOT COVER, AND NEITHER TLV, TII NOR ITS TLV GROUP COMPANIES WILL IN ANY EVENT BE LIABLE FOR, INCIDENTAL OR CONSEQUENTIAL DAMAGES, INCLUDING, BUT NOT LIMITED TO LOST PROFITS, THE COST OF DISASSEMBLY AND SHIPMENT OF THE DEFECTIVE PRODUCT, INJURY TO OTHER PROPERTY, DAMAGE TO BUYER'S OR THE FIRST END USER'S PRODUCT, DAMAGE TO BUYER'S OR THE FIRST END USER'S PROCESSES, LOSS OF USE, OR OTHER COMMERCIAL LOSSES. WHERE, DUE TO OPERATION OF LAW, CONSEQUENTIAL AND INCIDENTAL DAMAGES UNDER THIS WARRANTY, UNDER ANY OTHER EXPRESS WARRANTY NOT NEGATED HEREBY OR UNDER ANY IMPLIED WARRANTY NOT NEGATED HEREBY (INCLUDING THE IMPLIED WARRANTIES OF MERCHANTABILITY AND FITNESS FOR A PARTICULAR PURPOSE) CANNOT BE EXCLUDED, SUCH DAMAGES ARE EXPRESSLY LIMITED IN AMOUNT TO THE PURCHASE PRICE OF THE DEFECTIVE PRODUCT. THIS EXCLUSION OF CONSEQUENTIAL AND INCIDENTAL DAMAGES, AND THE PROVISION OF THIS WARRANTY LIMITING REMEDIES HEREUNDER TO REPLACEMENT, ARE INDEPENDENT PROVISIONS, AND ANY DETERMINATION THAT THE LIMITATION OF REMEDIES FAILS OF ITS ESSENTIAL PURPOSE OR ANY OTHER DETERMINATION THAT EITHER OF THE ABOVE REMEDIES IS UNENFORCEABLE, SHALL NOT BE CONSTRUED TO MAKE THE OTHER PROVISIONS UNENFORCEABLE.

#### **Exclusion of Other Warranties**

THIS WARRANTY IS IN LIEU OF ALL OTHER WARRANTIES, EXPRESS OR IMPLIED, AND ALL OTHER WARRANTIES, INCLUDING BUT NOT LIMITED TO THE IMPLIED WARRANTIES OF MERCHANTABILITY AND FITNESS FOR A PARTICULAR PURPOSE, ARE EXPRESSLY DISCLAIMED.

#### **Severability**

Any provision of this warranty which is invalid, prohibited or unenforceable in any jurisdiction shall, as to such jurisdiction, be ineffective to the extent of such invalidity, prohibition or unenforceability without invalidating the remaining provisions hereof, and any such invalidity, prohibition or unenforceability in any such jurisdiction shall not invalidate or render unenforceable such provision in any other jurisdiction.

## Service

For Service or Technical Assistance: Contact your TLV representative or your regional TLV office.

### In Europe:

#### **TLV EURO ENGINEERING GmbH**

Daimler-Benz-Straße 16-18, 74915 Waibstadt, **Germany**

Tel: [49]-(0)7263-9150-0  
Fax: [49]-(0)7263-9150-50

#### **TLV EURO ENGINEERING UK LTD.**

Units 7 & 8, Furlong Business Park, Bishops Cleeve, Gloucestershire GL52 8TW, **U.K.**

Tel: [44]-(0)1242-227223  
Fax: [44]-(0)1242-223077

#### **TLV EURO ENGINEERING FRANCE SARL**

Parc d'Ariane 2, bât. C, 290 rue Ferdinand Perrier, 69800 Saint Priest, **France**

Tel: [33]-(0)4-72482222  
Fax: [33]-(0)4-72482220

### In North America:

#### **TLV CORPORATION**

13901 South Lakes Drive, Charlotte, NC 28273-6790, **U.S.A.**

Tel: [1]-704-597-9070  
Fax: [1]-704-583-1610

### In Mexico and Latin America:

#### **TLV ENGINEERING S. A. DE C.V.**

Av. Jesús del Monte 39-B-1001, Col. Hda. de las Palmas, Huixquilucan, Edo. de México, 52763, **Mexico**

Tel: [52]-55-5359-7949  
Fax: [52]-55-5359-7585

### In Oceania:

#### **TLV PTY LIMITED**

Unit 8, 137-145 Rooks Road, Nunawading, Victoria 3131, **Australia**

Tel: [61]-(0)3-9873 5610  
Fax: [61]-(0)3-9873 5010

### In East Asia:

#### **TLV PTE LTD**

36 Kaki Bukit Place, #02-01/02, **Singapore** 416214

Tel: [65]-6747 4600  
Fax: [65]-6742 0345

#### **TLV SHANGHAI CO., LTD.**

Room 5406, No. 103 Cao Bao Road, Shanghai, **China** 200233

Tel: [86]-(0)21-6482-8622  
Fax: [86]-(0)21-6482-8623

#### **TLV ENGINEERING SDN. BHD.**

No.16, Jalan MJ14, Taman Industri Meranti Jaya, 47120 Puchong, Selangor, **Malaysia**

Tel: [60]-3-8065-2928  
Fax: [60]-3-8065-2923

#### **TLV PRIVATE LIMITED**

252/94 (K-L) 17th Floor, Muang Thai-Phatra Complex Tower B, Rachadaphisek Road, Huaykwang, Bangkok 10310, **Thailand**

Tel: [66]-2-693-3799  
Fax: [66]-2-693-3979

#### **TLV INC.**

#302-1 Bundang Technopark B, 723 Pangyo-ro, Bundang, Seongnam, Gyeonggi, 13511, **Korea**

Tel: [82]-(0)31-726-2105  
Fax: [82]-(0)31-726-2195

### In the Middle East:

#### **TLV ENGINEERING FZCO**

Building 2W, No. M002, PO Box 371684, Dubai Airport Free Zone, Dubai, **UAE**

Email: sales-me@tlv.co.jp

### In Other Countries:

#### **TLV INTERNATIONAL, INC.**

881 Nagasuna, Noguchi, Kakogawa, Hyogo 675-8511, **Japan**

Tel: [81]-(0)79-427-1818  
Fax: [81]-(0)79-425-1167

### Manufacturer:

#### **TLV CO., LTD.**

881 Nagasuna, Noguchi, Kakogawa, Hyogo 675-8511, **Japan**

Tel: [81]-(0)79-422-1122  
Fax: [81]-(79-422-0112