



Manufacturer

TLV CO., LTD.

Kakogawa, Japan

is approved by LRQA Ltd. to ISO 9001/14001



Instruction Manual

Free Float Air Trap JAH7.2R / JAH7.5R / JAH8R

Manufacturer

TLV CO., LTD.

881 Nagasuna, Noguchi, Kakogawa, Hyogo, 675-8511, Japan

Tel: [81]-(0)79-422-1122 Fax: [81]-(0)79-422-0112

Copyright © 2021 by TLV CO., LTD. All rights reserved

TLV CORPORATION

Contents

Introduction	1
Safety Considerations	2
Checking the Piping	4
Operation	5
Specifications	6
Configuration	7
Installation	9
The Need for a Pressure-balancing Line	10
Maintenance	11
Disassembly/Reassembly	12
Instructions for Plug/Holder Disassembly and Reassembly ...	17
Troubleshooting	18
Option	19
TLV EXPRESS LIMITED WARRANTYエラー! ブックマークが定義されていません。	

Introduction

Thank you for purchasing the TLV free float air trap.

This product has been thoroughly inspected before being shipped from the factory. When the product is delivered, before doing anything else, check the specifications and external appearance to make sure nothing is out of the ordinary. Also be sure to read this manual carefully before use and follow the instructions to be sure of using the product properly.





If detailed instructions for special order specifications or options not contained in this manual are required, please contact TLV for full details.



This instruction manual is intended for use with the model(s) listed on the front cover. It is necessary not only for installation but for subsequent maintenance, disassembly/reassembly and troubleshooting. Please keep it in a safe place for future reference.

Safety Considerations

- Read this section carefully before use and be sure to follow the instructions.
- Installation, inspection, maintenance, repairs, disassembly, adjustment and valve opening/closing should be carried out only by trained maintenance personnel.
- The precautions listed in this manual are designed to ensure safety and prevent equipment damage and personal injury. For situations that may occur as a result of erroneous handling, three different types of cautionary items are used to indicate the degree of urgency and the scale of potential damage and danger: DANGER, WARNING and CAUTION.
- The three types of cautionary items above are very important for safety: be sure to observe all of them as they relate to installation, use, maintenance, and repair. Furthermore, TLV accepts no responsibility for any accidents or damage occurring as a result of failure to observe these precautions.

Symbols

	Indicates a DANGER, WARNING or CAUTION item.
	Indicates an urgent situation which poses a threat of death or serious injury
	Indicates that there is a potential threat of death or serious injury
	Indicates that there is a possibility of injury or equipment/product damage

	NEVER apply direct heat to the float. The float may explode due to increased internal pressure, causing accidents leading to serious injury or damage to property and equipment.
	Install properly and DO NOT use this product outside the recommended operating pressure, temperature and other specification ranges. Improper use may result in such hazards as damage to the product or malfunctions that may lead to serious accidents. Local regulations may restrict the use of this product to below the conditions quoted. DO NOT use this product in excess of the maximum operating pressure differential. Such use could make discharge impossible (blocked). Use hoisting equipment for heavy objects (weighing approximately 20 kg (44 lb) or more). Failure to do so may result in back strain or other injury if the object should fall. Use the eye bolts for removing the cover only; DO NOT use the eye bolts for hoisting the product. Eye bolts may break under strain, possibly resulting in serious injury.

Continued on the next page

 CAUTION	<p>Take measures to prevent people from coming into direct contact with product outlets. Failure to do so may result in burns or other injury from the discharge of fluids.</p>
	<p>When disassembling or removing the product, wait until the internal pressure equals atmospheric pressure and the surface of the product has cooled to room temperature. Disassembling or removing the product when it is hot or under pressure may lead to discharge of fluids, causing burns, other injuries or damage.</p>
	<p>Be sure to use only the recommended components when repairing the product, and NEVER attempt to modify the product in any way. Failure to observe these precautions may result in damage to the product and burns or other injury due to malfunction or the discharge of fluids.</p>
	<p>Use only under conditions in which no freeze-up will occur. Freezing may damage the product, leading to fluid discharge, which may cause burns or other injury.</p>
	<p>Use only under conditions in which no water hammer will occur. The impact of water hammer may damage the product, leading to fluid discharge, which may cause burns or other injury.</p>

Checking the Piping



Use only under conditions in which no water hammer will occur. The impact of water hammer may damage the product, leading to fluid discharge, which may cause burns or other injury.

Check to make sure that the pipes to be connected to the trap have been installed properly.

1. Is the pipe diameter suitable?
2. Is the piping where the trap is to be installed horizontal?
3. Has sufficient space been secured for maintenance?
4. Have isolation valves been installed at the inlet and outlet? If the outlet is subject to back pressure, has a check valve (TLV-CK) been installed?
5. Is the inlet pipe as short as possible, with as few bends as possible, and installed so the condensate will flow naturally down into the trap?
6. Has the piping work been done correctly, as shown in the figures below?

Selected examples are from piping for main lines

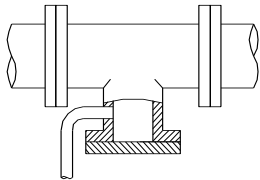
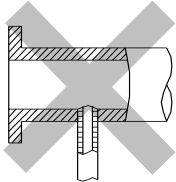
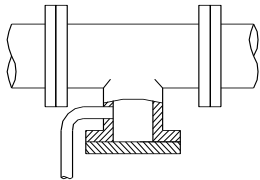
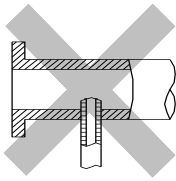
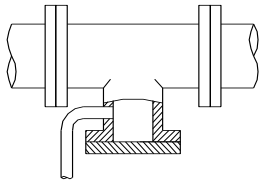
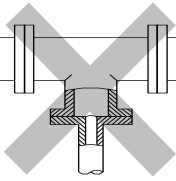
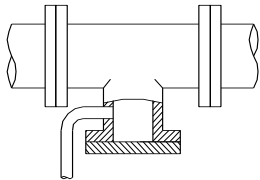
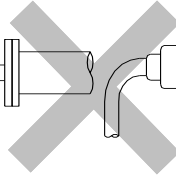
Requirement	Correct	Incorrect
Install catchpot with the proper diameter.		 Diameter is too small.
Make sure the flow of condensate is not obstructed.		 Diameter is too small and inlet protrudes into pipe interior.
To prevent rust and scale from flowing into the trap, the inlet pipe should be connected 25 – 50 mm (1 – 2 in) above the base of the T-pipe.		 Rust and scale flow into the trap with the condensate.
When installing on the blind end, make sure the flow of condensate is not obstructed.		 Condensate collects in the pipe.

Operation

Principles of condensate discharge:

1. Startup

At startup, a small amount of condensate will have accumulated in the body. The float and the valve seat will form a water-seal.

Note: When there is no condensate in the trap body, it will be necessary to prime the trap with a small amount of water through the pressure-balancing port or line to ensure a seal (after initial installation and after disassembly or maintenance)

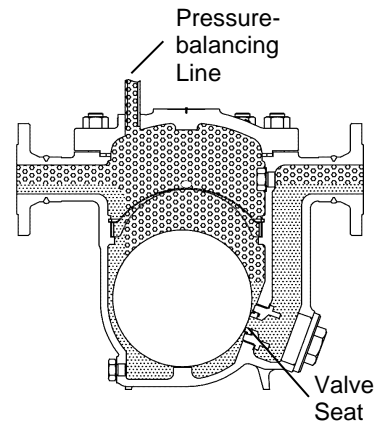

2. Condensate Discharge

As air is supplied, condensate flow begins. The rising condensate level causes the float to rise due to buoyancy, opening the valve seat and allowing condensate to be discharged.

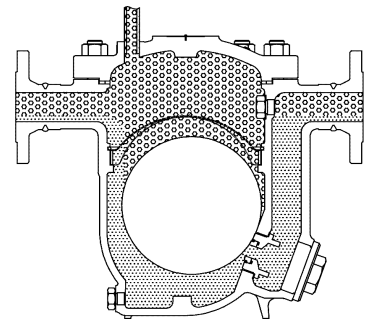

3. Discharge of Large Quantities of Condensate

Increases in the condensate inflow rate cause the condensate level in the trap to rise. The float consequently rises and enlarges the opening of the valve seat, allowing more condensate to be discharged. In this manner, continuous condensate discharge occurs while the opening size of the valve seat varies depending on the condensate flow rate.

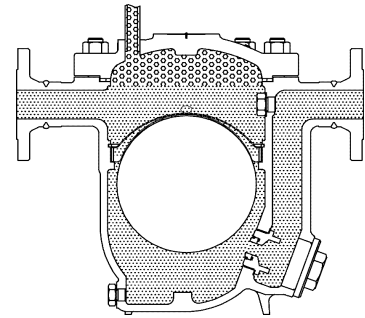

4. Closed Position

When the condensate flow rate decreases, the float falls, closing off the valve seat opening. A water seal is maintained at all times over the valve seat to prevent air loss.

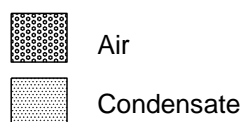
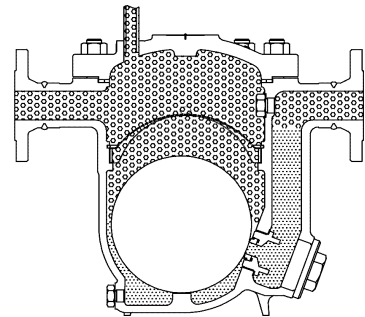

Specifications



Install properly and **DO NOT** use this product outside the recommended operating pressure, temperature and other specification ranges. Improper use may result in such hazards as damage to the product or malfunctions which may lead to serious accidents. Local regulations may restrict the use of this product to below the conditions quoted.



DO NOT use this product in excess of the maximum operating pressure differential; such use could make discharge impossible (blocked).



Use only under conditions in which no freeze-up will occur. Freezing may damage the product, leading to fluid discharge, which may cause burns or other injury.

Refer to the product nameplate for detailed specifications.

JAH7.2R

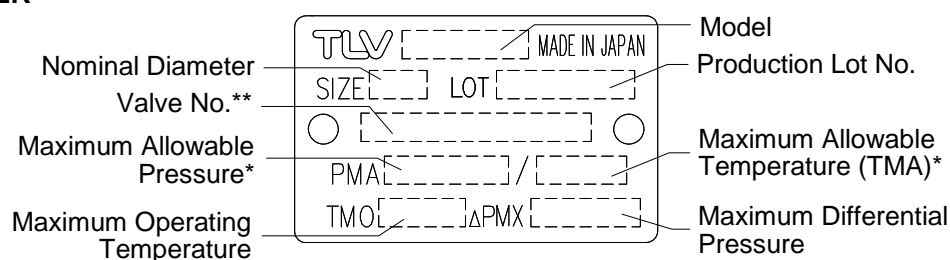

JAH7.5R / JAH8R

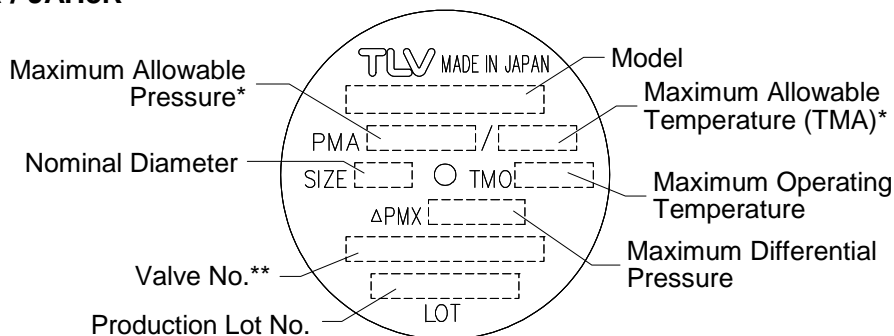

* Maximum allowable pressure (PMA) and maximum allowable temperature (TMA) are PRESSURE SHELL DESIGN CONDITIONS, **NOT** OPERATING CONDITIONS.

** Valve No. is displayed for products with options. This item is omitted from the nameplate when there are no options.

Minimum Required Condensate Load

Tight sealing can be secured by maintaining the minimum required condensate load, as air leaks may result if the inflowing condensate load falls below it.

Model		JAH7.2R	JAH7.5R	JAH8R	
				Orifice No.5 or below	Above Orifice No.5
Minimum Required Condensate Load	kg/h	10	10	20	15
	lb/h	22	22	44	33

NOTE: Orifice No. is the indication to distinguish the valve seats usable at different operating pressures.

Configuration

JAH7.2R

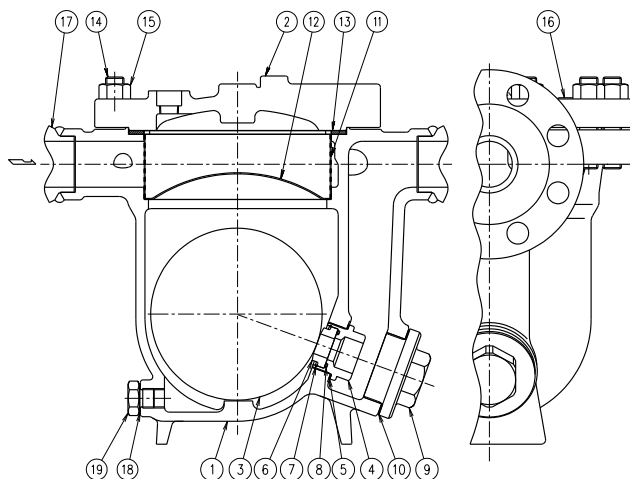

No.	Name	M*	R*	F*
1	Body			
2	Cover			
3	Float			✓
4	Valve Seat Holder		✓	
5	Valve Seat Holder Gasket	✓	✓	
6	Valve Seat		✓	
7	Snap Ring		✓	
8	Valve Seat O-ring	✓	✓	
9	Valve Seat Holder Plug			
10	Holder Plug Gasket	✓	✓	
11	Screen		✓	
12	Screen Holder			
13	Cover Gasket	✓	✓	
14	Cover Bolt			
15	Cover Nut			
16	Nameplate			
17	Flange / Socket			
18	Drain Plug Gasket	✓	✓	
19	Drain Plug			

JAH7.5R

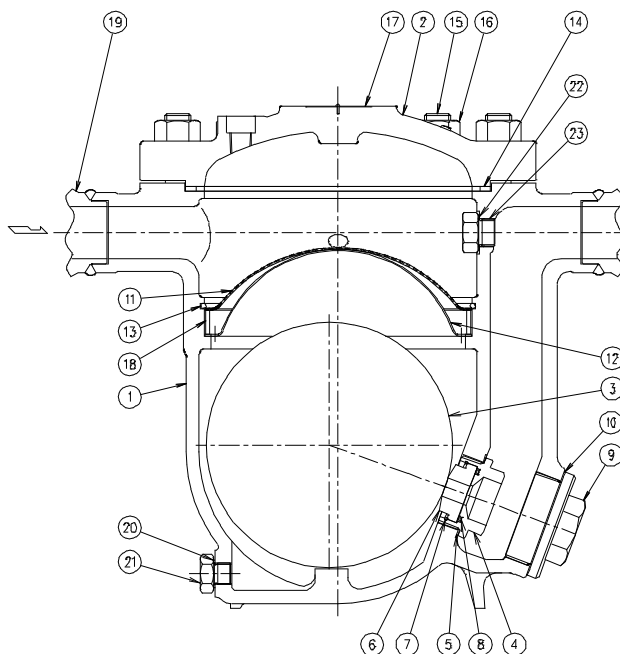

No.	Name	M*	R*	F*
1	Body			
2	Cover			
3	Float			✓
4	Valve Seat Holder		✓	
5	Valve Seat Holder Gasket	✓	✓	
6	Valve Seat		✓	
7	Snap Ring		✓	
8	Valve Seat O-ring	✓	✓	
9	Valve Seat Holder Plug			
10	Holder Plug Gasket	✓	✓	
11	Screen		✓	
12	Screen Holder			
13	Snap Ring			
14	Cover Gasket	✓	✓	
15	Cover Bolt			
16	Cover Nut			
17	Nameplate			
18	Screen Holder Retainer			
19	Flange / Socket			
20	Drain Plug Gasket	✓	✓	
21	Drain Plug			
22	Plug Gasket (Interior)	✓	✓	
23	Plug (Interior)			

*Replacement parts are available only in the following kits: M = Maintenance Kit, R = Repair Kit, F= Float

JAH8R

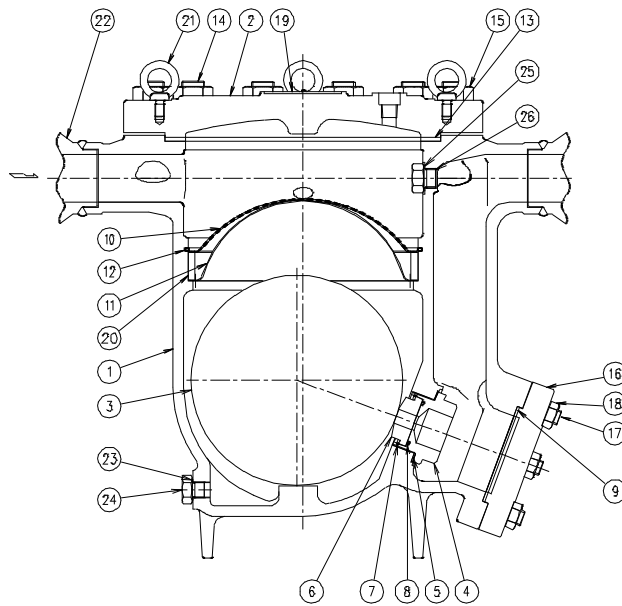

No.	Name	M*	R*	F*
1	Body			
2	Cover			
3	Float			✓
4	Valve Seat Holder		✓	
5	Valve Seat Holder Gasket	✓	✓	
6	Valve Seat		✓	
7	Snap Ring		✓	
8	Valve Seat O-ring	✓	✓	
9	Outlet Cover Gasket	✓	✓	
10	Screen		✓	
11	Screen Holder			
12	Snap Ring			
13	Cover Gasket	✓	✓	
14	Cover Bolt			
15	Cover Nut			
16	Outlet Cover			
17	Outlet Cover Bolt			
18	Outlet Cover Nut			
19	Nameplate			
20	Screen Holder Retainer			
21	Eye Bolt			
22	Flange / Socket			
23	Drain Plug Gasket	✓	✓	
24	Drain Plug			
25	Plug Gasket (Interior)	✓	✓	
26	Plug (Interior)			

*Replacement parts are available only in the following kits: M = Maintenance Kit, R = Repair Kit, F = Float

Installation



Install properly and **DO NOT** use this product outside the recommended operating pressure, temperature and other specification ranges. Improper use may result in such hazards as damage to the product or malfunctions which may lead to serious accidents. Local regulations may restrict the use of this product to below the conditions quoted.



Use hoisting equipment for heavy objects (weighing approximately 20 kg (44 lb) or more). Failure to do so may result in back strain or other injury if the object should fall.



Use the eye bolts for removing the cover only; **DO NOT** use the eye bolts for hoisting the product. Eye bolts may break under strain, possibly resulting in serious injury.



Take measures to prevent people from coming into direct contact with product outlets. Failure to do so may result in burns or other injury from the discharge of fluids.

Installation, inspection, maintenance, repairs, disassembly, adjustment and valve opening/closing should be carried out only by trained maintenance personnel.

1. Before installation, be sure to remove all protective seals.
2. Before installing the product, open the inlet valve and blow out the piping to remove any piping scraps, dirt and oil. Close the inlet valve after blowdown.
3. Install the product so the arrow on the body is pointing in the direction of flow.
4. The product should be inclined no more than 5° horizontally and front-to-back.
5. Install a condensate outlet valve and outlet piping.
6. To ensure proper condensate flow into the trap, install a pressure-balancing line. Connect the end of the pressure-balancing line to the air main or an area with an air pocket. For more details, see the section "The Need for a Pressure-balancing Line".
7. To facilitate inspection and maintenance, install a union or a flange where the product has connections (inlet, pressure-balancing line, condensate outlet). For more details, see the section "The Need for a Pressure-balancing Line".
8. Prime the trap with a small amount of water through the pressure-balancing port or line to ensure a seal. After priming and connecting the pressure-balancing line, open the inlet and outlet valves and check to make sure that the product functions properly.

If there is a problem, determine the cause using the "Troubleshooting" section in this manual.

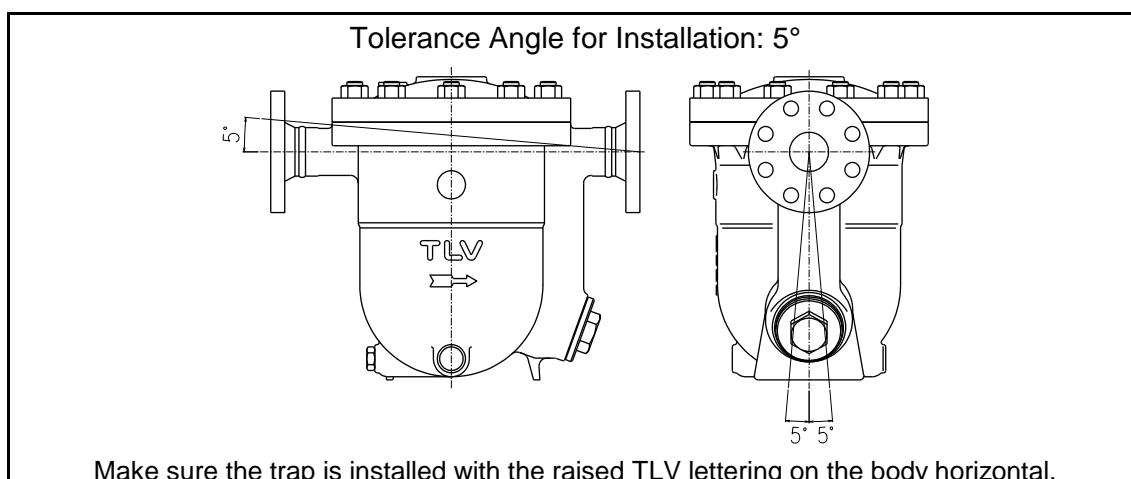

The Need for a Pressure-balancing Line

This air trap is designed to automatically discharge inflowing condensate. However, if the condensate completely fills the inlet path of the trap, air in the trap body will not be able to escape, preventing displacement by condensate, and thus preventing condensate from entering the trap. This phenomena is called air binding. Air binding occurs more often in piping with long horizontal lengths, smaller diameters or multiple bends. To prevent air binding and ensure air can be displaced by incoming condensate, a pressure-balancing line should be installed between the trap cover and the dry portion of the receiver tank or piping.

Connect the pressure-balancing line in the following manner:

Receiver Tank

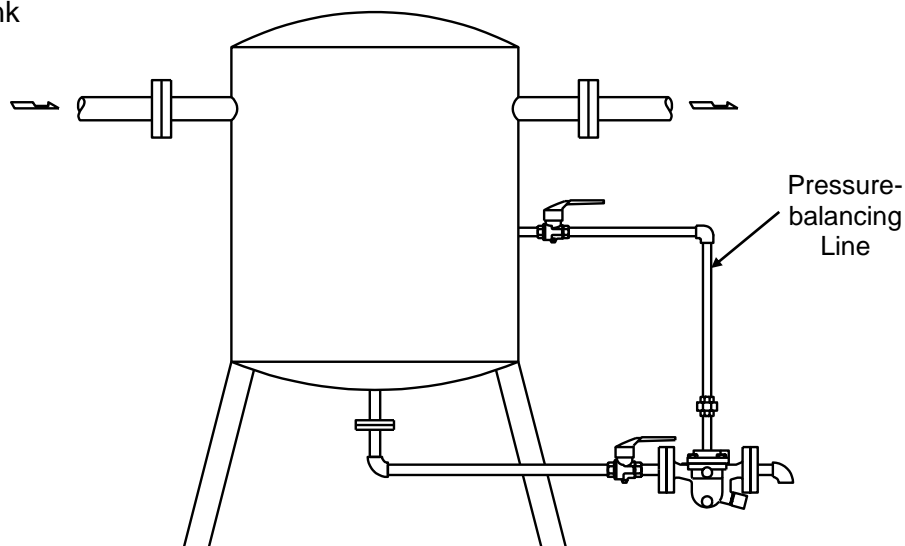

Air Main

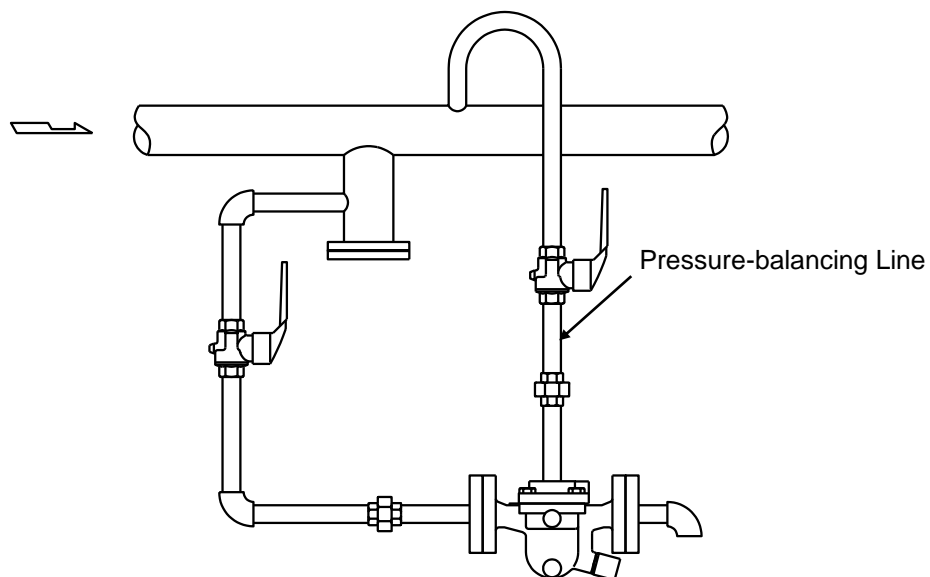

Maintenance



Take measures to prevent people from coming into direct contact with product outlets. Failure to do so may result in burns or other injury from the discharge of fluids.



Be sure to use only the recommended components when repairing the product, and NEVER attempt to modify the product in any way. Failure to observe these precautions may result in damage to the product or burns or other injury due to malfunction or the discharge of fluids.

Operational Check

A visual inspection of the following items should be done on a daily basis to determine whether the product is operating properly or has failed. Periodically (at least biannually) the operation should also be checked by using diagnostic equipment, such as a stethoscope or thermometer.

If the product should fail, it may cause damage to piping and equipment, resulting in faulty or low quality products or losses due to air leakage.

- Normal : Condensate is discharged continuously and the sound of flow can be heard. If there is very little condensate, there is almost no sound of flow.
- Blocked : No condensate is discharged.
(Discharge Impossible)
- Blowing : Air continually flows from the outlet and there is a continuous metallic sound.
- Air Leakage : Air is discharged through the product outlet together with condensate, accompanied by a high-pitched sound.

Parts Inspection

When parts have been removed, or during periodic inspections, use the following table to inspect the parts and replace any that are found to be defective.

Procedure	
Gaskets:	Check for warping or damage
Screen:	Check for clogging or corrosion
Valve Seat:	Check for warping or damage
Valve Seat Opening:	Check for dirt, oil film, wear or scratches
Float:	Check for scratches or dents
Body Interior:	Check for build-up

Disassembly/Reassembly

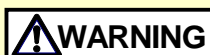

NEVER apply direct heat to the float. The float may explode due to increased internal pressure, causing accidents leading to serious injury or damage to property and equipment.

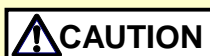

Use hoisting equipment for heavy objects (weighing approximately 20 kg (44 lb) or more). Failure to do so may result in back strain or other injury if the object should fall.

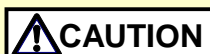

Use the eye bolts for removing the cover only; **DO NOT** use the eye bolts for hoisting the product. Eye bolts may break under strain, possibly resulting in serious injury.

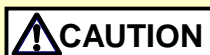

When disassembling or removing the product, wait until the internal pressure equals atmospheric pressure and the surface of the product has cooled to room temperature. Disassembling or removing the product when it is hot or under pressure may lead to discharge of fluids, causing burns, other injuries or damage.

Use the following procedures to remove components. Use the same procedures in reverse to reassemble.

(Installation, inspection, maintenance, repairs, disassembly, adjustment and valve opening/closing should be carried out only by trained maintenance personnel.)

Drain Plug

Part	During Disassembly	During Reassembly
Drain Plug	Remove with a socket wrench	Consult the table of tightening torques and tighten to the proper torque
Drain Plug Gasket	Remove the gasket and clean sealing surfaces	Replace with a new gasket; coat surfaces with anti-seize

Detaching / Reattaching the Cover and its Components

NOTE: Disconnect any lines that must be disconnected before disassembly can take place (inlet piping, pressure-balancing line, condensate discharge piping, etc.).

Part	During Disassembly	During Reassembly
Cover Nut	Remove with a socket wrench	Consult the table of tightening torques and tighten to the proper torque
Cover	Remove by lifting up and off	Make sure there are no pieces of the old gasket left on the sealing surfaces of the body and cover, align the arrows on the body and cover and reattach
Cover Gasket	Remove the gasket and clean sealing surfaces	Replace with a new gasket; make sure there are no pieces of the old gasket left on the sealing surfaces of the body and cover

Disassembly / Reassembly of Components Inside the Body (Removal of Float)

Part	JAH7.2R	JAH7.5R	JAH8R	During Disassembly	During Reassembly
Plug (Interior)	–	✓	✓	Remove with a socket wrench	Consult the table of tightening torques and tighten to the proper torque
Plug Gasket (Interior)	–	✓	✓	Remove the gasket and clean sealing surfaces	Replace with a new gasket; coat surfaces with anti-seize
Snap Ring	–	✓	✓	Using appropriate pliers, pinch insides together and remove	Insert securely into the groove in the body
Screen	✓	–	–	Lift straight up and out while turning	Place on the screen holder, making sure that the top of the screen does not stick up out of the body

Continued on the next page

Part	JAH7.2R	JAH7.5R	JAH8R	During Disassembly	During Reassembly
Screen	–	✓	✓	Remove by grasping the wire ring and lifting straight up and out	Set the screen on the screen holder and screen holder retainer and insert as far as the snap ring groove Make sure the correct side is facing up
Screen Holder Retainer	–	✓	✓	Remove by lifting up and out	Place on the screen holder without tilting
Screen Holder	✓	✓	✓	Remove without bending	Place on the ledge inside the body, making sure the rounded side is on top
Float	✓	✓	✓	Remove, being careful not to scratch the polished surface	Insert, being careful not to scratch or misshape

Disassembly / Reassembly of Components Inside the Body (Removal of Valve Seat)

Part	JAH7.2R	JAH7.5R	JAH8R	During Disassembly	During Reassembly
Valve Seat Holder Plug	✓	✓	–	Remove with a socket wrench	Consult the table of tightening torques and tighten to the proper torque
Outlet Cover Nut	–	–	✓	Remove with a socket wrench	Consult the table of tightening torques and tighten to the proper torque
Outlet Cover	–	–	✓	Remove, being careful not to scratch the gasket sealing surface	Make sure there are no pieces of the old gasket left on the sealing surfaces of the body and cover
Holder Plug Gasket	✓	✓	–	Remove the gasket and clean sealing surfaces	Replace with a new gasket; coat surfaces with anti-seize
Outlet Cover Gasket	–	–	✓	Remove the gasket and clean sealing surfaces	Replace with a new gasket; make sure there are no pieces of the old gasket left on the sealing surfaces of the body and cover
Valve Seat Holder	✓	✓	✓	Remove with a socket wrench	Consult the table of tightening torques and tighten to the proper torque
Valve Seat Holder Gasket	✓	✓	✓	Remove the gasket and clean sealing surfaces	Replace with a new gasket; coat surfaces with anti-seize
Snap Ring	✓	✓	✓	Using appropriate pliers, pinch insides together and remove (Fig. A)	Insert securely into groove up against the valve seat, be sure that the break in the snap ring lines up with the slot in the groove
Valve Seat	✓	✓	✓	Be careful not to scratch the sealing surfaces	Replace with a new valve seat if sealing surfaces are warped or damaged Push replacement valve seat in to insert
Valve Seat O-ring	✓	✓	✓	Be careful not to damage the O-ring as it is made of rubber	Coat with heat resistant grease*; replace with a new O-ring if warped or damaged; fit securely into the groove in the valve seat holder

*Use silicone grease (for heat resistant grease)

Fig A Valve Seat Holder

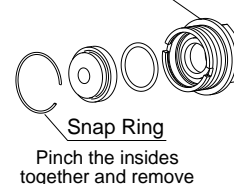

Table of Tightening Torques

Model	JAH7.2R		JAH7.5R		JAH8R			
Part Name	Torque		Distance Across Flats		Torque		Distance Across Flats	
	N·m	(lbf·ft)	mm	(in)	N·m	(lbf·ft)	mm	(in)
Drain Plug	100	(73)	26	(1)	100	(73)	26	(1)
Cover Nut	180	(130)	24	(¹⁵ / ₁₆)	200	(150)	30	(¹³ / ₁₆)
Plug (Interior)	—	—	—	—	150	(110)	27	(¹ / ₁₆)
Valve Seat Holder Plug	700	(510)	46	(¹³ / ₁₆)	800	(590)	46	(¹³ / ₁₆)
Outlet Cover Nut	—	—	—	—	—	—	160	(115)
Valve Seat Holder	350	(260)	38	(¹ / ₂)	600	(440)	46	(¹³ / ₁₆)

(1 N·m ≈ 10 kg·cm)

NOTE: -Coat all threaded portions with anti-seize.
 -If drawings or other special documentation were supplied for the product, any torque given there takes precedence over values shown here.

Exploded View

JAH7.2R / JAH7.5R (Parts indicated with "*" only come with JAH7.5R)

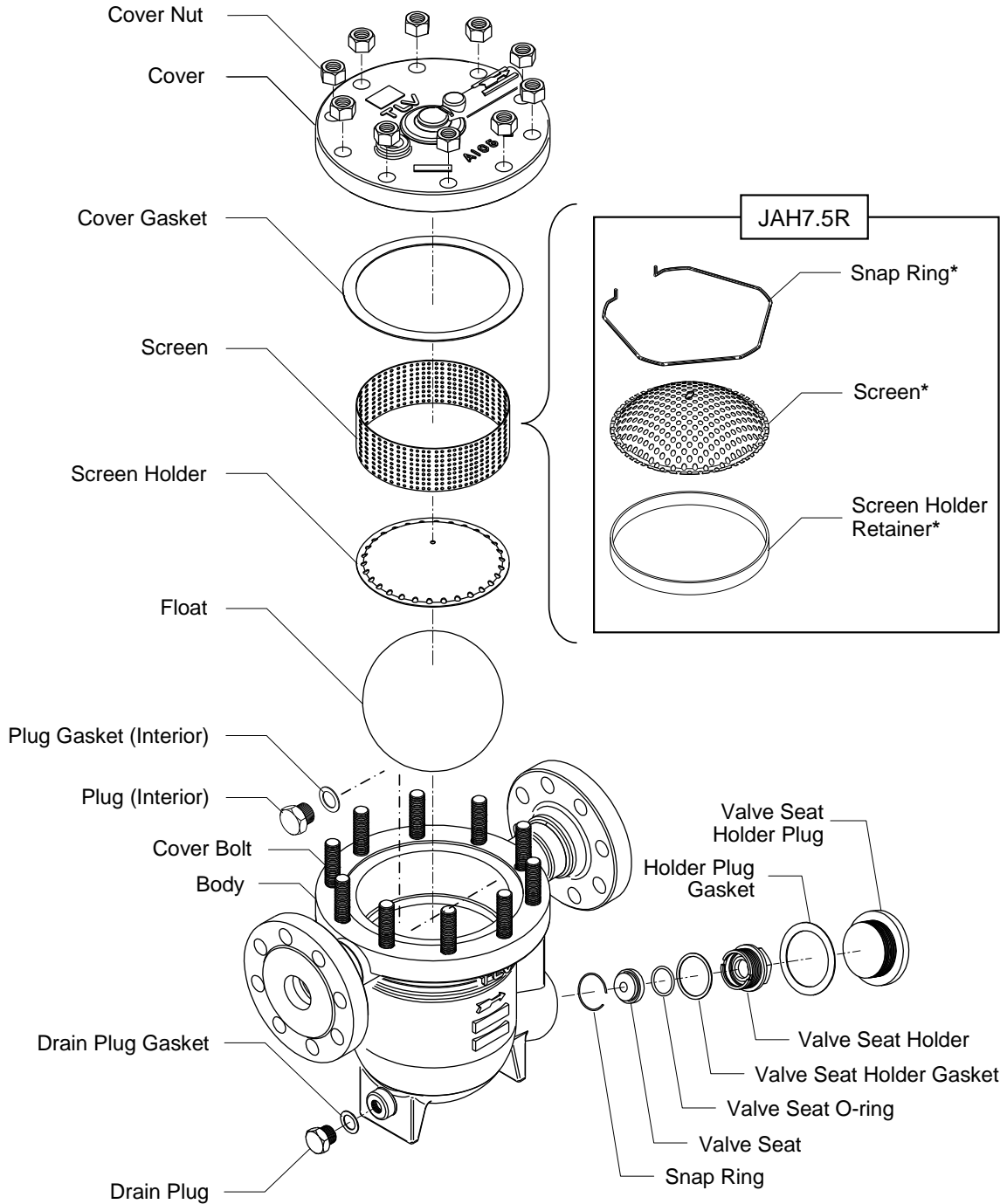

Exploded View

JAH8R

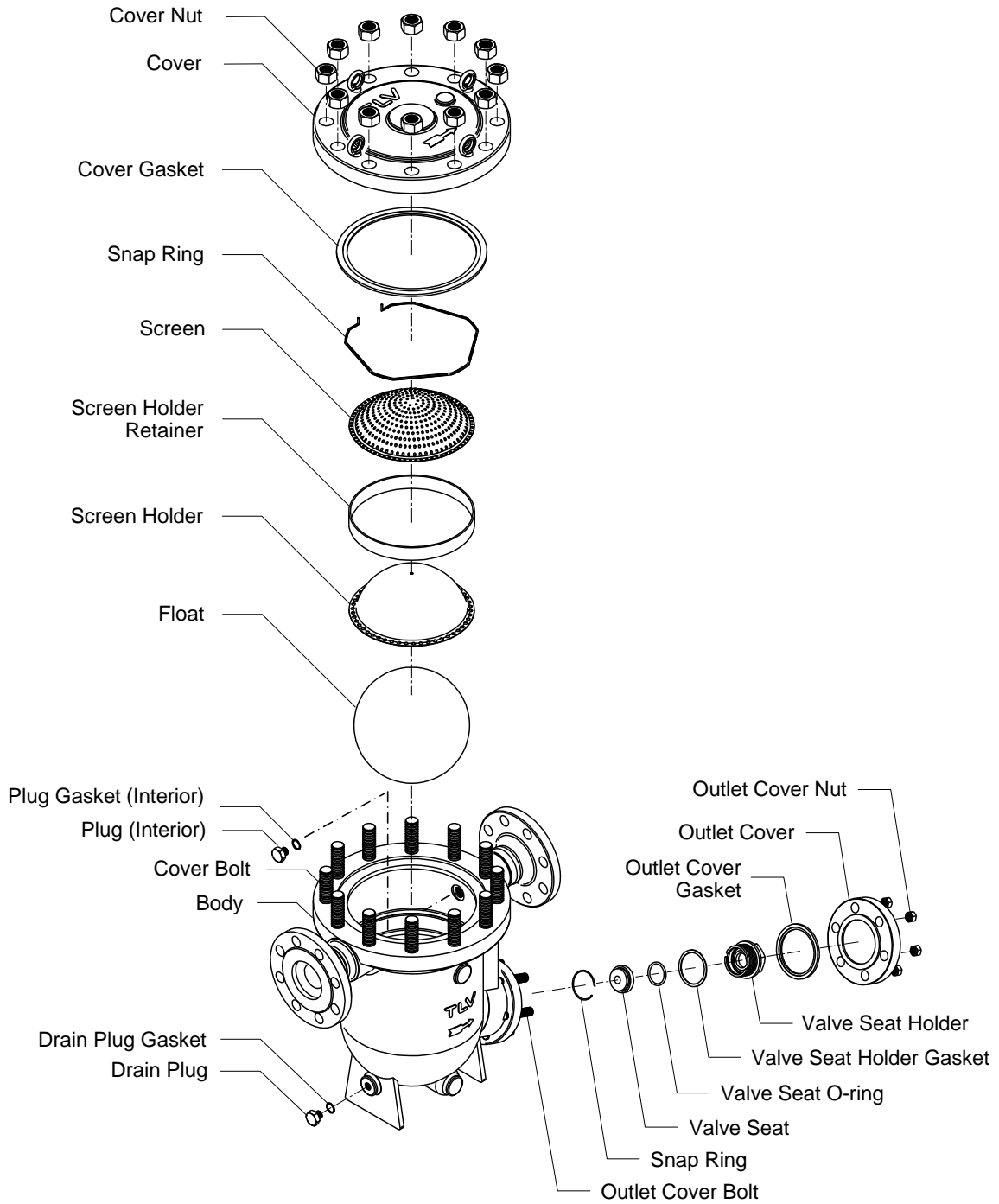

Instructions for Plug/Holder Disassembly and Reassembly

The seal on the threaded plugs/holders found on TLV products is formed by a flat metal gasket. There are various installation orientations for the gaskets, such as horizontal, diagonal and downward, and the gasket may be pinched in the thread recesses during assembly.

Instructions for Disassembly and Reassembly

1. Remove the plug/holder using a tool of the specified size (distance across flats).
2. The gasket should not be reused. Be sure to replace it with a new gasket.
3. Clean the gasket surfaces of the plug/holder and the product body using a rag and/or cleaning agents, then check to make sure the surfaces are not scratched or deformed.
4. Coat both the gasket surface of the plug/holder and the threads of the plug/holder with anti-seize, then press the gasket onto the center of the gasket surface of the plug/holder, making sure the anti-seize affixes the gasket tightly to the plug/holder. Check to make sure the gasket is not caught in the recesses of the threads.
5. Hold the plug/holder upside down to make sure that the anti-seize makes the gasket stick to the plug/holder even when the plug/holder is held upside down.
6. Screw the plug/holder by hand into the product body while making sure that the gasket remains tightly affixed to the center of the gasket surface of the plug/holder. Make sure the entire gasket is making contact with the gasket surface of the product body. It is important at this point to make sure the gasket is not pinched in the thread recesses of the plug/holder.
7. Tighten the plug/holder to the proper torque.
8. Next, begin the supply of air and check to make sure there is no leakage from the part just tightened. If there is leakage, immediately close the inlet valve and, if there is a bypass valve, take the necessary steps to release any residual pressure. After the surface of the product cools to room temperature, repeat the procedure beginning from step 1.

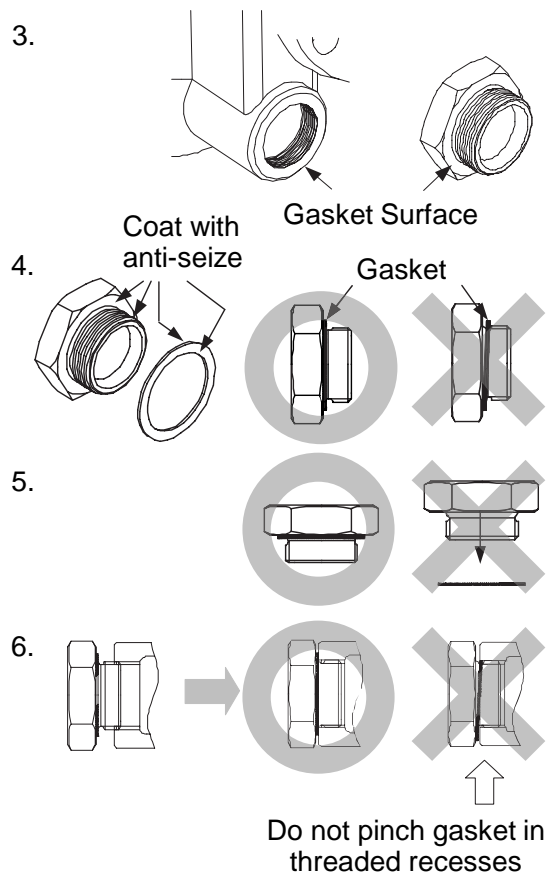

Troubleshooting



NEVER apply direct heat to the float. The float may explode due to increased internal pressure, causing accidents leading to serious injury or damage to property and equipment.



When disassembling or removing the product, wait until the internal pressure equals atmospheric pressure and the surface of the product has cooled to room temperature. Disassembling or removing the product when it is hot or under pressure may lead to discharge of fluids, causing burns, other injuries or damage.

When the product fails to operate properly, use the following table to locate the cause and remedy.

Problem	Cause	Remedy
No condensate is discharged (blocked) or discharge is poor	The float is damaged or filled with condensate	Replace with new float
	The valve seat opening, screen or piping are clogged with rust and scale	Clean parts
	The trap operating pressure exceeds the maximum specified pressure, or there is insufficient pressure differential between the trap inlet and outlet	Compare specifications and actual operating conditions
	Air binding has occurred	Make sure a pressure-balancing line is installed; if already installed, make sure it has not become dislodged or is not incorrectly installed
Air is discharged or leaks from the outlet* (blowing) (air leakage)	Clogged valve seat opening or rust and scale build-up beneath the float	Clean parts
	Scratches on the valve seat	Replace with new valve seat
	The float is misshapen or has a build-up	Clean float or replace with new float
	Improper installation orientation	Correct the installation
	Trap vibration	Lengthen the inlet piping and fasten it securely
	No condensate remains in the trap; there is no water-seal	Prime the air trap
Air is leaking from a place other than the outlet	Gasket deterioration or damage	Replace with new gasket(s)
	Improper tightening torques were used	Tighten to the proper torque
	Scratches on the sealing surfaces	If leaking continues even after replacing the gasket, replace the product
Float frequently becomes damaged	Water hammer has occurred	Study and correct the piping

* Make sure to maintain the Minimum Required Condensate Load, as air leaks may result if the inflowing condensate load falls below it.

(See the "Minimum Required Condensate Load" in the "Specifications" section.)

Option

The options shown below are available for this product on request. Please compare with the product you received.

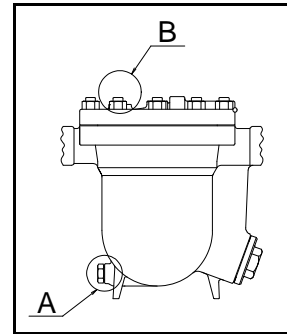

Options for Area A (Standard: with Drain Plug)

Without Drain Plug

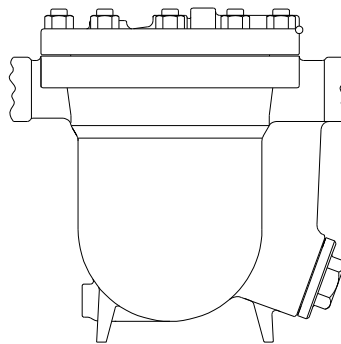

Options for Area B (Standard: Socket Weld)

Flange Type

Pressure-balancing Port

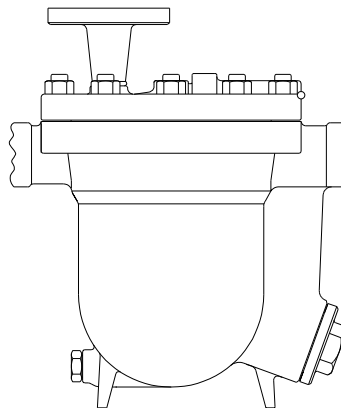

TLV EXPRESS LIMITED WARRANTY

Subject to the limitations set forth below, TLV Corporation, a North Carolina corporation (“**TLV**”) warrants that products which are sold by it, TLV CO., LTD., a Japanese corporation (“**TLVJ**”) or TLV International, Inc., a Japanese corporation (“**TII**”), (hereinafter the “**Products**”) are designed and manufactured by TLVJ, conform to the specifications published by TLV for the corresponding part numbers (the “**Specifications**”) and are free from defective workmanship and materials. With regard to products or components manufactured by unrelated third parties (the “**Components**”), TLV provides no warranty other than the warranty from the third party manufacturer(s), if any.

Exceptions to Warranty

This warranty does not cover defects or failures caused by:

1. improper shipping, installation, use, handling, etc., by other than TLV or service representatives authorized by TLV; or
2. dirt, scale or rust, etc.; or
3. improper disassembly and reassembly, or inadequate inspection and maintenance by other than TLV or service representatives authorized by TLV; or
4. disasters or forces of nature or Acts of God; or
5. abuse, abnormal use, accidents or any other cause beyond the control of TLV; or
6. improper storage, maintenance or repair; or
7. operation of the Products not in accordance with instructions issued with the Products or with accepted industry practices; or
8. use for a purpose or in a manner for which the Products were not intended; or
9. use of the Products in a manner inconsistent with the Specifications; or
10. use of the Products with Hazardous Fluids (fluids other than steam, air, water, nitrogen, carbon dioxide and inert gases (helium, neon, argon, krypton, xenon and radon)); or
11. failure to follow the instructions contained in the TLV Instruction Manual for the Product.

Duration of Warranty

This warranty is effective for a period of the earlier of: (i) three (3) years after delivery of Products to the first end user in the case of sealed SST-Series Products for use in steam pressure service up to 650 psig; (ii) two (2) years after delivery of Products to the first end user in the case of PowerTrap® units; or (iii) one (1) year after delivery of Products to the first end user in the case of all other Products. Notwithstanding the foregoing, asserting a claim under this warranty must be brought by the earlier of one of the foregoing periods, as applicable, or within five (5) years after the date of delivery to the initial buyer if not sold initially to the first end user.

ANY IMPLIED WARRANTIES NOT NEGATED HEREBY WHICH MAY ARISE BY OPERATION OF LAW, INCLUDING THE IMPLIED WARRANTIES OF MERCHANTABILITY AND FITNESS FOR A PARTICULAR PURPOSE AND ANY EXPRESS WARRANTIES NOT NEGATED HEREBY, ARE GIVEN SOLELY TO THE INITIAL BUYER AND ARE LIMITED IN DURATION TO ONE (1) YEAR FROM THE DATE OF SHIPMENT BY TLV.

Exclusive Remedy

THE EXCLUSIVE REMEDY UNDER THIS WARRANTY, UNDER ANY EXPRESS WARRANTY OR UNDER ANY IMPLIED WARRANTIES NOT NEGATED HEREBY (INCLUDING THE IMPLIED WARRANTIES OF MERCHANTABILITY AND FITNESS FOR A PARTICULAR PURPOSE), IS **REPLACEMENT**; PROVIDED: (a) THE CLAIMED DEFECT IS REPORTED TO TLV IN WRITING WITHIN THE APPLICABLE WARRANTY PERIOD, INCLUDING A DETAILED WRITTEN DESCRIPTION OF THE CLAIMED DEFECT AND HOW AND WHEN THE CLAIMED DEFECTIVE

PRODUCT WAS USED; AND (b) THE CLAIMED DEFECTIVE PRODUCT AND A COPY OF THE PURCHASE INVOICE IS RETURNED TO TLV, FREIGHT AND TRANSPORTATION COSTS PREPAID, UNDER A RETURN MATERIAL AUTHORIZATION AND TRACKING NUMBER ISSUED BY TLV. ALL LABOR COSTS, SHIPPING COSTS, AND TRANSPORTATION COSTS ASSOCIATED WITH THE RETURN OR REPLACEMENT OF THE CLAIMED DEFECTIVE PRODUCT ARE SOLELY THE RESPONSIBILITY OF BUYER OR THE FIRST END USER. TLV RESERVES THE RIGHT TO INSPECT ON THE FIRST END USER'S SITE ANY PRODUCTS CLAIMED TO BE DEFECTIVE BEFORE ISSUING A RETURN MATERIAL AUTHORIZATION. SHOULD SUCH INSPECTION REVEAL, IN TLV'S REASONABLE DISCRETION, THAT THE CLAIMED DEFECT IS NOT COVERED BY THIS WARRANTY, THE PARTY ASSERTING THIS WARRANTY SHALL PAY TLV FOR THE TIME AND EXPENSES RELATED TO SUCH ON-SITE INSPECTION.

Exclusion of Consequential and Incidental Damages

IT IS SPECIFICALLY ACKNOWLEDGED THAT THIS WARRANTY, ANY OTHER EXPRESS WARRANTY NOT NEGATED HEREBY, AND ANY IMPLIED WARRANTY NOT NEGATED HEREBY, INCLUDING THE IMPLIED WARRANTIES OF MERCHANTABILITY AND FITNESS FOR A PARTICULAR PURPOSE, DO NOT COVER, AND NEITHER TLV, TII NOR TLVJ WILL IN ANY EVENT BE LIABLE FOR, INCIDENTAL OR CONSEQUENTIAL DAMAGES, INCLUDING, BUT NOT LIMITED TO LOST PROFITS, THE COST OF DISASSEMBLY AND SHIPMENT OF THE DEFECTIVE PRODUCT, INJURY TO OTHER PROPERTY, DAMAGE TO BUYER'S OR THE FIRST END USER'S PRODUCT, DAMAGE TO BUYER'S OR THE FIRST END USER'S PROCESSES, LOSS OF USE, OR OTHER COMMERCIAL LOSSES. WHERE, DUE TO OPERATION OF LAW, CONSEQUENTIAL AND INCIDENTAL DAMAGES UNDER THIS WARRANTY, UNDER ANY OTHER EXPRESS WARRANTY NOT NEGATED HEREBY OR UNDER ANY IMPLIED WARRANTY NOT NEGATED HEREBY (INCLUDING THE IMPLIED WARRANTIES OF MERCHANTABILITY AND FITNESS FOR A PARTICULAR PURPOSE) CANNOT BE EXCLUDED, SUCH DAMAGES ARE EXPRESSLY LIMITED IN AMOUNT TO THE PURCHASE PRICE OF THE DEFECTIVE PRODUCT. THIS EXCLUSION OF CONSEQUENTIAL AND INCIDENTAL DAMAGES, AND THE PROVISION OF THIS WARRANTY LIMITING REMEDIES HEREUNDER TO REPLACEMENT, ARE INDEPENDENT PROVISIONS, AND ANY DETERMINATION THAT THE LIMITATION OF REMEDIES FAILS OF ITS ESSENTIAL PURPOSE OR ANY OTHER DETERMINATION THAT EITHER OF THE ABOVE REMEDIES IS UNENFORCEABLE, SHALL NOT BE CONSTRUED TO MAKE THE OTHER PROVISIONS UNENFORCEABLE.

Exclusion of Other Warranties

THIS WARRANTY IS IN LIEU OF ALL OTHER WARRANTIES, EXPRESS OR IMPLIED, AND ALL OTHER WARRANTIES, INCLUDING BUT NOT LIMITED TO THE IMPLIED WARRANTIES OF MERCHANTABILITY AND FITNESS FOR A PARTICULAR PURPOSE, ARE EXPRESSLY DISCLAIMED.

Severability

Any provision of this warranty which is invalid, prohibited or unenforceable in any jurisdiction shall, as to such jurisdiction, be ineffective to the extent of such invalidity, prohibition or unenforceability without invalidating the remaining provisions hereof, and any such invalidity, prohibition or unenforceability in any such jurisdiction shall not invalidate or render unenforceable such provision in any other jurisdiction.

TLV CORPORATION

13901 South Lakes Drive, Charlotte, NC 28273-6790, U.S.A.
Tel: [1]-704-597-9070 Fax: [1]-704-583-1610