



Manufacturer

TLV CO., LTD.
Kakogawa, Japan
is approved by LRDA Ltd. to ISO 9001/14001



Instruction Manual

Cycle Counter

C1CM / C1CF

C1CM-EX / C1CF-EX

C1SM / C1SF

C1SM-EX / C1SF-EX

(Standard Model)

(cULus Intrinsically Safe Model)

NOTE: This instruction manual has been edited for use with both standard and intrinsically safe models. Since UL requires safety cautions to be written both in English and French for UL explosion proof approved products, this instruction manual has been edited accordingly.

Introduction

Thank you for purchasing the TLV cycle counter.

This product has been thoroughly inspected before being shipped from the factory. When the product is delivered, before doing anything else, check the specifications and external appearance to make sure nothing is out of the ordinary. Also be sure to read this manual carefully before use and follow the instructions to be sure of using the product properly.

For products with special order specifications or options, if detailed instructions for the special order specifications or options are not contained in this manual, please contact TLV for full details.

This instruction manual is intended for use with the model(s) listed on the front cover. It is necessary not only for installation but for subsequent maintenance, disassembly/reassembly and troubleshooting. Please keep it in a safe place for future reference.

Manufacturer



881 Nagasuna, Noguchi, Kakogawa, Hyogo, 675-8511, Japan
Tel: [81]-(0)79-422-1122 Fax: [81]-(0)79-422-0112

Copyright © 2021 by TLV CO., LTD. All rights reserved

TLV CORPORATION





Contents





Safety Considerations	1
Règles de sécurité	3
Operation	5
Specifications	6
Configuration	8
Installation	9
Troubleshooting	13
Control Drawing	15
TLV EXPRESS LIMITED WARRANTY	16

Safety Considerations

- Read this section carefully before use and be sure to follow the instructions.
- Installation, inspection, maintenance, repairs, disassembly, adjustment and valve opening/closing should be carried out only by trained maintenance personnel.
- The precautions listed in this manual are designed to ensure safety and prevent equipment damage and personal injury. For situations that may occur as a result of erroneous handling, three different types of cautionary items are used to indicate the degree of urgency and the scale of potential damage and danger: DANGER, WARNING and CAUTION.
- The three types of cautionary items above are very important for safety: be sure to observe all of them as they relate to installation, use, maintenance, and repair. Furthermore, TLV accepts no responsibility for any accidents or damage occurring as a result of failure to observe these precautions.

Symbols

	Indicates a DANGER, WARNING or CAUTION item.
	Indicates an urgent situation which poses a threat of death or serious injury
	Indicates that there is a potential threat of death or serious injury
	Indicates that there is a possibility of injury or equipment/product damage

 WARNING	<p>C1CM, C1SM, C1CF, and C1SF have not been evaluated by UL LLC.</p> <p>Use only the intrinsically safe C1CM-EX, C1SM-EX, C1CF-EX, and C1SF-EX in hazardous areas. Product markings are provided on the nameplate attached on the product.</p> <p>The C1CM-EX, C1SM-EX, C1CF-EX, and C1SF-EX meet the following standards for intrinsic safety: C1CM-EX, C1CF-EX</p>  <p>Class I, Zone1, AEx ib IIB T3/T2 Class I, Zone1, Ex ib IIB T3/T2</p> <p>C1SM-EX, C1SF-EX</p>  <p>Class I, Zone1, AEx ib IIC T3/T2 Class I, Zone1, Ex ib IIC T3/T2</p> <p>For hazardous areas, the product should be selected and installed by trained personnel with knowledge of the hazardous locations/classifications.</p> <p>When using the product in hazardous area, please connect it to the earth in order to avoid the ignition from electrostatic charge.</p> <p>Models GP10, GP10L, GP10M, GP14, GP14L, GP14M, GP10F and GP21F and usage of the Cycle Counters with these PowerTrap models have not been evaluated by UL LLC.</p>
 CAUTION	<p>Install properly and DO NOT use this product outside the recommended operating pressure, temperature and other specification ranges.</p> <p>Improper use may result in such hazards as damage to the product or malfunctions that may lead to serious accidents. Local regulations may restrict the use of this product to below the conditions quoted.</p> <p>Make sure that the sensor body is properly tightened. Insufficient tightening may allow steam to blow out, resulting in burns.</p> <p>When disassembling or removing the product, wait until the internal pressure of the PowerTrap equals atmospheric pressure and the surface of the PowerTrap has cooled to room temperature. Disassembling or removing the product when it is hot or under pressure may lead to discharge of fluids, causing burns, other injuries or damage.</p> <p>NEVER attempt to modify the product in any way. Failure to observe these precautions may result in damage to the product and burns or other injury due to malfunction or the discharge or fluids.</p> <p>Use only under conditions in which no water hammer will occur. The impact of water hammer may damage the product, leading to fluid discharge, which may cause burns or other injury.</p> <p>When installing the product, use the appropriate tool such as an adjustable wrench. Using the improper tool may lead to injury or damage to the product.</p> <p>DO NOT disassemble/modify the product. This could damage the product and/or the built-in battery, or cause leakage of battery fluid, leading to burns or other injury. Battery cells are not user replaceable.</p>

Règles de sécurité

- Lire attentivement cette notice avant l'utilisation et suivre les instructions.
- Toute installation, inspection, entretien, réparation, démontage, ajustement et ouverture/fermeture de vanne doit être fait uniquement par une personne formée à l'entretien.
- Les précautions reprises dans ce manuel ont pour but de garantir la sécurité et de prévenir tout dommage matériel et blessure humaine. Pour les situations potentiellement dangereuses qui pourraient survenir à la suite d'un maniement impropre, trois types de signaux sont utilisés pour indiquer le degré d'urgence et de dégât potentiel: DANGER, AVERTISSEMENT et ATTENTION.
- Les trois types de symboles énumérés ci-dessous sont très importants pour votre sécurité: n'oubliez pas de les respecter, car ils concernent aussi bien l'installation et l'utilisation que l'entretien et les réparations. D'autre part, TLV n'accepte aucune responsabilité pour tout accident ou dégât survenant à la suite d'un non-respect de ces précautions.

Symboles

   	<p>Indique un signal DANGER, AVERTISSEMENT ou ATTENTION.</p> <p>DANGER Indique une situation d'urgence avec risque de mort ou de blessure grave.</p> <p>AVERTISSEMENT Indique une situation pouvant entraîner la mort ou des blessures graves.</p> <p>ATTENTION Indique un risque de blessure ou de dégât matériel au produit et/ou aux installations.</p>
	<p>Les modèles C1CM, C1SM, C1CF et C1SF n'ont pas été évalués par UL LLC.</p> <p>Dans les zones dangereuses, n'utilisez que les modèles à sécurité intrinsèque C1CM-EX, C1SM-EX, C1CF-EX et C1SF-EX. Le nom complet du modèle est inscrit sur la plaquette signalétique du produit. Les modèles C1CM-EX, C1SM-EX, C1CF-EX et C1SF-EX respectent les normes de sécurité intrinsèque suivantes:</p> <p>C1CM-EX, C1CF-EX</p>  <p>Class I, Zone1, AEx ib IIB T3/T2 Class I, Zone1, Ex ib IIB T3/T2</p> <p>C1SM-EX, C1SF-EX</p>  <p>Class I, Zone1, AEx ib IIC T3/T2 Class I, Zone1, Ex ib IIC T3/T2</p> <p>La sélection et l'installation de produits dans les zones dangereuses doivent être effectuées par du personnel qualifié qui connaît bien les zones dangereuses et leurs classifications.</p> <p>Lorsque vous utilisez ce produit dans une zone dangereuse, veuillez relier le produit à la terre pour éviter tout allumage dû à une charge électrostatique. Les modèles GP10, GP10L, GP10M, GP14, GP14L, GP14M, GP10F et GP21F ainsi que leur utilisation avec le compteur de cycles n'ont pas été évalués par UL LLC.</p>
	<p>Installer le produit correctement et NE PAS l'utiliser en dehors de la pression et de la température maximales de fonctionnement, ni en dehors des autres plages spécifiées.</p> <p>Une telle utilisation peut entraîner des dommages au produit ou des dysfonctionnements, ce qui peut provoquer des brûlures ou autres blessures. Il se peut que des règlements locaux limitent l'utilisation du produit en-deçà des spécifications indiquées.</p>

Suite à la page suivante

 ATTENTION	<p>Assurez-vous que le corps de la sonde soit vissé à fond. S'il n'est pas vissé à fond, il se peut que de la vapeur s'échappe et provoque des brûlures.</p>
	<p>En cas de démontage ou de manipulation du produit, attendre que la pression interne du PowerTrap soit égale à la pression atmosphérique et que la surface du PowerTrap soit complètement refroidie. Le démontage ou la manipulation du produit lorsqu'il est chaud ou sous pression peut provoquer la fuite d'un fluide et entraîner des brûlures, des dommages ou autres blessures.</p>
	<p>N'essayez JAMAIS de modifier le produit. Si vous n'observez pas ces consignes, vous pouvez endommager le produit ou provoquer des blessures/brûlures dues au mauvais fonctionnement de l'appareil ou la fuite d'un fluide.</p>
	<p>Utiliser le produit dans des conditions où il n'y a aucun coup de bélier. L'impact d'un coup de bélier peut endommager le produit et provoquer l'écoulement des fluides, ainsi que des brûlures ou des blessures graves.</p>
	<p>Lors de l'installation du produit, utilisez un outil adapté tel qu'une clé à ouverture variable. L'utilisation d'un outil non adapté à la tâche peut provoquer des blessures ou endommager le produit.</p>
	<p>NE démontez NI modifiez le produit. Ceci peut endommager le produit ou la pile intégrée et/ou causer une fuite du liquide à l'intérieur de la pile, ce qui peut provoquer des brûlures ou autres blessures. La pile n'est pas remplaçable.</p>

Operation

Cycle counter is a counter designed for use with GP series TLV PowerTraps. Cycle counter registers each cycling of the PowerTrap by using its sensor arm to detect the vertical movement of the PowerTrap's internal float. When the contact points of the reed switch inside the counter body (or the switch unit) connect, each cycling of the PowerTrap is counted.

There are two different types of cycle counter available.

Counter Unit Type (with a built-in LCD display) (C1CM/C1CM-EX, C1CF/C1CF-EX)

This type includes a built-in LCD display to display the number of pump cycles of the PowerTrap. Install the cycle counter using the installation hole on the PowerTrap.

•Installation location

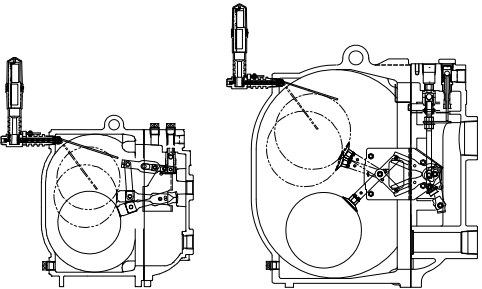
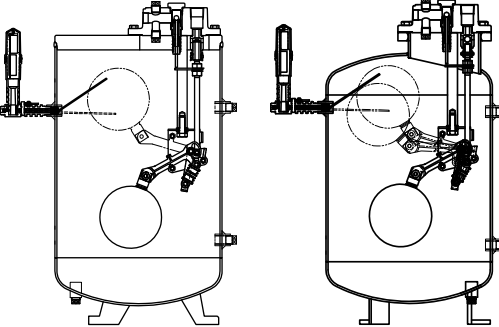
C1CM/C1CM-EX	C1CF/C1CF-EX
	
GP10, GP10L, GP10M GP14, GP14L, GP14M	GP10F* GP21F*

Terminal Box Type (no display) (C1SM/C1SM-EX, C1SF/C1SF-EX)

There is no display on this type. Use the product with a separately prepared self-powered counter, etc.

•Installation location

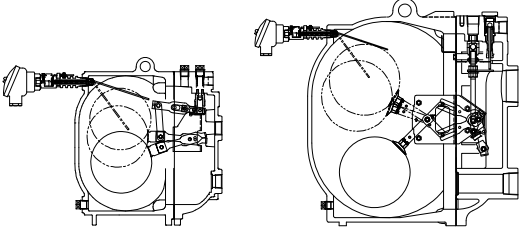
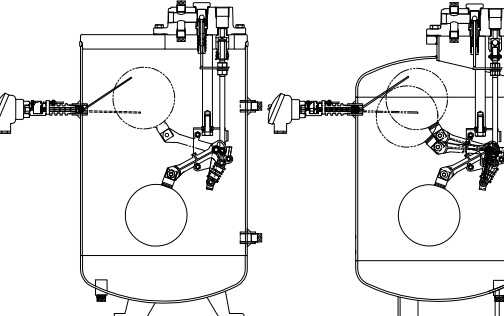
C1SM/C1SM-EX	C1SF/C1SF-EX
	
GP10, GP10L, GP10M GP14, GP14L, GP14M	GP10F* GP21F*

NOTE	<p>Cycle counter protrudes from the PowerTrap body when installed on the PowerTrap. Make sure to maintain sufficient installation space as described in the instruction manual for the PowerTrap. Do not put extra force onto the cycle counter when lifting the PowerTrap up (for disassembly or maintenance, etc.).</p>
------	---

*Only available in some countries.

Specifications



Install properly and **DO NOT** use this product outside the recommended operating pressure, temperature and other specification ranges. Improper use may result in such hazards as damage to the product or malfunctions which may lead to serious accidents. Local regulations may restrict the use of this product to below the conditions quoted.



Installer le produit correctement et **NE PAS** l'utiliser en dehors de la pression et de la température maximales de fonctionnement, ni en dehors des autres plages spécifiées. Une telle utilisation peut entraîner des dommages au produit ou des dysfonctionnements, ce qui peut provoquer des brûlures ou autres blessures. Il se peut que des règlements locaux limitent l'utilisation du produit en-deçà des spécifications indiquées.

C1C Series

Model	Counter Unit Type*4			
	Standard Model		Intrinsically Safe Model	
	C1CM	C1CF	C1CM-EX	C1CF-EX
Installable PowerTrap Models	GP10, GP14, GP10L, GP14L, GP10M, GP14M	GP10F GP21F	GP10, GP14, GP10L, GP14L, GP10M, GP14M	GP10F GP21F
Connection	Screwed R(PT) or NPT			
Size	15 mm (1/2 in)			
Maximum Operating Pressure (PMO)*1/ Maximum Operating Temp. (TMO)*1	2.1 MPaG / 220 °C (300 psig / 428 °F)			
Maximum Allowable Pressure (PMA)*2/ Maximum Allowable Temp. (TMA)*2	2.1 MPaG/ 260 °C (300 psig / 500 °F)			
Applicable Fluids*3	Steam Condensate, Water, Steam, Air, Nitrogen			
Protection Class	IP 65			
Ambient Pressure / Temperature	Atmospheric / -10 to 55 °C (14 to 131 °F)			

Continued on the next page

Model	Counter Unit Type*4	
Process Temperature	—	T3: 185 °C (365 °F) T2: 220 °C (428 °F)
Intrinsically Safe: Certified to meet all of these standards	—	 Class I, Zone1, AEx ib IIB T3/T2 Class I, Zone1, Ex ib IIB T3/T2
Display	8-digit display LCD (can be reset*5)	
Power Supply	Special built-in lithium battery (3.6 V) Battery life: Approx. 10 years (Battery not replaceable*4)	
Weight	Approx. 660 g (1.45 lbs)	
Accessories	Counter Resetter	

- *1 Maximum Operating Pressure (PMO) and Maximum Operating Temperature (TMO) are operating conditions for the inserted portion only.
- *2 Maximum allowable pressure (PMA) and maximum allowable temperature (TMA) are DESIGN CONDITIONS FOR THE INSERTED PORTION, **NOT** OPERATING CONDITIONS.
- *3 Do not use with toxic, flammable or otherwise hazardous fluids.
- *4 Repair parts are not supplied. Once the battery is depleted the entire unit must be replaced as the battery for the counter unit cannot be taken out or replaced. In addition, as a used counter unit still contains its built-in battery, please return the unit to TLV or follow local regulations for disposal.
- *5 Once the counter is reset, the previous value is lost and cannot be recovered.

GP10, GP10L GP10M, GP14, GP14L and GP14M cannot be equipped with a cycle counter and a level gauge simultaneously but GP10F and GP21F can. GP10F and GP21F are only available in some countries.

C1S Series

Model	Terminal Box Type*4			
	Standard Model		Intrinsically Safe Model	
	C1SM	C1SF	C1SM-EX	C1SF-EX
Installable PowerTrap Models	GP10, GP14, GP10L, GP14L, GP10M, GP14M	GP10F GP21F	GP10, GP14, GP10L, GP14L, GP10M, GP14M	GP10F GP21F
Connection	Screwed R(PT) or NPT			
Size	15 mm (1/2 in)			
Maximum Operating Pressure (PMO)*1/ Maximum Operating Temp. (TMO)*1	2.1 MPaG / 220 °C (300 psig / 428 °F)			
Maximum Allowable Pressure (PMA)*2/ Maximum Allowable Temp. (TMA)*2	2.1 MPaG/ 260 °C (300 psig / 500 °F)			
Applicable Fluids*3	Steam Condensate, Water, Steam, Air, Nitrogen			
Protection Class	IP 65*5			
Ambient Pressure / Temperature	Atmospheric/ -45 to 90 °C (-49 to 194 °F)		Atmospheric/ -20 to 80 °C (-4 to 176 °F)	
Process Temperature	—		T3: 185 °C (365 °F) T2: 220 °C (428 °F)	
Intrinsically Safe: Certified to meet all of these standards	—		 Class I, Zone1, AEx ib IIC T3/T2 Class I, Zone1, Ex ib IIC T3/T2	
Display	—			
Power Supply	Max. incoming voltage (Ui): 28V Max. incoming current (Ii): 120 mA Max. input power (Pi): 1W Max. internal capacitance (Ci): 3nF Max. internal inductance (Li): 0			
Model	Counter Unit Type*4			
Weight	Approx. 700 g (1.54 lbs)			
Accessories	—			

*1 Maximum Operating Pressure (PMO) and Maximum Operating Temperature (TMO) are operating conditions for the inserted portion only.

*2 Maximum allowable pressure (PMA) and maximum allowable temperature (TMA) are DESIGN CONDITIONS FOR THE INSERTED PORTION, **NOT** OPERATING CONDITIONS.

*3 Do not use with toxic, flammable or otherwise hazardous fluids.

*4 Repair parts are not supplied.

*5 Waterproofing of the wiring inlet should be carried out by the user using a waterproof cable gland, etc.

GP10, GP10L GP10M, GP14, GP14L and GP14M cannot be equipped with a cycle counter and a level gauge simultaneously but GP10F and GP21F can. GP10F and GP21F are only available in some countries.

Configuration

•Counter Unit Type (C1CM/C1CM-EX, C1CF/C1CF-EX)

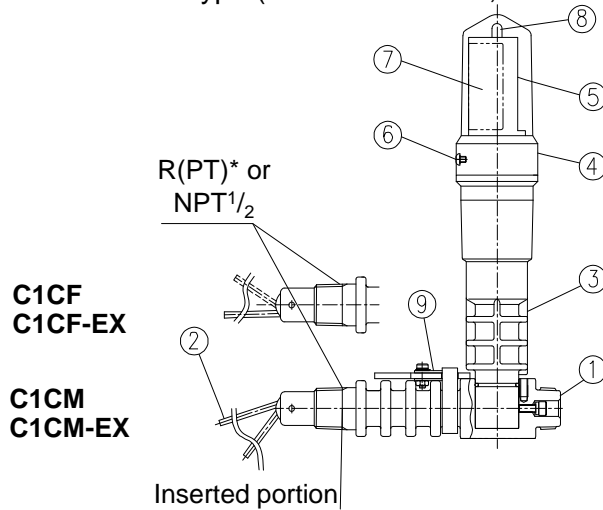

*R(PT) is equivalent to BSPT

No.	Name
1	Sensor Body
2	Sensor Arm
3	Counter Body
4	Cap
5	Display (LCD)
6	Hex Socket Head Bolt
7	Nameplate
8	LED
9	Magnet Booster Kit

Cycle Counter cannot be installed on GP series PowerTraps insulated with an insulation thickness exceeding 40 mm (1½ in).

•Terminal Box Type (C1SM/C1SM-EX, C1SF/C1SF-EX)

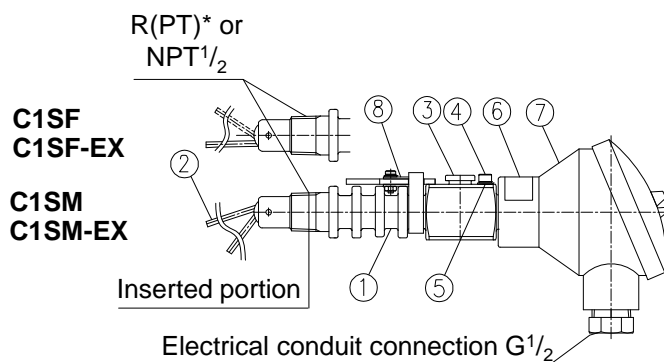

*R(PT) is equivalent to BSPT

No.	Name
1	Sensor Body
2	Sensor Arm
3	Switch Unit
4	Hex Socket Head Bolt
5	Washer
6	Nameplate
7	Terminal Box
8	Magnet Booster Kit

Cycle Counter cannot be installed on GP series PowerTraps insulated with an insulation thickness exceeding 40 mm (1½ in).

Installation



WARNING

C1CM, C1SM, C1CF, and C1SF have not been evaluated by UL LLC. Use only the intrinsically safe C1CM-EX, C1SM-EX, C1CF-EX and C1SF-EX in hazardous areas. For hazardous areas, the product should be selected and installed by trained personnel with knowledge of the hazardous locations/classifications.



AVERTISSEMENT

Les modèles C1CM, C1SM, C1CF et C1SF n'ont pas été évalués par UL LLC. Dans les zones dangereuses, n'utilisez que les modèles à sécurité intrinsèque C1CM-EX, C1SM-EX, C1CF-EX et C1SF-EX. La sélection et l'installation de produits dans les zones dangereuses doivent être effectuées par du personnel qualifié qui connaît bien les zones dangereuses et leurs classifications.



CAUTION

Install properly and DO NOT use this product outside the recommended operating pressure, temperature and other specification ranges. Improper use may result in such hazards as damage to the product or malfunctions which may lead to serious accidents. Local regulations may restrict the use of this product to below the conditions quoted.



ATTENTION

Installer le produit correctement et NE PAS l'utiliser en dehors de la pression et de la température maximales de fonctionnement, ni en dehors des autres plages spécifiées. Une telle utilisation peut entraîner des dommages au produit ou des dysfonctionnements, ce qui peut provoquer des brûlures ou autres blessures. Il se peut que des règlements locaux limitent l'utilisation du produit en-deçà des spécifications indiquées.



CAUTION

Use only under conditions in which no water hammer will occur. The impact of water hammer may damage the product, leading to fluid discharge, which may cause burns or other injury.



ATTENTION

Utiliser le produit dans des conditions où il n'y a aucun coup de bélier. L'impact d'un coup de bélier peut endommager le produit et provoquer l'écoulement des fluides, ainsi que des brûlures ou des blessures graves.



CAUTION

NEVER attempt to modify the product in any way. Failure to observe these precautions may result in damage to the product and burns or other injury due to malfunction or the discharge of fluids.



ATTENTION

N'essayez JAMAIS de modifier le produit. Si vous n'observez pas ces consignes, vous pouvez endommager le produit ou provoquer des blessures/brulures dues au mauvais fonctionnement de l'appareil ou la fuite d'un fluide.



CAUTION

Make sure that the sensor body is properly tightened. Insufficient tightening may allow steam to blow out, resulting in burns.



ATTENTION

Assurez-vous que le corps de la sonde soit vissé à fond. S'il n'est pas vissé à fond, il se peut que de la vapeur s'échappe et provoque des brulures.



CAUTION

When disassembling or removing the product, wait until the internal pressure of the PowerTrap equals atmospheric pressure and the surface of the PowerTrap has cooled to room temperature. Disassembling or removing the product when it is hot or under pressure may lead to discharge of fluids, causing burns, other injuries or damage.



ATTENTION

En cas de démontage ou de manipulation du produit, attendre que la pression interne du PowerTrap soit égale à la pression atmosphérique et que la surface du PowerTrap soit complètement refroidie. Le démontage ou la manipulation du produit lorsqu'il est chaud ou sous pression peut provoquer la fuite d'un fluide et entraîner des brulures, des dommages ou autres blessures.

Installation, inspection, maintenance, repairs, disassembly, adjustment and valve opening/closing should be carried out only by trained maintenance personnel.

An explanation for installing cycle counter onto the GP14M PowerTrap is given as an example. The same procedure should be followed for other models.

1. Remove the plug from the PowerTrap in reference with the installation position in the "Operation" section. Screw the cycle counter into the place where the plug has been removed on the PowerTrap by turning it clockwise 4 to 5 times.

NOTE	<ul style="list-style-type: none"> - Wrap the threaded portion of the sensor body with sealing tape for screwing into the PowerTrap. Ensure not to wrap the tape around any part of the sensor body other than the threaded portion. The cycle counter may not operate properly if tape is wrapped around a moving part such as the sensor arm. - Do not use sealant. If sealant adheres to the moving part of the sensor arm it may interfere with the arm's movement.
------	---

NOTE	<p>Sometimes the display on the counter unit type does not show "0" when delivered. The number can be reset after installation. Reset as needed. (Refer to the "Resetting the counter on the LCD display of the counter unit type" section described later in this manual.)</p>
------	---

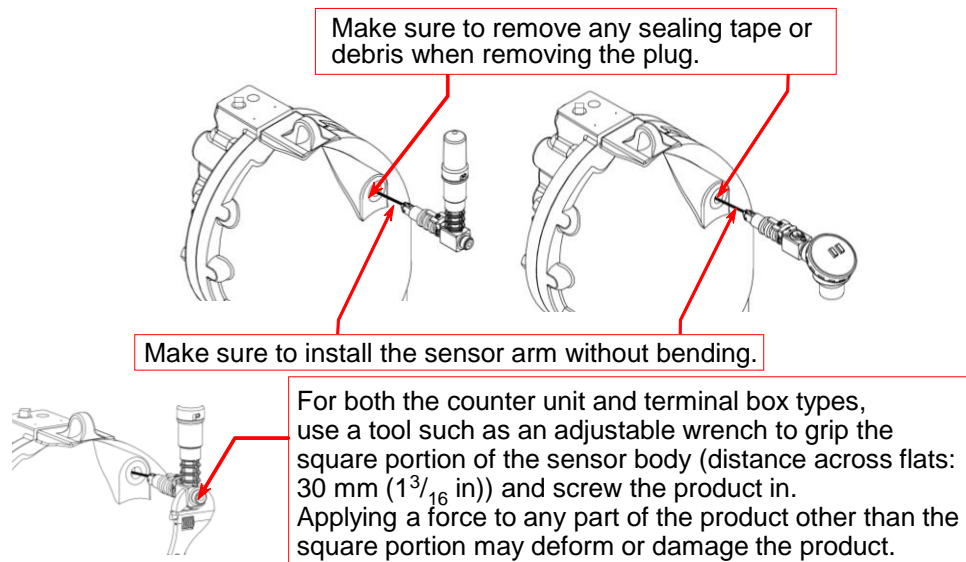

2. The following figure shows the product once installation is complete. Make sure to screw in the product with the body centered and facing upwards.

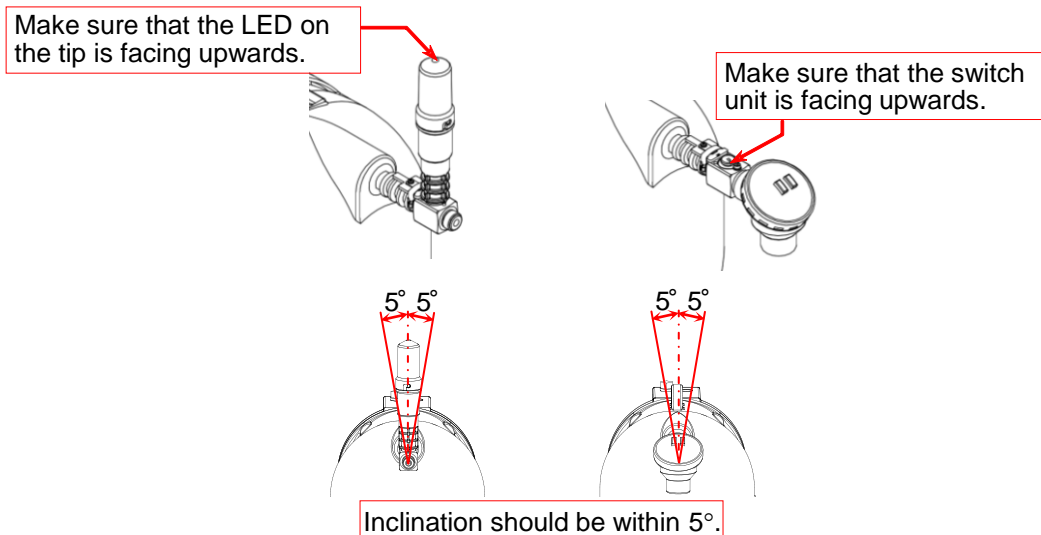

3. Before use, the wiring needs to be carried out for the terminal box type. Follow the figure shown below for the location of the wiring connections.

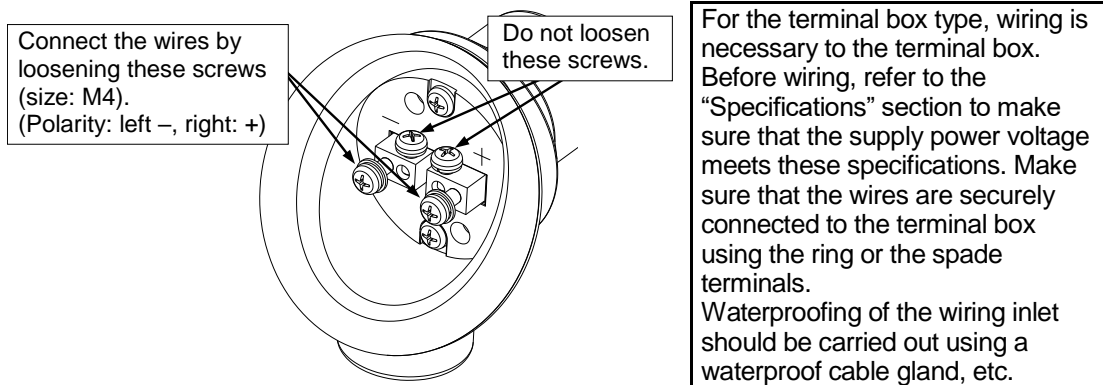

4. Make sure that the product is properly tightened before proceeding with the test operation.
For performing a test operation after the product has been installed, follow the procedure in the PowerTrap instruction manual.
Check motive medium supply piping and other piping connections before operation.
Operation should be carried out by trained personnel.
If the display needs to be reset on the counter unit after the test operation, refer to the "Resetting the counter on the LCD display of the counter unit" section described later in this manual.

Adjusting the angle of the LCD display on the counter unit

The angle of the LCD display on the counter unit can be changed.

NOTE	In order to prevent burns, make sure the product is removed from the PowerTrap before starting to work.
-------------	---

1. Remove the hex socket head bolt on the counter body.
Turn the cap counterclockwise, then pull up to remove it from the counter body.

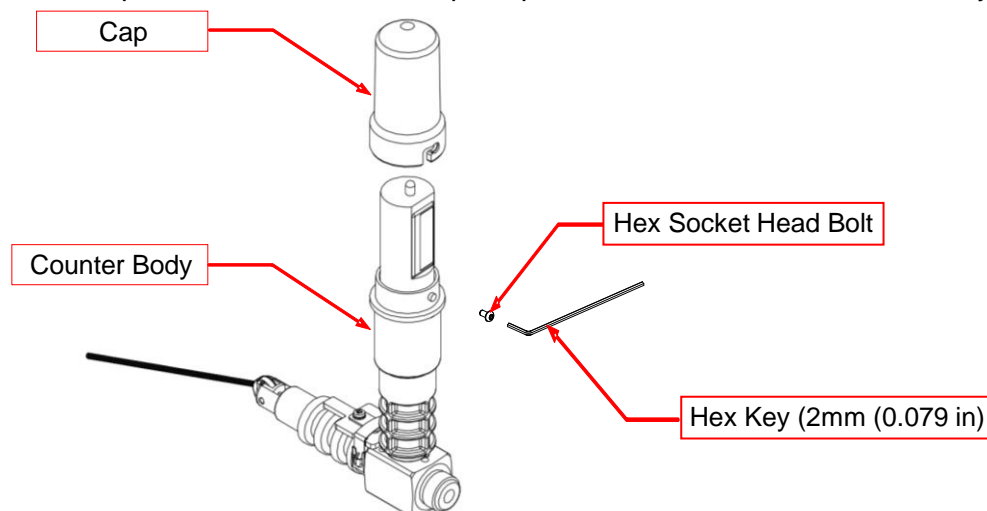

- Once the cap is removed, turn the silicon-molded LCD display so that the LCD display is readable. After the adjustment is made, put the transparent cap back on and retighten the hex socket head bolt (tightening torque: 0.5 N·m (0.4 lbf·ft)).

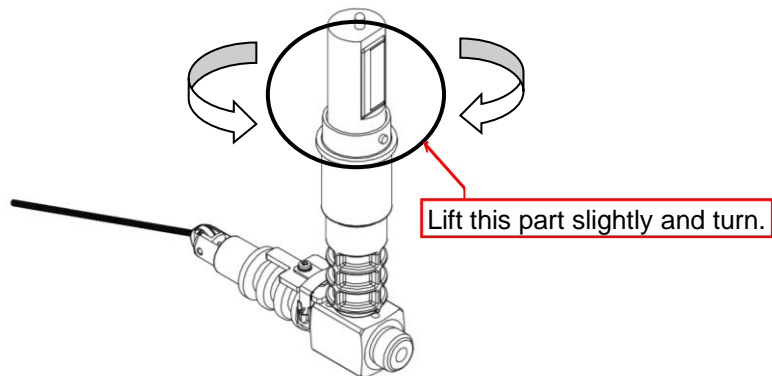

NOTE	Do not turn the LCD display part more than 360° to the left or right. Turning the display more than one rotation in either direction could cause disconnection of internal wiring or other malfunctions.
------	--

Resetting the counter on the LCD display of the counter unit

The numeric value displayed on the LCD of the counter unit can be reset.

NOTE	Once the counter is reset, the previous value is lost and cannot be recovered. In addition, failures of the PowerTrap caused by resetting the counter will not be covered under warranty.
------	---

Put the counter resetter close to the back of the LCD display as shown below. (The cap is removed in the figure below. The counter can be reset without removing the cap.) After the display clears momentarily, “0” will be displayed. Do not put the counter resetter close to the cycle counter other than for the purpose of resetting the counter display. Once the counter is reset to zero, it can not be returned to displaying the previous numeric value.

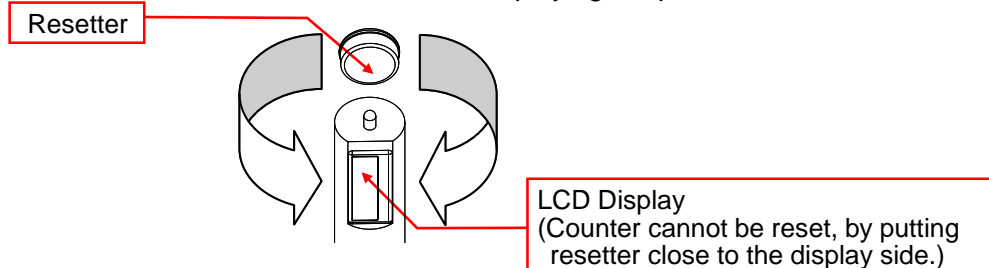

Magnet booster kit

If the cycle counter has been used in a high-temperature environment for a long period of time, the magnetic force of the reed switch becomes weaker, resulting in operational failure (the counter does not count).

For this reason, the magnet booster kit is installed on the upper part of the sensor body to prevent operational failure.

This booster kit has a built-in magnet to restore the magnetic force of the reed switch, preventing operational failure.

Contact TLV in the event if the magnet booster kit falls from the cycle counter.

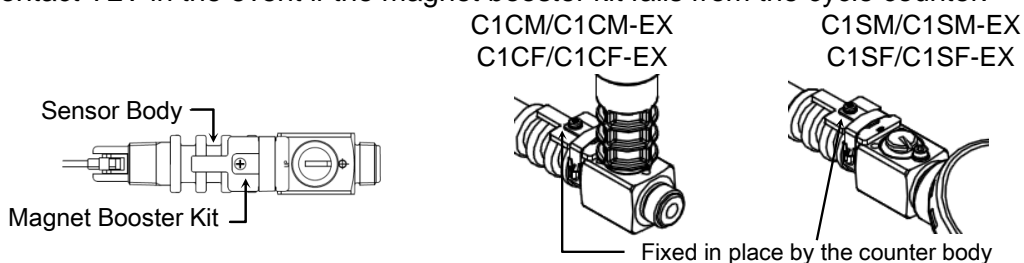

Troubleshooting



When disassembling or removing the product, wait until the internal pressure of the PowerTrap equals atmospheric pressure and the surface of the PowerTrap has cooled to room temperature. Disassembling or removing the product when it is hot or under pressure may lead to discharge of fluids, causing burns, other injuries or damage.



En cas de démontage ou de manipulation du produit, attendre que la pression interne du PowerTrap soit égale à la pression atmosphérique et que la surface du PowerTrap soit complètement refroidie. Le démontage ou la manipulation du produit lorsqu'il est chaud ou sous pression peut provoquer la fuite d'un fluide et entraîner des brûlures, des dommages ou autres blessures.

When the product fails to operate properly, use the following table to locate and remedy the cause.

	Problem	Cause	Remedy
Counter Unit Type	Nothing is displayed on the LCD display	Battery has been completely discharged	Replace with a new counter unit (The battery itself cannot be replaced)
	Cycle counter is not operating even though the PowerTrap is in operation (you can hear the snap action unit operating sound)	Sensitivity of the sensor is reduced	Adjust the sensitivity (See the "Adjusting the sensitivity for the counter unit type" section)
		Dirt or foreign matter has clogged the hinge part of the sensor arm, hindering its movement	Clean the moving area
Terminal Box Type	Cycle counter is not operating even though the PowerTrap is in operation (you can hear the snap action unit operating sound)	Sensitivity of the sensor is reduced	Adjust the sensitivity (See the "Adjusting the sensitivity for the terminal box type" section)
		Dirt or foreign matter has clogged the hinge part of the sensor arm, hindering its movement	Clean the moving area
	Improper wiring	Readjust the wiring	

If problems do not improve even after applying the remedies listed in "Troubleshooting", contact TLV.

Sensitivity adjustment for the counter unit type

When operating sounds can be heard from the PowerTrap however the cycle counter does not count or other symptoms appear, it is possible that the sensitivity of the sensor (the sensing accuracy of the reed switch) may have lowered due to aging of the product. In such cases, the sensitivity of the sensor can be restored by readjusting the distance between the magnet built in to the sensor body and the built-in reed switch in the counter body (or the switch unit for the terminal box type).

In this section, this is called sensitivity adjustment.

Make sure that the product is removed from the PowerTrap before you make sensitivity adjustment. Take precautions against burns, etc. when removing the unit.

1. Loosen the hex socket head bolt holding the counter body in place.
2. Then rotate the counter body as shown in the following figure on the next page while moving the sensor arm up and down. The counter body may be turned in either direction. Check the sensitivity by turning both ways (to the left and right). However do not turn more than 15° to the left or right.
3. Once the LED lights up in time with the movement of the sensor arm and has begun to count properly, the counter is considered to be operating normally.

- Secure the counter by re-tightening the hex socket head bolt (tightening torque: 1.5 N·m (1.1 lbf·ft)).

Loosen the hex socket head bolt and turn the counter body slightly to make sure that the counter is functioning properly.

Adjust the counter body by twisting within 15° to the left or right. The angle should be adjusted based on the matching mark on the body.

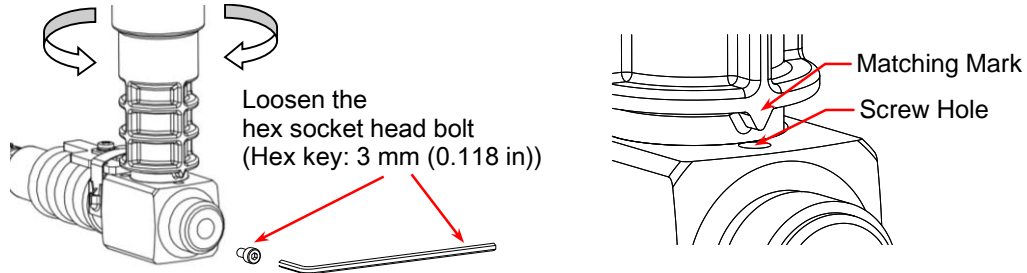

NOTE	DO NOT turn the body more than 15° to the left or right when adjusting the sensitivity.
------	---

NOTE	When removing/installing the hex socket head bolt, coat threaded portion with sealing agent to maintain waterproofing.
------	--

Sensitivity adjustment for the terminal box type

Make sure that the product is removed from the PowerTrap before you make sensitivity adjustment. Take precautions against burns, etc. when removing the unit. To adjust the sensitivity, you can use a circuit tester, or else rewiring will be necessary after removing the unit from the PowerTrap. In this section, we will describe the adjustment method using a circuit tester.

First, set the range of the circuit tester so that the resistance measurement can be carried out, then connect the leads to the plus and minus terminals on the terminal box (refer to the “Installation” section). Then move the sensor arm up and down and turn the switch unit little by little. The switch unit may be turned in either direction, however do not turn more than 15° to the left or right. When the resistance value of the circuit tester changes in time with the movement of the sensor arm, the unit is considered to be operating normally. After the adjustment is made, retighten the hex socket head bolt (tightening torque: 1.5 N·m (1.1 lbf·ft)).

Loosen the hex socket head bolt and turn the switch unit slightly with a coin, etc. to make sure that the counter is functioning properly.

Do not turn the switch unit more than 15° to the left or right. The position of the hex socket head bolt should be used to determine the angle.

Loosen the hex socket head bolt (Hex key: 3 mm (0.118 in))

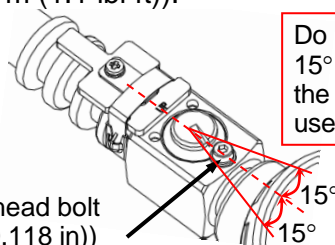

NOTE	DO NOT turn the body more than 15° to the left or right when adjusting the sensitivity.
------	---

Control Drawing

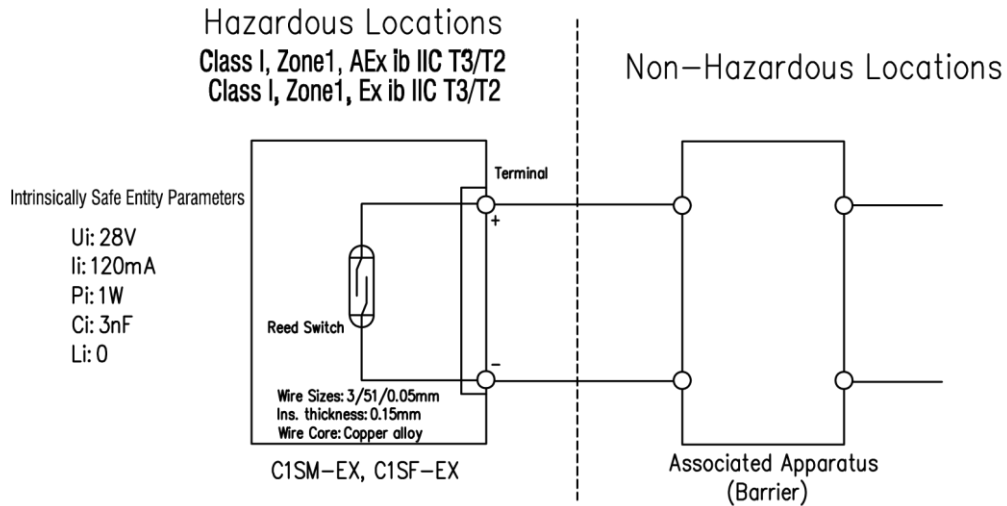

a. Associated apparatus output current must be limited by a resistor such that the output voltage-current plot is a straight line drawn between open-circuit voltage and short-circuit current.

b. Associated apparatus may be in a Division 2 or Zone 2 location if so approved.

c. Selected associated apparatus must be third party listed as providing intrinsically safe circuits for the application, and have U_o not exceeding U_i , I_o not exceeding I_i , and the P_o of the associated apparatus must be less than or equal to the P_i of the intrinsically safe equipment, as shown in Table 1.

I.S. Equipment		Associated Apparatus	
U_i	\geq	U_o	
I_i	\geq	I_o	
P_i	\geq	P_o	
$C_i + C_{Cable}$	\leq	C_o	
$L_i + L_{Cable}$	\leq	L_o	

d. Capacitance and inductance of the field wiring from the intrinsically safe equipment to the associated apparatus shall be calculated and must be included in the system calculations as shown in Table 1. Cable capacitance, C_{cable} , plus intrinsically safe equipment capacitance, C_i , must be less than the marked capacitance, C_o , shown on any associated apparatus used. The same applies for inductance (L_{cable} , L_i and L_o , respectively). Where the cable capacitance and inductance per foot are not known, the following values shall be used: $C_{cable} = 60 \text{ pF/ft.}$, $L_{cable} = 0.2 \text{ } \mu\text{H/ft.}$

e. Associated apparatus must be installed in accordance with its manufacturer's control drawing and Article 504 of the National Electrical Code (ANSI/NFPA 70) for installation in the United States, or Section 18 of the Canadian Electrical Code for installations in Canada.

f. When required by the manufacturer's control drawing, the associated apparatus must be connected to a suitable ground electrode per the National Electrical Code (ANSI/NFPA 70), the Canadian Electrical Code, or other local installation codes, as applicable. The resistance of the ground path must be less than 1 ohm.

g. Control equipment must not use or generate more than 250 V rms or dc with respect to earth.

UL-E535-B(02)

TLV EXPRESS LIMITED WARRANTY

Subject to the limitations set forth below, TLV Corporation, a North Carolina corporation (“**TLV**”) warrants that products which are sold by it, TLV CO., LTD., a Japanese corporation (“**TLVJ**”) or TLV International, Inc., a Japanese corporation (“**TII**”), (hereinafter the “**Products**”) are designed and manufactured by TLVJ, conform to the specifications published by TLV for the corresponding part numbers (the “**Specifications**”) and are free from defective workmanship and materials. With regard to products or components manufactured by unrelated third parties (the “**Components**”), TLV provides no warranty other than the warranty from the third party manufacturer(s), if any.

Exceptions to Warranty

This warranty does not cover defects or failures caused by:

1. improper shipping, installation, use, handling, etc., by other than TLV or service representatives authorized by TLV; or
2. dirt, scale or rust, etc.; or
3. improper disassembly and reassembly, or inadequate inspection and maintenance by other than TLV or service representatives authorized by TLV; or
4. disasters or forces of nature or Acts of God; or
5. abuse, abnormal use, accidents or any other cause beyond the control of TLV; or
6. improper storage, maintenance or repair; or
7. operation of the Products not in accordance with instructions issued with the Products or with accepted industry practices; or
8. use for a purpose or in a manner for which the Products were not intended; or
9. use of the Products in a manner inconsistent with the Specifications; or
10. use of the Products with Hazardous Fluids (fluids other than steam, air, water, nitrogen, carbon dioxide and inert gases (helium, neon, argon, krypton, xenon and radon)); or
11. failure to follow the instructions contained in the TLV Instruction Manual for the Product.

Duration of Warranty

This warranty is effective for a period of the earlier of: (i) three (3) years after delivery of Products to the first end user in the case of sealed SST-Series Products for use in steam pressure service up to 650 psig; (ii) two (2) years after delivery of Products to the first end user in the case of PowerTrap® units; or (iii) one (1) year after delivery of Products to the first end user in the case of all other Products. Notwithstanding the foregoing, asserting a claim under this warranty must be brought by the earlier of one of the foregoing periods, as applicable, or within five (5) years after the date of delivery to the initial buyer if not sold initially to the first end user.

ANY IMPLIED WARRANTIES NOT NEGATED HEREBY WHICH MAY ARISE BY OPERATION OF LAW, INCLUDING THE IMPLIED WARRANTIES OF MERCHANTABILITY AND FITNESS FOR A PARTICULAR PURPOSE AND ANY EXPRESS WARRANTIES NOT NEGATED HEREBY, ARE GIVEN SOLELY TO THE INITIAL BUYER AND ARE LIMITED IN DURATION TO ONE (1) YEAR FROM THE DATE OF SHIPMENT BY TLV.

Exclusive Remedy

THE EXCLUSIVE REMEDY UNDER THIS WARRANTY, UNDER ANY EXPRESS WARRANTY OR UNDER ANY IMPLIED WARRANTIES NOT NEGATED HEREBY (INCLUDING THE IMPLIED WARRANTIES OF MERCHANTABILITY AND FITNESS FOR A PARTICULAR PURPOSE), IS **REPLACEMENT**; PROVIDED: (a) THE CLAIMED DEFECT IS REPORTED TO TLV IN WRITING WITHIN THE APPLICABLE WARRANTY PERIOD, INCLUDING A DETAILED WRITTEN DESCRIPTION OF THE CLAIMED DEFECT AND HOW AND WHEN THE CLAIMED DEFECTIVE PRODUCT WAS USED; AND (b) THE CLAIMED DEFECTIVE PRODUCT AND A COPY OF THE PURCHASE INVOICE IS RETURNED TO TLV, FREIGHT AND TRANSPORTATION COSTS PREPAID, UNDER A RETURN MATERIAL AUTHORIZATION AND TRACKING NUMBER ISSUED

BY TLV. ALL LABOR COSTS, SHIPPING COSTS, AND TRANSPORTATION COSTS ASSOCIATED WITH THE RETURN OR REPLACEMENT OF THE CLAIMED DEFECTIVE PRODUCT ARE SOLELY THE RESPONSIBILITY OF BUYER OR THE FIRST END USER. TLV RESERVES THE RIGHT TO INSPECT ON THE FIRST END USER'S SITE ANY PRODUCTS CLAIMED TO BE DEFECTIVE BEFORE ISSUING A RETURN MATERIAL AUTHORIZATION. SHOULD SUCH INSPECTION REVEAL, IN TLV'S REASONABLE DISCRETION, THAT THE CLAIMED DEFECT IS NOT COVERED BY THIS WARRANTY, THE PARTY ASSERTING THIS WARRANTY SHALL PAY TLV FOR THE TIME AND EXPENSES RELATED TO SUCH ON-SITE INSPECTION.

Exclusion of Consequential and Incidental Damages

IT IS SPECIFICALLY ACKNOWLEDGED THAT THIS WARRANTY, ANY OTHER EXPRESS WARRANTY NOT NEGATED HEREBY, AND ANY IMPLIED WARRANTY NOT NEGATED HEREBY, INCLUDING THE IMPLIED WARRANTIES OF MERCHANTABILITY AND FITNESS FOR A PARTICULAR PURPOSE, DO NOT COVER, AND NEITHER TLV, TII NOR TLVJ WILL IN ANY EVENT BE LIABLE FOR, INCIDENTAL OR CONSEQUENTIAL DAMAGES, INCLUDING, BUT NOT LIMITED TO LOST PROFITS, THE COST OF DISASSEMBLY AND SHIPMENT OF THE DEFECTIVE PRODUCT, INJURY TO OTHER PROPERTY, DAMAGE TO BUYER'S OR THE FIRST END USER'S PRODUCT, DAMAGE TO BUYER'S OR THE FIRST END USER'S PROCESSES, LOSS OF USE, OR OTHER COMMERCIAL LOSSES. WHERE, DUE TO OPERATION OF LAW, CONSEQUENTIAL AND INCIDENTAL DAMAGES UNDER THIS WARRANTY, UNDER ANY OTHER EXPRESS WARRANTY NOT NEGATED HEREBY OR UNDER ANY IMPLIED WARRANTY NOT NEGATED HEREBY (INCLUDING THE IMPLIED WARRANTIES OF MERCHANTABILITY AND FITNESS FOR A PARTICULAR PURPOSE) CANNOT BE EXCLUDED, SUCH DAMAGES ARE EXPRESSLY LIMITED IN AMOUNT TO THE PURCHASE PRICE OF THE DEFECTIVE PRODUCT. THIS EXCLUSION OF CONSEQUENTIAL AND INCIDENTAL DAMAGES, AND THE PROVISION OF THIS WARRANTY LIMITING REMEDIES HEREUNDER TO REPLACEMENT, ARE INDEPENDENT PROVISIONS, AND ANY DETERMINATION THAT THE LIMITATION OF REMEDIES FAILS OF ITS ESSENTIAL PURPOSE OR ANY OTHER DETERMINATION THAT EITHER OF THE ABOVE REMEDIES IS UNENFORCEABLE, SHALL NOT BE CONSTRUED TO MAKE THE OTHER PROVISIONS UNENFORCEABLE.

Exclusion of Other Warranties

THIS WARRANTY IS IN LIEU OF ALL OTHER WARRANTIES, EXPRESS OR IMPLIED, AND ALL OTHER WARRANTIES, INCLUDING BUT NOT LIMITED TO THE IMPLIED WARRANTIES OF MERCHANTABILITY AND FITNESS FOR A PARTICULAR PURPOSE, ARE EXPRESSLY DISCLAIMED.

Severability

Any provision of this warranty which is invalid, prohibited or unenforceable in any jurisdiction shall, as to such jurisdiction, be ineffective to the extent of such invalidity, prohibition or unenforceability without invalidating the remaining provisions hereof, and any such invalidity, prohibition or unenforceability in any such jurisdiction shall not invalidate or render unenforceable such provision in any other jurisdiction.

TLV CORPORATION

13901 South Lakes Drive, Charlotte, NC 28273-6790, U.S.A.
Tel: [1]-704-597-9070 Fax: [1]-704-583-1610