



COSPECT[®]

STEAM PRESSURE REDUCING VALVE

MODEL COS-21

SELF-ACTUATED STEAM CONDITIONING SYSTEM WITH UNIQUE PISTON DESIGN

Benefits

Technologically advanced COSPECT Pressure Reducing Valve provides accurate control and steam conditioning to maximize process steam system performance.

1. Combination conditioning system includes pressure reducing valve, condensate separator, and steam trap.
2. Unique SCE separator's 98% efficiency can deliver high quality steam of 99.8% dryness.
3. Resulting dry steam improves heat transfer by 9% average, enhances product quality, speeds batch times, and extends down-stream valve life.
4. Unique Shock-Absorbing Spherical (SAS) piston delivers stable secondary pressure.
5. Valve maintains high accuracy during severe conditions of varying primary pressure and fluctuating flow rates.
6. Internal screens for pilot and main valves extend maintenance-free service.
7. Designed with PTFE gaskets for inspection ease.

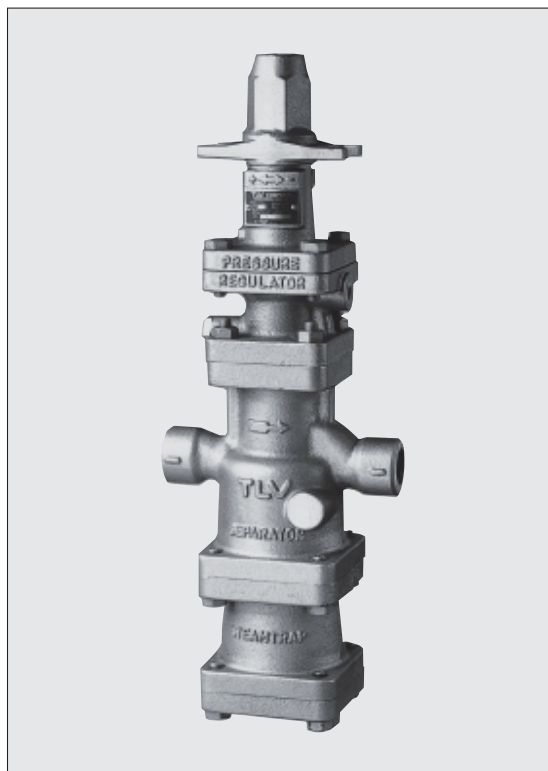

Specifications

Model		COS-21
Connection		Screwed
Size (in)		1/2, 3/4, 1
Body Material		Ductile Cast Iron
Maximum Operating Pressure (psig)	PMO	300
Maximum Operating Temperature (°F)	TMO	428
Maximum Allowable Pressure (psig)	PMA	300
Maximum Allowable Temperature (°F)	TMA	428
Primary Pressure Range (psig)		190 to 300
Adjustable Differential Pressure (psig)		30 to 120
Pressure Adjustment Range (psig)		80 to 252
Maximum Adjustable Secondary Pressure (psig)		84% of Primary Pressure
Minimum Adjustable Secondary Pressure (psig)		80 psig (or Primary Pressure minus 120 psi, whichever is higher)
Minimum Adjustable Flow Rate		5% of Rated Flow Rate
Accuracy of Regulation (psi)	AOR	± 1 (under steady flow conditions)
Seat Leakage Rating		Less than 0.1% of Rated Flow Rate

COS-21 is a non-standard product; consult TLV for delivery time required.



To avoid abnormal operation, accidents or serious injury, DO NOT use this product outside of the specification range. Local regulations may restrict the use of this product to below the conditions quoted.

Configuration

No.	Description	Material
①	Main Body	Ductile Cast Iron
②	Trap Body	Ductile Cast Iron
③	Trap Cover	Ductile Cast Iron
④	Separator	Stainless Steel
⑤	Float	Stainless Steel
⑥	Float Cover	Cast Iron
⑦	Trap Valve Seat	Stainless Steel
⑧	Separator Screen	Stainless Steel
⑨	Main Valve Seat	Stainless Steel
⑩	Main Valve	Stainless Steel
⑪	Main Valve Holder	Stainless Steel
⑫	Piston	Stainless Steel
⑬	Cylinder	Stainless Steel
⑭	Pilot Screen	Stainless Steel
⑮	Pilot Screen Holder	Carbon Steel
⑯	Pilot Valve Body	Ductile Cast Iron
⑰	Pilot Valve	Stainless Steel
⑱	Pilot Valve Seat	Stainless Steel
⑲	Diaphragm	Stainless Steel
⑳	Diaphragm Support	Brass
㉑	Spring Housing	Ductile Cast Iron
㉒	Coil Spring	Carbon Steel
㉓	Adjustment Screw	Cr-Mo Steel
㉔	Spanner Cap	Die Cast Aluminium
㉕	Nameplate	Stainless Steel

Contact TLV for available replacement parts. All gaskets are PTFE.

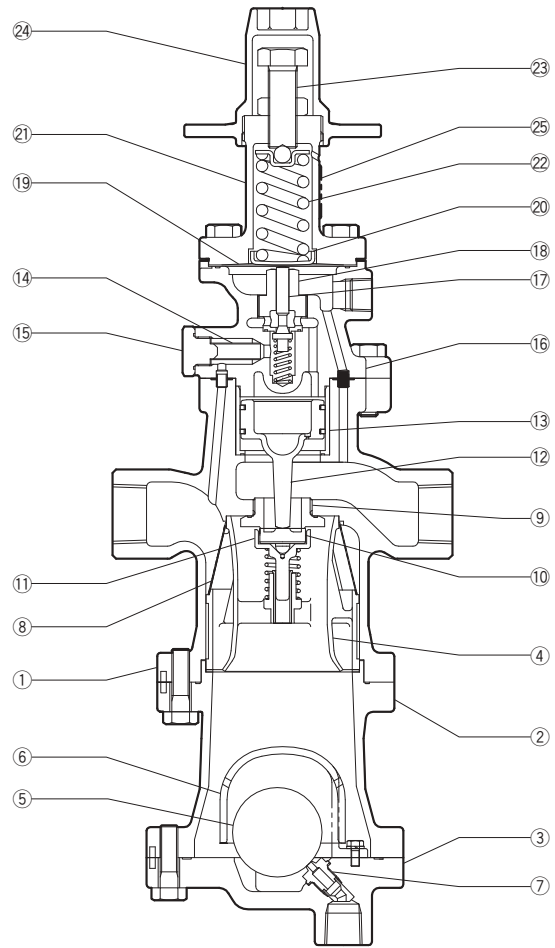

Cv Values

	Nominal Valve Size		
	1/2"	3/4"	1"
Cv (US)	3.8	6.9	11.1
Cv (UK)	3.2	5.7	9.2
Kvs (DIN)	3.3	5.9	9.5

CAUTION The Cv values shown are for the valve in the full fail open position. These values are not to be used for COS sizing, and instead may be used as one of the factors in calculations for safety valve selection.

Capacity Table

With external (factory standard) or internal (option) secondary pressure-sensing line or channel (lb/h)

Primary Steam Press. (psig)	Secondary (Set) Steam Pressure (psig)		Nominal Valve Size		
	External Line	Internal Channel (option)	½"	¾"	1"
190	* 160	* 160	610	940	1360
	150	150	800	1120	1640
	125	125	940	1330	1880
	100	100	1100	1620	2220
	** 80 - 95	95	1100	1640	2250
		** 80	890	1310	1940
200	* 168	* 168	640	940	1370
	160	160	720	1060	1520
	150	150	880	1300	1830
	125	125	1040	1530	2240
	** 80 - 100	100	1300	1850	2870
		** 80	970	1370	1920
210	* 176	* 176	720	1030	1500
	175	175	730	1040	1520
	150	150	1050	1540	2190
	125	125	1190	1730	2530
	** 90 - 105	105	1310	1860	2830
		100	1270	1810	2760
		** 90	1130	1640	2430
225	* 189	* 189	740	1050	1530
	185	185	790	1130	1620
	175	175	900	1300	1820
	150	150	1260	1810	2760
	125	125	1420	2010	3030
	** 105 - 113	113	1500	2080	3270
		** 105	1390	1970	3010
240	* 202	* 202	820	1150	1650
	200	200	840	1180	1700
	175	175	1140	1650	2390
	150	150	1550	2290	3420
	125	125	1680	2480	3800
	** 120	** 120	1700	2480	3870
250	* 210	* 210	880	1260	1770
	200	200	990	1450	2030
	175	175	1290	1900	2780
	150	150	1720	2590	3960
	** 130	** 130	1810	2790	4340
260	* 218	* 218	970	1410	1960
	210	210	1040	1550	2120
	200	200	1160	1710	2440
	175	175	1520	2200	3340
	150	150	1950	3060	4790
	** 140	** 140	2010	3170	5020
275	* 231	* 231	990	1420	2000
	225	225	1060	1520	2170
	200	200	1390	1980	3020
	175	175	1740	2650	4100
	** 155	** 155	1990	3200	4970
290	* 244	* 244	980	1430	1950
	240	240	1050	1510	2130
	225	225	1280	1810	2750
	200	200	1660	2410	3770
	175	175	1930	3100	4940
	** 170	** 170	1990	3280	5120
300	* 252	* 252	920	1400	1780
	250	250	1040	1540	2090
	225	225	1460	2090	3300
	200	200	1850	2980	4410
	** 180	** 180	2060	3460	5380

* Maximum adjustable secondary pressure ** Minimum adjustable secondary pressure

Dimensions

• **COS-21** Screwed*

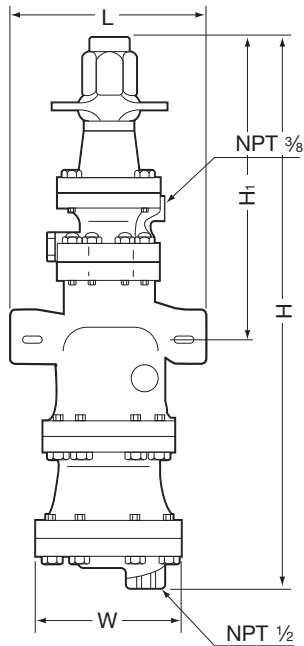

COS-21 Screwed* (in)

Size	L	H	H ₁	W	Weight (lb)
1/2	6 7/8	20 1/4	12	4 1/8	33
3/4					35
1	7 1/2	21 5/16	11 7/8	5 7/8	44

* NPT, other standards available

Discharge Capacity of Steam Trap

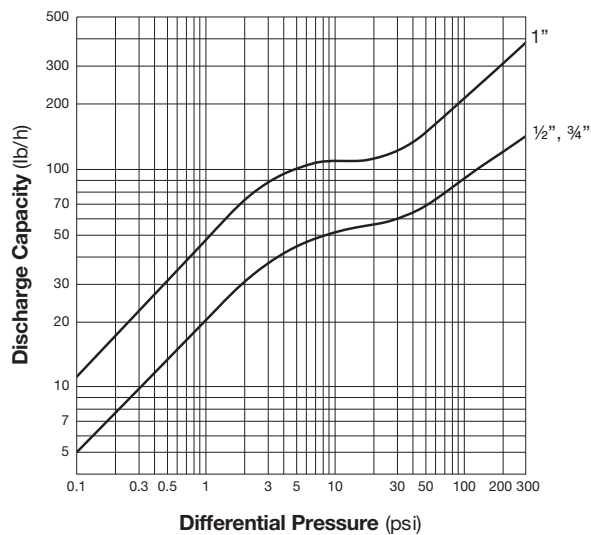

- Note: 1. The discharge capacity is the maximum continuous condensate discharge 11 °F below saturated steam temperature.
 2. The differential pressure is the difference between the COS-21 inlet and its trap outlet pressure.

CAUTION DO NOT use this product under conditions that exceed maximum differential pressure, as condensate backup will occur!

Option

Pressure Gauge Unit	Replaces the standard screen holder plug to enable installation of a pressure gauge of the user's choice. Primary side: M16 holder plug (male/female), BSP/Rc(PT)/NPT 3/8. An elbow is required for pressure gauge installation. Secondary side: Rc(PT) 3/8 mounting port for elbow and pressure gauge installation.
	Elbows, pressure gauge and connecting parts must be purchased separately.

● **Configuration**

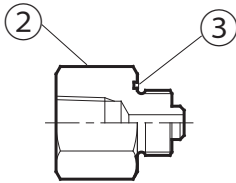

● **Installation Example**

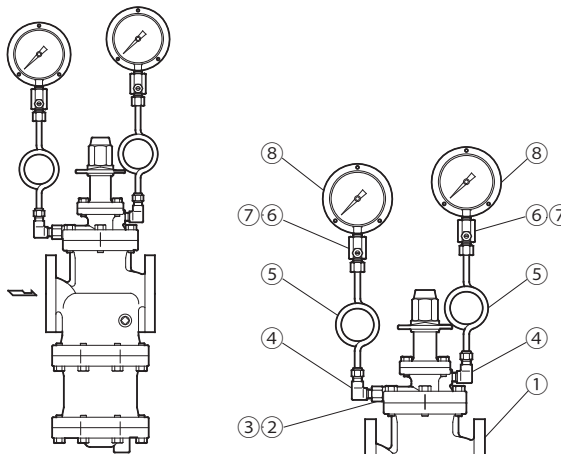

NOTE: For explanation purposes, a siphon tube style pressure gauge will be used. However, the instructions also apply to cooling tower-style pressure gauges.

No.	Part Name	No.	Part Name
1	Valve Body	5	Siphon Tube*
2	Holder Plug	6	Dampener*
3	Holder Plug Gasket	7	Dampener Gasket*
4	Elbow (male/female)*	8	Pressure Gauge*

* Purchase separately



DO NOT DISASSEMBLE OR REMOVE THIS PRODUCT WHILE IT IS UNDER PRESSURE.
Allow internal pressure of this product to equal atmospheric pressure and its surface to cool to room temperature before disassembling or removing. Failure to do so could cause burns or other injury. READ INSTRUCTION MANUAL CAREFULLY.

TLV CORPORATION

13901 South Lakes Drive, Charlotte, NC 28273-6790
Tel: 704-597-9070 Fax: 704-583-1610
E-mail: tlv@tlvengineering.com <https://www.tlv.com>
For Technical Service 1-800 "TLV TRAP"



Manufacturer
TLV CO., LTD.
Kakogawa, Japan
is approved by LRQA Ltd. to ISO 9001/14001

ISO 9001
ISO 14001

