



# CYCLONE SEPARATOR

## MODEL DC7

### HIGH EFFICIENCY STAINLESS STEEL SEPARATOR

#### Benefits

All stainless steel separator, employing the Super Cyclone-Effect to efficiently separate condensate from steam, air and inert gases.

1. Unique SCE separator's efficiency can deliver high-quality steam up to 99.8% dryness.
2. All-welded, maintenance-free construction.
3. Compact and light weight.
4. All parts made from stainless steel with high durability and corrosion resistance for long service life.



#### Specifications

Model		DC7	
Connection		Screwed	Flanged
Size (in)		<b>1/2, 3/4, 1, 1 1/2, 2</b>	<b>1 1/2, 2</b>
Maximum Operating Pressure (psig)	PMO	362	
Maximum Operating Temperature (°F)	TMO	572	
Maximum Allowable Pressure (psig)	PMA	362	
Maximum Allowable Temperature (°F)	TMA	572	
Applicable Fluids*		Steam, Air, Inert Gas	

\* Do not use for toxic, flammable or otherwise hazardous gases.

**Connections and sizes in bold are standard**



To avoid abnormal operation, accidents or serious injury, DO NOT use this product outside of the specification range. Local regulations may restrict the use of this product to below the conditions quoted.

No.	Description	Material	ASTM/AISI*	JIS
①	Body	Cast Stainless Steel	A351 Gr.CF8	—
②	Separator	Cast Stainless Steel	A351 Gr.CF8	—
③	Separator Body	Stainless Steel	AISI304	SUS304
④	Separator Bottom	Cast Stainless Steel	A351 Gr.CF8	—
⑤	Baffle	Stainless Steel	AISI304	SUS304
⑥	Flange**	Stainless Steel/ Cast Stainless Steel	AISI304/ A351 Gr.CF8	SUS304/ —
⑦	Nameplate	Stainless Steel	AISI304	SUS304

\* Equivalent \*\* Material depends on flange specifications

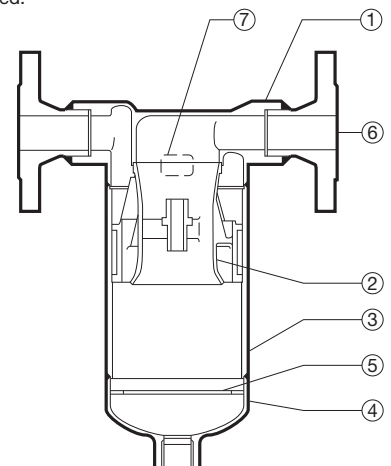

### Flow Rate (Steam)

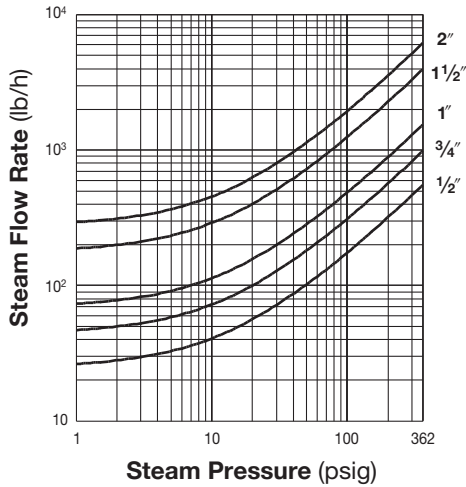

The chart above is used to determine the steam flow rate through the DC7 separator. It is based on a steam velocity of 100 ft/s. For other velocities, calculate the flow rate as follows:

$$\text{Flow Rate (at } v \text{ ft/s)} = \text{Flow Rate (at 100 ft/s)} \times \frac{v}{100}$$

It is recommended that velocities not exceed 100 ft/s.

### Pressure Loss (Steam)

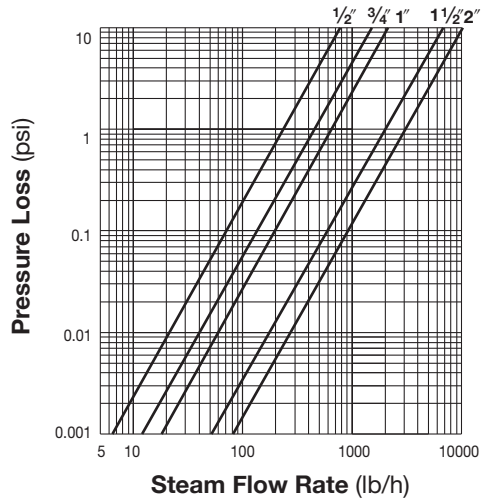

The pressure loss chart is based on a steam pressure of 150 psig. For other pressures, multiply the steam flow rate by the correction factor given in the table below. Use the result on the pressure loss chart.

Pressure (psig)	10	50	100	150	200	300	362
Flow Rate Correction Factor	2.32	1.54	1.16	1.00	0.90	0.72	0.67

### Flow Rate (Air)

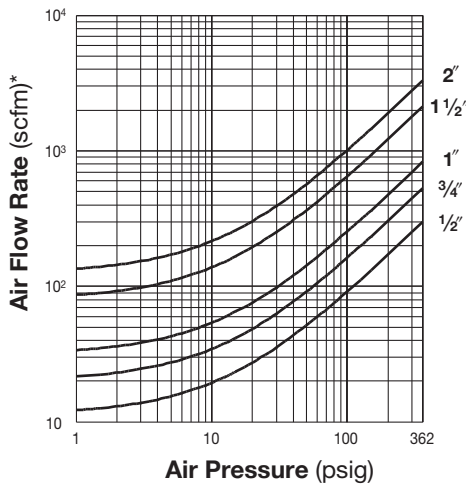

The chart above is used to determine the air flow rate through the DC7 separator. It is based on an air velocity of 100 ft/s. For other velocities, calculate the flow rate as follows:

$$\text{Flow Rate (at } v \text{ ft/s)} = \text{Flow Rate (at 100 ft/s)} \times \frac{v}{100}$$

### Pressure Loss (Air)

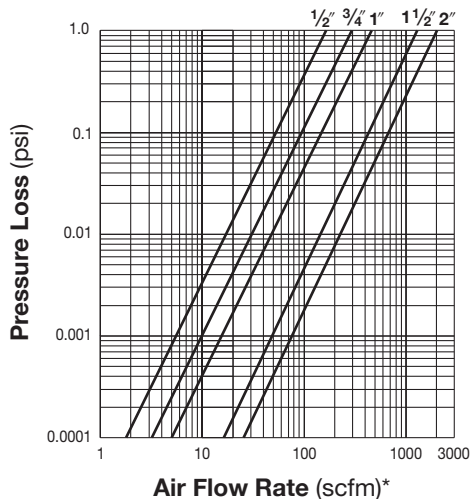

The pressure loss chart is based on an air pressure of 150 psig. For other pressures, multiply the air flow rate by the correction factor given in the table below. Use the result on the pressure loss chart.

Pressure (psig)	10	50	100	150	200	300	362
Flow Rate Correction Factor	6.78	2.56	1.44	1.00	0.80	0.52	0.44

\* Air flow rates are equivalent flow rates of air at 68 °F under atmospheric pressure.

## Dimensions

• **DC7** Screwed

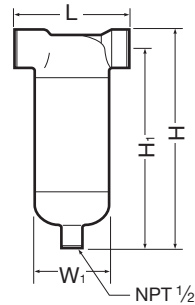

**DC7** Screwed\* (in)

Size	L	H	H <sub>1</sub>	φW <sub>1</sub>	Weight (lb)
1/2	5 1/8	9	8 1/4	3 1/2	7.5
3/4					
1	5 7/8	10 3/8	9 7/16	4	12
1 1/2	6 11/16	12 13/16	11 5/8	4 1/2	14
2	8 1/16	15 5/8	14 3/16	6 1/2	33

\* NPT, other standards available

• **DC7** Flanged

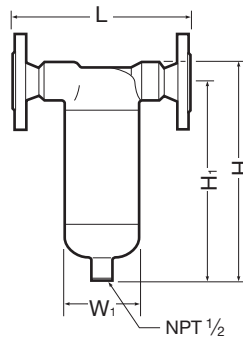

**DC7** Flanged (in)

Size	L		H	H <sub>1</sub>	φW <sub>1</sub>	Weight* (lb)
	Connects to ASME Class					
	150RF	<b>300RF</b>				
1 1/2	9 7/8	10 3/16	12 13/16	11 5/8	4 1/2	27
2	13	13 1/4	15 5/8	14 3/16	6 1/2	49

Other standards available, but length and weight may vary

\* Weight is for Class 300RF

**Flange classes in bold are standard**

## Separation Efficiency

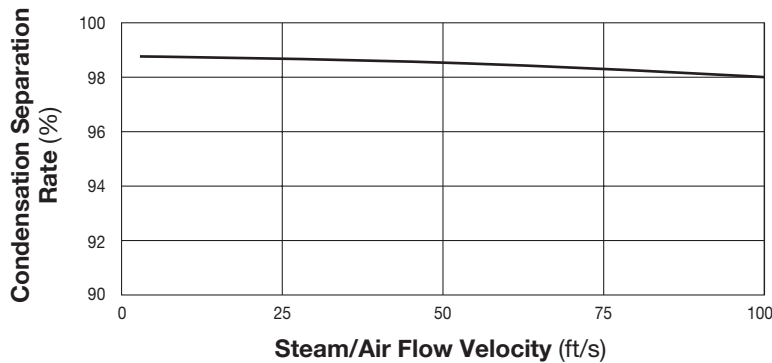

Accuracy: ± 2%

Condensation: 90 – 110 lb/h

$$\text{Separation rate (\%)} = \frac{\text{Quantity of condensate discharged}}{\text{Quantity of incoming condensate}} \times 100\%$$

Note: It is recommended that steam flow velocities not exceed 100 ft/s

**Quality of Exiting Vapor Stream:**

Example: 1000 lb/hr mass flow with a dryness fraction of 0.90 (i.e., 900 lb/hr vapor, 100 lb/hr water) enters the separator.

With an efficiency of 98%, 98 lb/h of water is separated from the stream (100 lb/h × 0.98 = 98 lb/h).

Outlet side total mass flow will be 902 lb/h (i.e., 900 lb/h vapor, 2 lb/h water (100 lb/h - 98 lb/h)).

$$\text{Resulting dryness fraction} = \frac{\text{Vapor mass flow}}{\text{Total mass flow}} = \frac{900 \text{ lb/h}}{902 \text{ lb/h}} = 0.9978$$

Note: Does not apply to the separation of fine entrained mist. Contact TLV for details concerning mist elimination procedures.

## Steam Trap Selection

The DC7 separator does not have a built-in steam trap. A trap will need to be installed for the proper removal of condensate from the system. Choose an appropriate trap for the application from the table below.

Steam Pressure	Low (up to 250 psig)	High (up to 362 psig)
DC7 Size	Suitable Steam Traps	Suitable Steam Traps
1/2"	FS3, SS1, SS3	FS5, SS5
3/4"	FS3, SS1, SS3	FS5, SS5
1"	FS3, SS1, SS3	FS5, SS5
1 1/2"	FS5, SS5	FS5, SS5
2"	FS5, SS5	FS5, SS5

### Steam Trap Installation (Vertical & Horizontal)

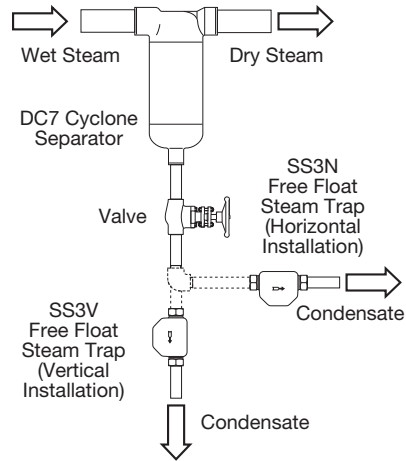

## Air Trap Selection

The DC7 separator does not have a built-in air trap. A trap will need to be installed for the proper removal of condensate from the system. Choose an appropriate trap for the application from the table at right.

Air Pressure	Low (up to 300 psig)	High (up to 362 psig)
DC7 Size	Suitable Air Trap	Suitable Air Trap
1/2" - 2"	SS1VA	JAH5RA*

\* JAH5RA series is cast steel, stainless steel version available on special order  
Optional JAH5RA-M (with metal orifice) is required for given pressure

### Air Trap Installation (Vertical)

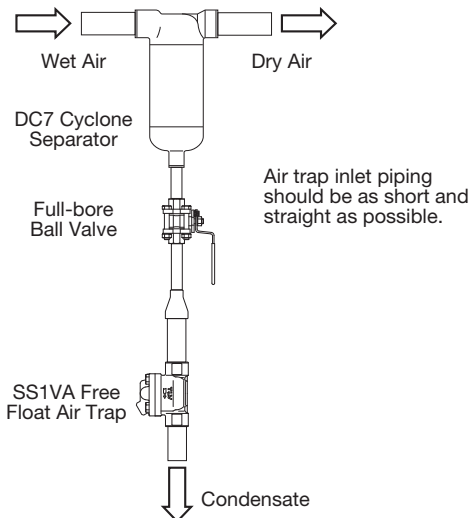

### Air Trap Installation (Horizontal)

When the horizontal installation of an air trap is required, a pressure-balancing line must be connected from the balancing port on the air trap to a place above any possible condensate accumulation.

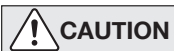
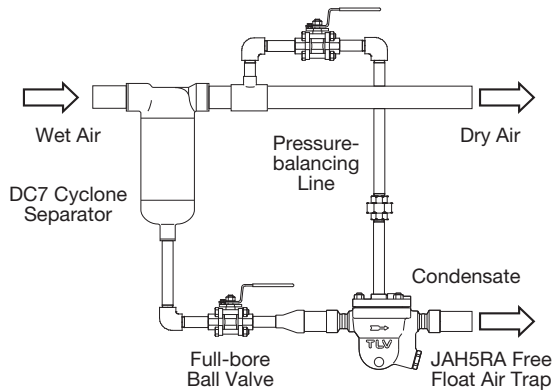

**DO NOT DISASSEMBLE OR REMOVE THIS PRODUCT WHILE IT IS UNDER PRESSURE.**  
Allow internal pressure of this product to equal atmospheric pressure and its surface to cool to room temperature before disassembling or removing. Failure to do so could cause burns or other injury. READ INSTRUCTION MANUAL CAREFULLY.

## TLV CORPORATION

13901 South Lakes Drive, Charlotte, NC 28273-6790  
Tel: 704-597-9070 Fax: 704-583-1610  
E-mail: [tlv@tlvengineering.com](mailto:tlv@tlvengineering.com) <https://www.tlv.com>  
For Technical Service 1-800 "TLV TRAP"



Manufacturer  
**TLV CO., LTD.**  
Kakogawa, Japan  
is approved by LRQA Ltd. to ISO 9001/14001

