



# FREE FLOAT<sup>®</sup> AIR TRAP

## MODEL JA7.2

### HIGH-CAPACITY FREE FLOAT COMPRESSED AIR TRAP

#### Benefits

**Extremely durable, inline-repairable free float trap with a large capacity for automatic drainage of condensate and oil from compressed-air systems. Recommended installations include large receiver tanks and after coolers.**

1. Self-modulating free float provides continuous, smooth, low velocity condensate discharge as process loads vary, for maximum performance.
2. Unique rotational seating design prevents concentrated wear to provide long maintenance-free service life.
3. Rugged float construction with up to 1500 psig hydraulic shock rating ensures excellent performance of the trap.
4. Easy, inline access to internal parts simplifies cleaning and lowers maintenance costs.
5. Built-in screen with large surface area ensures extended trouble-free service.
6. The valve seat is made of PTFE and other major internal parts are made of stainless steel.



#### Specifications

Model		JA7.2
Connection		Flanged
Size (in)		1 1/2, 2, 3
Orifice No.		2, 5, 10, 16
Maximum Operating Pressure (psig)	PMO	30, 75, 150, 230
Maximum Differential Pressure (psi)	ΔPMX	30, 75, 150, 230
Minimum Operating Pressure (psig)		Vacuum
Maximum Operating Temperature (°F)	TMO	302
Maximum Allowable Pressure (psig)	PMA	230
Maximum Allowable Temperature (°F)	TMA	428
Minimum Condensate Load for Tight Sealing (lb/h)		22
Applicable Fluid*		Air

\* Do not use for toxic, flammable or otherwise hazardous fluids.

JA7.2 is a non-standard product, consult TLV for delivery time required.



To avoid abnormal operation, accidents or serious injury, DO NOT use this product outside of the specification range. Local regulations may restrict the use of this product to below the conditions quoted.

No.	Description	Material	ASTM/AISI*	JIS
①	Body	Cast Iron	A842 Gr.400	FCV400
②	Cover	Cast Iron	A842 Gr.400	FCV400
③ <sup>F</sup>	Float	Stainless Steel	AISI316L	SUS316L
④ <sup>R</sup>	Valve Seat Holder	Stainless Steel	AISI420F	SUS420F
⑤ <sup>MR</sup>	Valve Seat Holder O-Ring	Fluorine Rubber	D2000HK	FPM
⑥ <sup>R</sup>	Valve Seat (Orifice)	Fluorine Resin	PTFE	PTFE
⑦ <sup>R</sup>	Snap Ring	Stainless Steel	AISI304	SUS304
⑧ <sup>MR</sup>	Valve Seat O-Ring	Fluorine Rubber	D2000HK	FPM
⑨	Valve Seat Holder Plug	Cast Iron	A842 Gr.400	FCV400
⑩ <sup>MR</sup>	Holder Plug Gasket	Fluorine Resin	PTFE	PTFE
⑪ <sup>R</sup>	Screen	Stainless Steel	AISI430	SUS430
⑫	Screen Holder	Stainless Steel	AISI304	SUS304
⑬ <sup>MR</sup>	Cover Gasket	Fluorine Resin	PTFE	PTFE
⑭	Cover Bolt	Carbon Steel	AISI1045	S45C
⑮	Balancing Line Plug	Carbon Steel	AISI1010	S10C
⑯	Alignment Pin	Steel	A485	SUJ2
⑰	Nameplate	Stainless Steel	AISI304	SUS304
⑱	Drain Plug	Carbon Steel	A307 Gr.B	SS400

\* Equivalent

Replacement kits available: (M) maintenance parts, (R) repair parts, (F) float

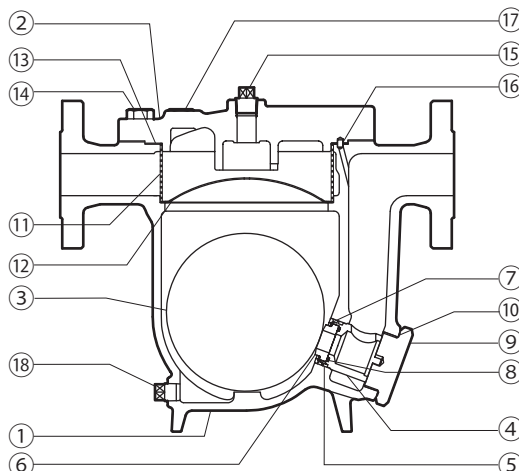

**Dimensions**

• **JA7.2** Flanged

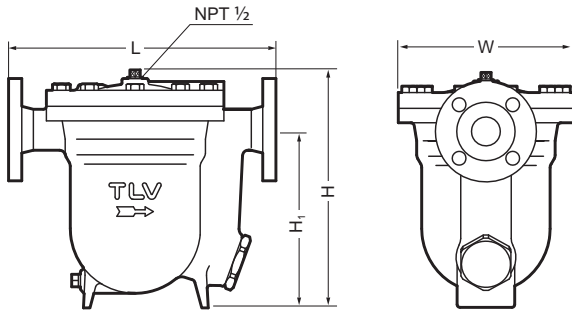

**JA7.2** Flanged (in)

Size	L		H	H <sub>1</sub>	φ W	Weight* (lb)
	Connects to ASME Class					
	125FF	250RF				
1 1/2	14 1/8	14 5/8	13	9 5/8	9 9/16	73
2	14 1/4	14 3/4	13 3/8	9 7/8		79
3	14 15/16	15 1/16	14 5/8	10 7/16		90

Other standards available, but length and weight may vary  
\* Weight is for Class 250 RF.

**NOTE:**

A pressure-balancing line must be connected to the air system from the balancing port at the top of the trap to a place above any possible condensate accumulation in the system.

**Discharge Capacity**

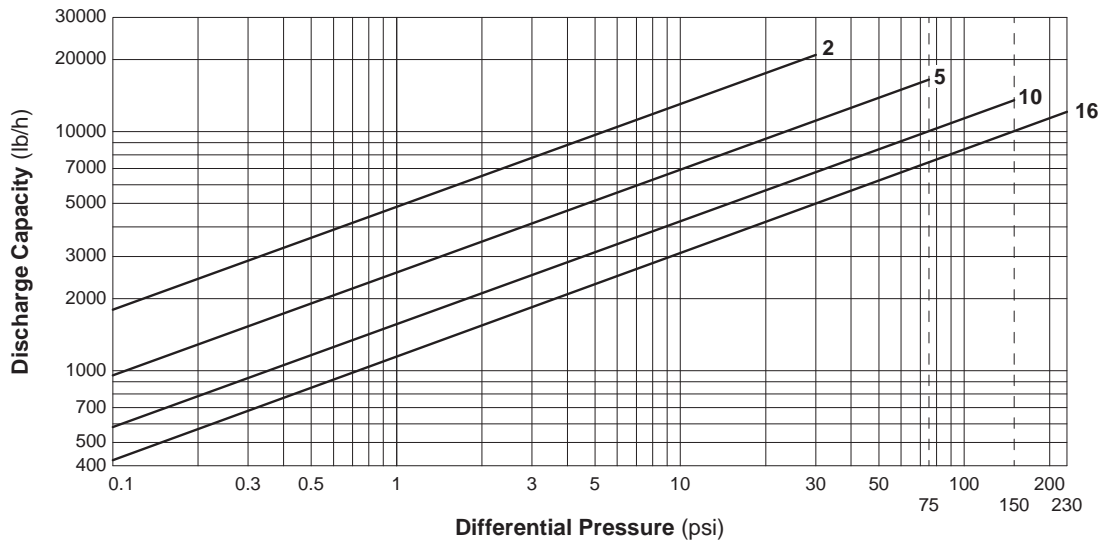

1. Line numbers within the graph refer to orifice numbers.
2. Differential pressure is the difference between the inlet and outlet pressure of the trap.
3. The chart is applicable to condensate below 212 °F
4. The discharge capacity is for a liquid with specific gravity of 1.
5. Recommended safety factor: at least 1.5

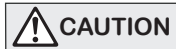

**CAUTION** DO NOT use this product under conditions that exceed maximum differential pressure, as condensate backup will occur!



**CAUTION** DO NOT DISASSEMBLE OR REMOVE THIS PRODUCT WHILE IT IS UNDER PRESSURE. Allow internal pressure of this product to equal atmospheric pressure and its surface to cool to room temperature before disassembling or removing. Failure to do so could cause burns or other injury. READ INSTRUCTION MANUAL CAREFULLY.

**TLV CORPORATION**

13901 South Lakes Drive, Charlotte, NC 28273-6790  
Tel: 704-597-9070 Fax: 704-583-1610  
E-mail: [tlv@tlvengineering.com](mailto:tlv@tlvengineering.com) <https://www.tlv.com>  
For Technical Service 1-800 "TLV TRAP"



Manufacturer  
**TLV CO., LTD.**  
Kakogawa, Japan  
is approved by LRQA Ltd. to ISO 9001/14001

