



LOCK RELEASE VALVE

MODEL LR3/LR5

Benefits

Lock release valve maximizes production of rotating cylinder dryers, presses, and other steam-using equipment by preventing steam locking of the trap. The lock release valve can be used with J3X or J5X steam traps.

1. Fine-adjustment to keep steam loss low.
2. Maintenance and repair is possible without removing the valve from the steam trap.
3. Simple construction and compact design.
4. All parts made of stainless steel.

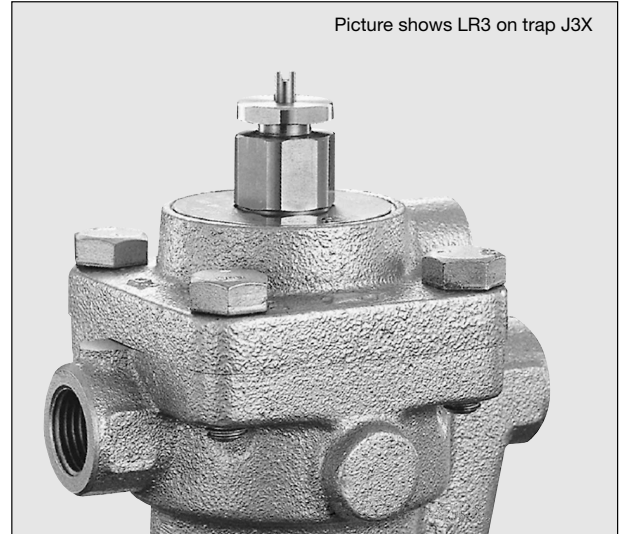

Specifications

Model	LR3	LR5
For Steam Trap Model	J3X, JF3X	J5X, JF5X
Max. Operating Pressure (psig) PMO		300*
Max. Operating Temperature (°F) TMO		428*
Maximum Allowable Pressure (psig) PMA		300*
Maximum Allowable Temperature (°F) TMA		428*

* Values are for the lock release valve itself. Actual PMO/TMO and PMA/TMA are limited to the specifications of the trap it is installed on.



CAUTION

To avoid abnormal operation, accidents or serious injury, DO NOT use this product outside of the specification range. Local regulations may restrict the use of this product to below the conditions quoted.

No.	Description	Material	ASTM/AISI*	JIS
①	Gland Case	Stainless Steel	AISI303	SUS303
②	Gasket	Fluorine Resin	PTFE	PTFE
③	Gland Packing	Graphite	—	—
④	Snap Ring	Stainless Steel	AISI304	SUS304
⑤	Element Retainer	Stainless Steel	AISI303	SUS303
⑥	Gland Retainer Nut	Stainless Steel	AISI303	SUS303

* Equivalent

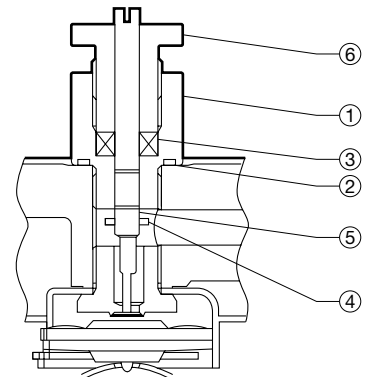

Dimensions

•LR3, LR5

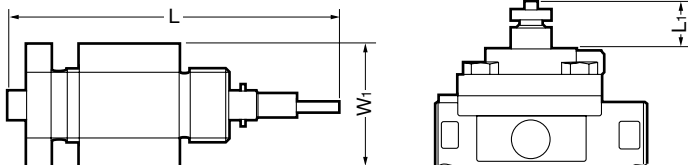

LR3, LR5

Model	L	L ₁	W ₁	Weight (lb.)
LR3	2 5/16	1 5/16	7/8	0.036
LR5	2 5/8			

(in.)

Trap Capacity (Lock Release Valve fully open)

•J(F)3X (LR3)

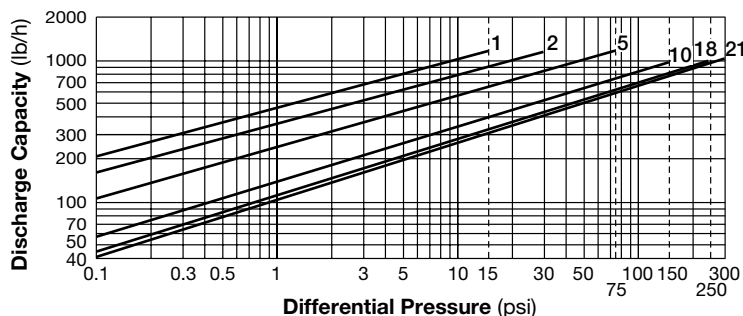

Orifices for J3X, screwed:
No. 1, 2, 5, 10, 21
Orifices for JF3X, flanged:
No. 1, 2, 5, 10, 18

1. Line numbers within the graph refer to orifice numbers.
2. Differential pressure is the difference between the inlet and outlet pressure of the trap.
3. Capacities are based on continuous discharge of condensate 11°F below saturated steam temperature.
4. Recommended safety factor: at least 1.5.
5. When the lock release valve is fully closed, the trap capacity will be as shown in the J(F) 3X and J(F)5X SDS.

•J(F)5X (LR5)

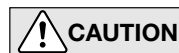
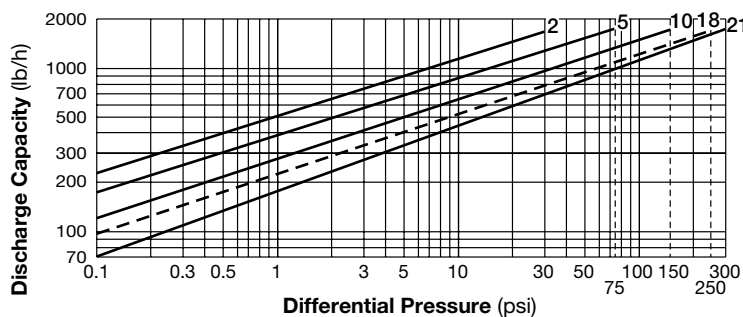

DO NOT use traps under conditions which exceed maximum differential pressure as condensate backup will occur!

Orifices for J5X, screwed:
No. 2, 5, 10, 21
Orifices for JF5X, flanged:
No. 2, 5, 10, 18*

*Available on special request.

Steam/Air Discharge through trap air vent (Lock Release Valve fully open)

•Steam

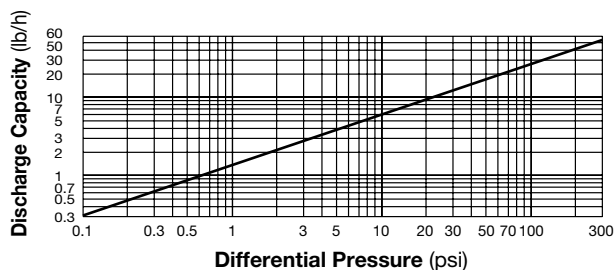

1. Differential Pressure is the difference between the inlet and outlet pressure of the trap.

•Air

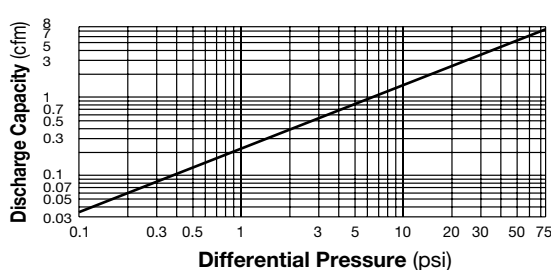

1. Differential Pressure is the difference between the inlet and outlet pressure of the trap.
2. Capacities are equivalent capacities of air at 68 °F and atmospheric pressure.



DO NOT DISASSEMBLE OR REMOVE THIS PRODUCT WHILE IT IS UNDER PRESSURE.
Allow internal pressure of this product to equal atmospheric pressure and its surface to cool to room temperature before disassembling or removing. Failure to do so could cause burns or other injury. READ INSTRUCTION MANUAL CAREFULLY.

TLV CORPORATION

13901 South Lakes Drive, Charlotte, NC 28273-6790
Phone: 704-597-9070 Fax: 704-583-1610
E-mail: tlv@tlvengineering.com
For Technical Service 1-800 "TLV TRAP"



Manufacturer
TLV CO., LTD.
Kakogawa, Japan
is approved by LRQA Ltd. to ISO 9001/14001

ISO 9001/ISO 14001

