



COSPECT® PNEUMATIC CONTROL VALVE FOR STEAM

MODEL PN-COS-16

REMOTELY CONTROLLABLE PNEUMATICALLY ACTUATED CONTROL VALVE

Benefits

Pneumatic steam conditioning control valve designed for remotely controlling steam pressure based on the technologically advanced COSPECT pressure reducing valve design, suitable for use in steam heating processes.*

1. Rapid response pneumatic actuator precisely adjusts the valve position to ensure accurate pressure control.
2. Combination conditioning system includes pressure reducing valve, condensate separator, and steam trap.
3. Unique SCE cyclone separator's 98% efficiency can deliver high quality steam of 99.8% dryness, enhancing product quality, shortening batch times, and extending downstream valve life.
4. Combining valve with a controller and electro-pneumatic transducer enables automatic PID operation.
5. Combining valve with an air regulator allows secondary pressure to be set remotely. (2 point pressure switching is also possible.)
6. Manual pressure adjustment using internal spring load allows steam to be supplied at a minimum set pressure, even if motive air is cut off.
7. Large surface area integral screens for pilot valve and main valve extend trouble-free service.

* Can be used to control processes temperature if desired temperature is controllable using secondary pressure within the Adjustable Pressure Range.



Specifications

Model	PN-COS-16	
Connection	Flanged	
Size (in)	1, 1½, 2	
Max. Operating Pressure (psig)	PMO	250
Max. Operating Temperature (°F)	TMO	428
Maximum Allowable Pressure (psig)	PMA	250
Maximum Allowable Temperature (°F)	TMA	428
Primary Pressure Range (psig)	30 - 250	
Adjustable Pressure Range (all conditions must be met)	Within 10 - 84% of primary pressure but with a minimum pressure of 5 psig	
	Max. pressure : [Motive air pressure minus 15] psig	
	Differential Pressure between 10 - 120 psi	
Minimum Adjustable Flow Rate	5% of rated flow rate	
Motive Medium	Oil-free air, filtered to 5 µm	
Required Motive Air Pressure	[Desired secondary pressure + 15] psig or higher (but not exceeding 250 psig)	

Connections and sizes in bold are standard



To avoid abnormal operation, accidents or serious injury, DO NOT use this product outside of the specification range. Local regulations may restrict the use of this product to below the conditions quoted.

Configuration

No.	Description	Material	
①	Main Body	Cast Iron	
②	Trap Body	Cast Iron	
③	Trap Cover	Cast Iron	
④	Separator	Cast Stainless Steel	
⑤	Float	Stainless Steel	
⑥	Float Cover	Cast Iron	
⑦	Trap Valve Seat	Stainless Steel	
⑧	Separator Screen	Stainless Steel	
⑨	Main Valve Seat	Stainless Steel	
⑩	Main Valve	Stainless Steel	
⑪	Main Valve Holder	Stainless Steel	
⑫	Piston	Cast Stainless Steel	
⑬	Cylinder	Stainless Steel	
⑭	Pilot Screen	Stainless Steel	
⑮	Pilot Screen Holder	Carbon Steel	
⑯	Pilot Body	Ductile Cast Iron	
⑰	Piston Guide	1"	Stainless Steel
		1 1/2", 2"	Cast Stainless Steel
⑱	Pilot Valve	Stainless Steel	
⑲	Pilot Valve Seat	Stainless Steel	
⑳	Diaphragm	Stainless Steel	
㉑	Diaphragm Support	Brass	
㉒	Spring Housing	Cast Stainless Steel	
㉓	Coil Spring	Carbon Steel	
㉔	Adjustment Screw	Carbon Steel	
㉕	Packing Retainer	Stainless Steel	
㉖	Spanner Cap	Die Cast Aluminium	
㉗	Plug - Sensing Line Port	Carbon Steel	
㉘	Nameplate	Stainless Steel	

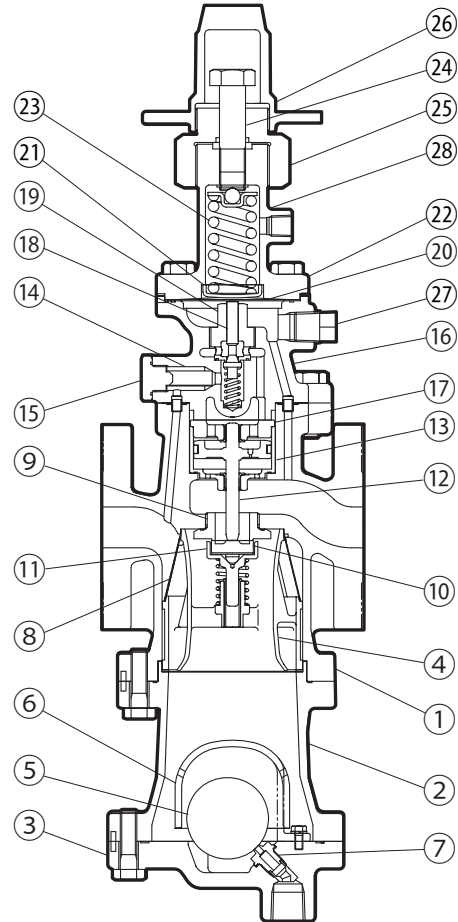

0 [] c&V SXÁ | Á q a p | ^ ^ | a & ^ (^) a s o É Ú Á a \ ^ o Á s Á Ú V Ø È

Cv Values

	Nominal Valve Size (in)		
	1"	1 1/2"	2"
Cv (US)	11.1	24.0	37.2
Cv (UK)	9.2	20.0	31.0
Kvs (DIN)	9.5	20.6	31.9

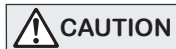

The Cv values shown are for the valve in the full fail open position. These values are not to be used for PN-COS sizing, and instead may be used as one of the factors in calculations for safety valve selection.

Capacity Table

With external (factory standard) or internal (option) secondary pressure-sensing channel or line (lb/h)

Primary Steam Press. (psig)	Secondary (Set) Steam Pressure (psig)		Nominal Valve Size (in)		
	External Line	Internal Channel (option)	1"	1 1/2"	2"
30	*20	*20	590	1335	2070
	16	16	680	1470	2280
	**5 – 14	14	700	1515	2350
		9	680	1470	2275
		**5	645	1390	2155
40	*30	*30	595	1515	2350
	25	25	800	1730	2680
	**5 – 20	20	855	1850	2870
		12	825	1780	2760
		*5	745	1615	2505
50	*40	*40	660	1675	2595
	30	30	970	2100	3255
	**5 – 25	25	1020	2200	3410
		15	930	2010	3115
		**5	815	1770	2740
60	*50	*50	715	1820	2815
	45	45	835	2120	3285
	40	40	1075	2325	3600
	**5 – 30	30	1175	2545	3945
		18	1040	2255	3495
	**5	875	1890	2935	
75	*63	*63	855	2170	3365
	60	60	930	2370	3670
	50	50	1300	2810	4350
	**5 – 38	38	1410	3050	4730
		23	1180	2550	3955
	**5	915	1985	3070	
85	*71	*71	1135	2455	3800
	70	70	1165	2520	3905
	50	50	1520	3290	5100
	**5 – 42	42	1570	3400	5270
		25	1240	2685	4165
	**5	930	2015	3130	
100	*84	*84	1300	2805	4345
	80	80	1415	3060	4740
	60	60	1740	3770	5840
	**10 – 50	50	1805	3900	6045
		30	1380	2990	4630
	**10	950	2050	3180	
125	*105	*105	1590	3435	5325
	100	100	1730	3740	5800
	80	80	2075	4490	6955
	**13 – 63	63	2190	4735	7340
		35	1470	3180	4945
	**13	910	1970	3050	
150	*126	*126	1880	4060	6295
	125	125	1910	4130	6400
	100	100	2405	5195	8050
	**30 – 75	75	2580	5575	8640
		50	2425	5270	8140
	**30	1215	2635	4085	
175	*147	*147	2170	4690	7270
	145	145	2225	4815	7465
	120	120	2730	5895	9140
	**55 – 88	88	2965	6405	9930
		70	2385	5145	7960
	*55	1850	3990	6160	
200	*168	*168	2460	5315	8240
	150	150	2885	6240	9675
	130	130	3170	6855	10625
	**80 – 100	100	3350	7240	11225
		**80	2540	5505	8530
225	*189	*189	2750	5940	9210
	175	175	3100	6705	10395
	150	150	3500	7565	11730
	**105 – 111	111	3740	8085	12530
		**105	3405	7350	11430
250	*210	*210	3040	6570	10180
	150	150	4015	8680	13450
	**130	**130	4110	8885	13770

* Maximum adjustable secondary pressure ** Minimum adjustable secondary pressure

Dimensions

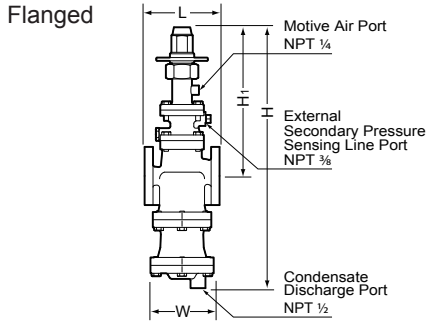

PN-COS-16 Flanged (in)

Size	L		H	H ₁	W	Weight* (lb)
	Connects to ASME Class					
	125FF	250RF				
1	6 15/16	7 3/8	22 3/16	12 3/4	5 7/8	49
1 1/2	8 1/4	8 3/4	24 3/16	13 3/16	6 1/2	63
2	10	10 1/4	26 5/8	14	7 1/2	98

Other standards available, but length and weight may vary
 * Weight is for ASME Class 250 RF

Trap Discharge Capacity

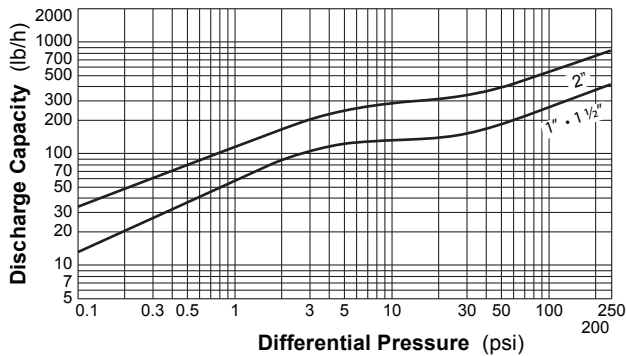

1. The discharge capacity is the maximum continuous condensate discharge 11 °F below saturated steam temperature.
2. The differential pressure is the difference between the PN-COS inlet and its trap outlet pressure.

CAUTION DO NOT use this product under conditions that exceed maximum differential pressure, as condensate backup will occur!

Usage Examples

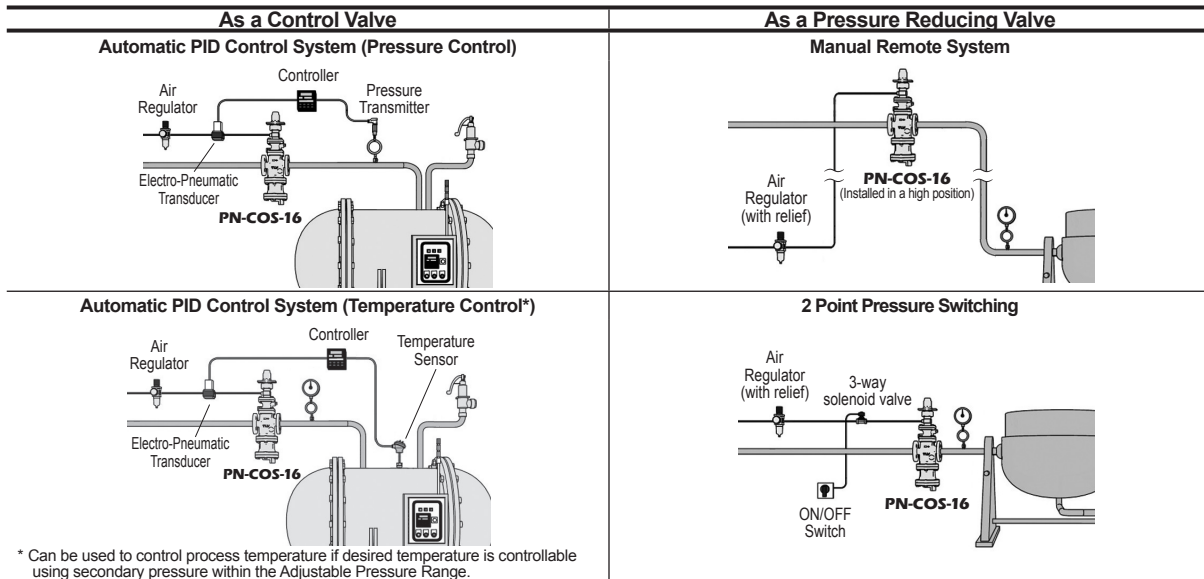

* Can be used to control process temperature if desired temperature is controllable using secondary pressure within the Adjustable Pressure Range.

For explanation purposes only, not intended as installation designs.

Option

Pressure Gauge Unit	Replaces the standard screen holder plug to enable installation of a pressure gauge of the user's choice. Primary side: M16 holder plug (male/female), BSP/Rc(PT)/NPT 3/8. An elbow is required for pressure gauge installation. Secondary side: Rc(PT) 3/8 mounting port for elbow and pressure gauge installation.
	Elbows, pressure gauge and connecting parts must be purchased separately.

● **Configuration**

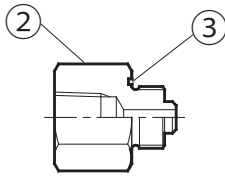

● **Installation Example**

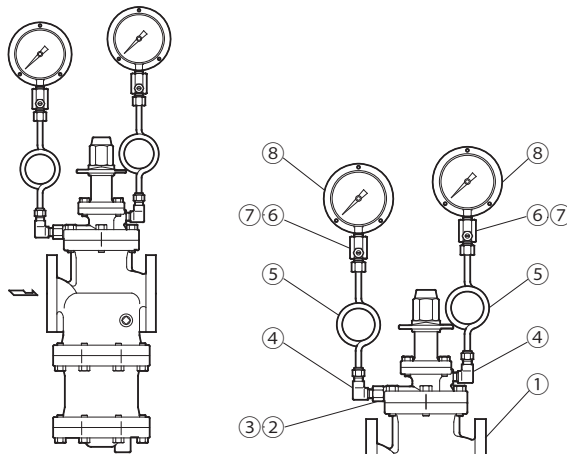

NOTE: For explanation purposes, a siphon tube style pressure gauge will be used. However, the instructions also apply to cooling tower-style pressure gauges.

No.	Part Name	No.	Part Name
1	Valve Body	5	Siphon Tube*
2	Holder Plug	6	Dampener*
3	Holder Plug Gasket	7	Dampener Gasket*
4	Elbow (male/female)*	8	Pressure Gauge*

* Purchase separately



DO NOT DISASSEMBLE OR REMOVE THIS PRODUCT WHILE IT IS UNDER PRESSURE.
Allow internal pressure of this product to equal atmospheric pressure and its surface to cool to room temperature before disassembling or removing. Failure to do so could cause burns or other injury. READ INSTRUCTION MANUAL CAREFULLY.

TLV CORPORATION

13901 South Lakes Drive, Charlotte, NC 28273-6790
Tel: 704-597-9070 Fax: 704-583-1610
E-mail: tlv@tlvengineering.com <https://www.tlv.com>
For Technical Service 1-800 "TLV TRAP"



Manufacturer
TLV CO., LTD.
Kakogawa, Japan
is approved by LRQA Ltd. to ISO 9001/14001

