



# FREE FLOAT<sup>®</sup> DRAIN TRAP

## MODEL SS1VA

### DRAIN TRAP WITH TIGHT SHUT-OFF FOR AIR AND INERT GASES

#### Benefits

**Stainless steel trap to be installed vertically in pipe ends. Automatically drains condensate from air and inert gas systems.**

1. Constant water seal and unique rotational seating design prevent concentrated wear to ensure long life.
2. Three-point seating provides a tight seal even under low-load conditions.
3. Easy, inline access to internal parts simplifies cleaning and lowers maintenance costs.
4. Built-in screen with large surface area ensures extended trouble-free service.
5. Rugged float construction with up to 1740 psig hydraulic shock rating ensures excellent performance of the trap.



#### Specifications

Model		SS1VA-R (Rubber Orifice)	SS1VA-M (Metal Orifice)
Connection		<b>Screwed</b>	
Size (in)		<b>1</b>	
Orifice No.		10	10, 21
Maximum Operating Pressure (psig)	PMO*	150	150, 300
Maximum Differential Pressure (psi)	ΔPMX*	150	150, 300
Minimum Operating Pressure (psig)		Vacuum	
Maximum Operating Temperature (°F)	TMO	212	428
Maximum Allowable Pressure (psig)	PMA	300	
Maximum Allowable Temperature (°F)	TMA	428	
Applicable Fluids*		Air, Inert Gas	

\* For specific gravities other than 1.00, use table below

**Connections and sizes in bold are standard**

Model	Orifice No.	Specific Gravity										
		1.00	0.99-0.95	0.94-0.90	0.89-0.85	0.84-0.80	0.79-0.75	0.74-0.70	0.69-0.65	0.64-0.60	0.59-0.55	0.54-0.50
Maximum Operating Pressure PMO (psig) & Maximum Differential Pressure ΔPMX (psi)												
SS1VA-R	10	150	150	150	150	148	127	105	83	61	40	18
SS1VA-M	10 21	150 300	150 300	144 300	128 300	111 290	95 247	79 205	62 162	46 120	30 78	14 35

No.	Description	Material	ASTM/AISI*	JIS
①	Body	Cast Stainless Steel	A351 Gr.CF8	—
②	Cover	Cast Stainless Steel	A351 Gr.CF8	—
③	Float	Stainless Steel	AISI316L	SUS316L
④	Orifice	SS1VA-R	NBR**/Stainless Steel	D2000BF/AISI303
		SS1VA-M	—	—
⑤	Orifice Gasket	SS1VA-R	Fluorine Resin	PTFE
		SS1VA-M	Stainless Steel	AISI316L
⑥	Screen	Stainless Steel	AISI304	SUS304
⑦	Cover Gasket	Fluorine Resin	PTFE	PTFE
⑧	Cover Bolt	Stainless Steel	AISI304	SUS304
⑨	Nameplate	Stainless Steel	AISI304	SUS304
⑩	Screw	Stainless Steel	AISI304	SUS304
⑪	Spring Washer	Stainless Steel	AISI304	SUS304
⑫	Connector	Stainless Steel	AISI304	SUS304

\* Equivalent \*\* Nitrile Rubber

**CAUTION** To avoid abnormal operation, accidents or serious injury, DO NOT use this product outside of the specification range. Local regulations may restrict the use of this product to below the conditions quoted. DO NOT use for toxic, flammable or otherwise hazardous fluids.

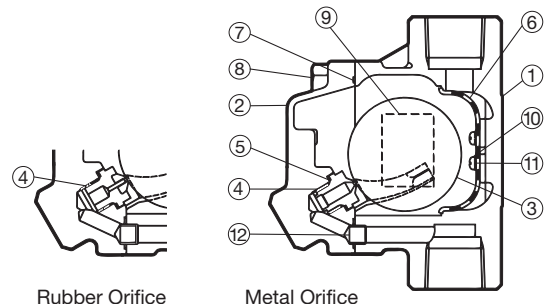

Rubber Orifice

Metal Orifice

**Dimensions**

● **SS1VA** Screwed

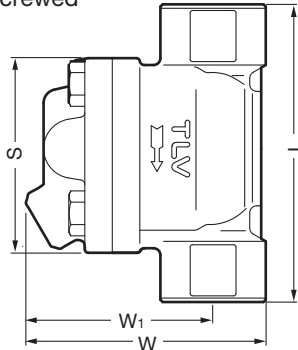

NOTE:  
Install the shortest possible vertical condensate pipe to the trap to ensure unobstructed condensate flow.

**SS1VA** Screwed\* (in)

Size	L	W	W <sub>1</sub>	S	Weight (lb)
1	5 1/8	4 1/16	3 3/16	3 1/4	4.0

\* NPT, other standards available

**Leakage Rating**

Maximum Seat Leakage

Model	Orifice	Minimum Δ P (psi)	
		0.1	1.5
SS1VA	Rubber	<0.01% of rated valve capacity	<0.15 standard ml/min, <1 bubble/min
	Metal	<0.1% of rated valve capacity	

\* Standard milliliters based on 60 °F, 14.73 psi abs

**Discharge Capacity**

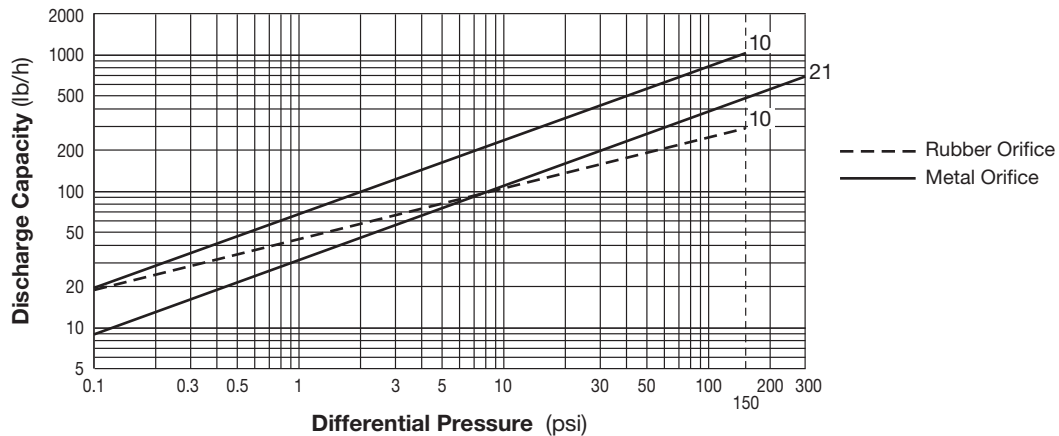

1. Line numbers within the graph refer to orifice numbers.
2. Differential pressure is the difference between the inlet and outlet pressure of the trap.
3. The chart is applicable to condensate below 212 °F.
4. The discharge capacity is for a liquid with specific gravity of 1.
5. Recommended safety factor: at least 1.5.

**CAUTION** DO NOT use this product under conditions that exceed maximum differential pressure, as condensate backup will occur!

Capacity Conversion Factors

Specific Gravity (S.G.)	0.95	0.9	0.85	0.8	0.75	0.7	0.65	0.6	0.55	0.5
Conversion Factor	1.03	1.06	1.08	1.12	1.16	1.19	1.24	1.29	1.35	1.41

Before using the capacity chart multiply the required capacity (including safety factor) by the appropriate conversion factor for the specific gravity of the liquid. Choose from the table above or use the following formula: Conversion factor =  $\frac{1}{\sqrt{S.G.}}$

**CAUTION** DO NOT DISASSEMBLE OR REMOVE THIS PRODUCT WHILE IT IS UNDER PRESSURE. Allow internal pressure of this product to equal atmospheric pressure and its surface to cool to room temperature before disassembling or removing. Failure to do so could cause burns or other injury. READ INSTRUCTION MANUAL CAREFULLY

**TLV CORPORATION**

13901 South Lakes Drive, Charlotte, NC 28273-6790  
Tel: 704-597-9070 Fax: 704-583-1610  
E-mail: [tlv@tlvengineering.com](mailto:tlv@tlvengineering.com) <https://www.tlv.com>  
For Technical Service 1-800 "TLV TRAP"



Manufacturer  
**TLV CO., LTD.**  
Kakogawa, Japan  
is approved by LRQA Ltd. to ISO 9001/14001

ISO 9001  
ISO 14001

