



**TLV**® CO., LTD.

Kakogawa, Japan

is approved by LRQA Ltd. to ISO 9001/14001



# Instruction Manual

## Process Lever Float Steam Trap SW1U-A / SW1U-B

Manufacturer

**TLV**® CO., LTD.

881 Nagasuna, Noguchi, Kakogawa, Hyogo, 675-8511, Japan

Tel: [81]-(0)79-422-1122 Fax: [81]-(0)79-422-0112

Copyright © 2019 by TLV CO., LTD. All rights reserved

**TLV** CORPORATION

## Contents

Introduction .....	2
Safety Considerations .....	3
Checking the Piping .....	5
Operation .....	5
Specifications .....	6
Configuration .....	7
Installation .....	8
Maintenance.....	10
Disassembly/Reassembly .....	11
Troubleshooting .....	12
<b>TLV</b> EXPRESS LIMITED WARRANTY .....	13

## Introduction

Thank you for purchasing the TLV process lever float steam trap.

This product has been thoroughly inspected before being shipped from the factory. When the product is delivered, before doing anything else, check the specifications and external appearance to make sure nothing is out of the ordinary. Also be sure to read this manual carefully before use and follow the instructions to be sure of using the product properly.

This steam trap employs TLY® (Tetra-Leaf & Yoke) construction, which affords it stable operation and long service life. TLY construction was developed for process lever float steam traps, and comprises a four-bladed valve connected directly to a lever float.

As the valve opening and closing forces created by the pressure differential between inlet and outlet pressures are balanced, a four-bladed valve ensures stable trap operation at all times.

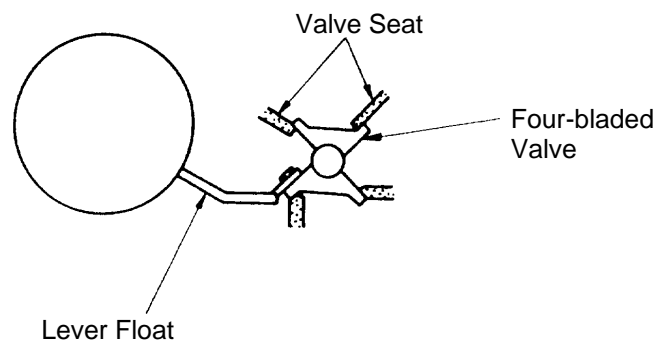

This trap is ideal for applications requiring the removal of condensate from equipment using large quantities of steam and from process machinery. Additionally, it quickly and automatically discharges large quantities of condensate at a temperature slightly lower than saturation temperature.

For products with special order specifications or options, if detailed instructions for the special order specifications or options are not contained in this manual, please contact TLV for full details.







This instruction manual is intended for use with the model(s) listed on the front cover. It is necessary not only for installation but for subsequent maintenance, disassembly/reassembly and troubleshooting. Please keep it in a safe place for future reference.

TLY is a registered trademark of TLV CO., LTD.

## Safety Considerations

- Read this section carefully before use and be sure to follow the instructions.
- Installation, inspection, maintenance, repairs, disassembly, adjustment, and valve opening/closing should be carried out only by trained maintenance personnel.
- The precautions listed in this manual are designed to ensure safety and prevent equipment damage and personal injury. For situations that may occur as a result of erroneous handling, three different types of cautionary items are used to indicate the degree of urgency and the scale of potential damage and danger: DANGER, WARNING and CAUTION.
- The three types of cautionary items above are very important for safety: be sure to observe all of them as they relate to installation, use, maintenance, and repair. Furthermore, TLV accepts no responsibility for any accidents or damage occurring as a result of failure to observe these precautions.

### Symbols

	Indicates a <b>DANGER, WARNING or CAUTION</b> item.
	Indicates an urgent situation which poses a threat of death or serious injury
	Indicates that there is a potential threat of death or serious injury
	Indicates that there is a possibility of injury or equipment / product damage
	<p><b>NEVER apply direct heat to the float.</b> The float may explode due to increased internal pressure, causing accidents leading to serious injury or damage to property and equipment.</p>
	<p><b>Install properly and DO NOT use this product outside the recommended operating pressure, temperature and other specification ranges.</b> Improper use may result in such hazards as damage to the product or malfunctions that may lead to serious accidents. Local regulations may restrict the use of this product to below the conditions quoted.</p> <p><b>DO NOT use this product in excess of the maximum operating pressure differential.</b> Such use could make discharge impossible (blocked).</p> <p><b>Use hoisting equipment for heavy objects (weighing approximately 20 kg (44 lb) or more).</b> Failure to do so may result in back strain or other injury if the object should fall.</p>

Continued on the next page

 <b>CAUTION</b>	<p><b>Take measures to prevent people from coming into direct contact with product outlets.</b> Failure to do so may result in burns or other injury from the discharge of fluids.</p>
	<p><b>When disassembling or removing the product, wait until the internal pressure equals atmospheric pressure and the surface of the product has cooled to room temperature.</b> Disassembling or removing the product when it is hot or under pressure may lead to discharge of fluids, causing burns, other injuries or damage.</p>
	<p><b>Be sure to use only the recommended components when repairing the product, and NEVER attempt to modify the product in any way.</b> Failure to observe these precautions may result in damage to the product and burns or other injury due to malfunction or the discharge of fluids.</p>
	<p><b>Use only under conditions in which no freeze-up will occur.</b> Freezing may damage the product, leading to fluid discharge, which may cause burns or other injury.</p>
	<p><b>Use only under conditions in which no water hammer will occur.</b> The impact of water hammer may damage the product, leading to fluid discharge, which may cause burns or other injury.</p>

## Checking the Piping



Use only under conditions in which no water hammer will occur. The impact of water hammer may damage the product, leading to fluid discharge, which may cause burns or other injury.

Check to make sure that the pipes to be connected to the trap have been installed properly.

1. Is the pipe diameter suitable?
2. Is the piping where the trap is to be installed horizontal?
3. Has sufficient space been secured for maintenance?
4. Have isolation valves been installed at the inlet and outlet? If the outlet is subject to back pressure, has a check valve been installed?
5. Has a bypass line been installed properly?
6. Is the inlet pipe as short as possible, with as few bends as possible, and installed so the liquid will flow naturally down into the trap?

## Operation

Principles of condensate discharge:

At start-up, open the bypass valve to remove any initial condensate or air at 100°C (212°F) or less. (This step must be performed in order to ensure smooth start-up.)

Air binding occurs when the inflow of steam is accompanied by the inflow of air during normal operation. Whenever air binding occurs, it can be released by opening the bellows sealed valve to discharge the air.

After air is discharged, the bellows sealed valve must be closed.

As condensate flows into the trap, the rising condensate level causes the float to rise due to buoyancy, automatically opening the valve and allowing condensate to be continuously discharged. When this occurs, the opening size of the valve varies depending on the condensate flow rate.

As the condensate is discharged, the condensate level falls, causing the float to fall, thereby automatically closing the valve.

The valve remains closed as long as no condensate enters the trap.

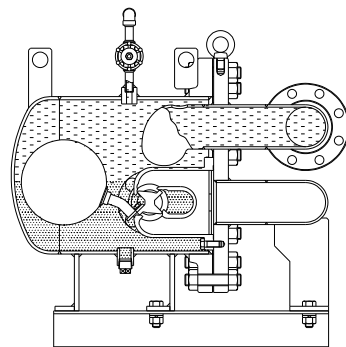
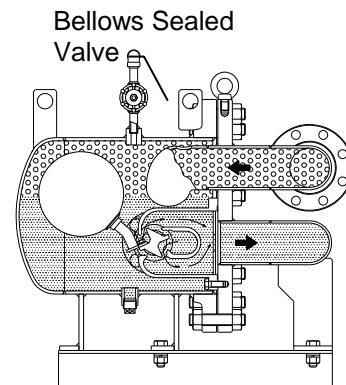

## Specifications



Install properly and **DO NOT** use this product outside the recommended operating pressure, temperature and other specification ranges. Improper use may result in such hazards as damage to the product or malfunctions which may lead to serious accidents. Local regulations may restrict the use of this product to below the conditions quoted.



**DO NOT** use this product in excess of the maximum operating pressure differential; such use could make discharge impossible (blocked).



Use only under conditions in which no freeze-up will occur. Freezing may damage the product, leading to fluid discharge, which may cause burns or other injury.

Refer to the product nameplate for detailed specifications.

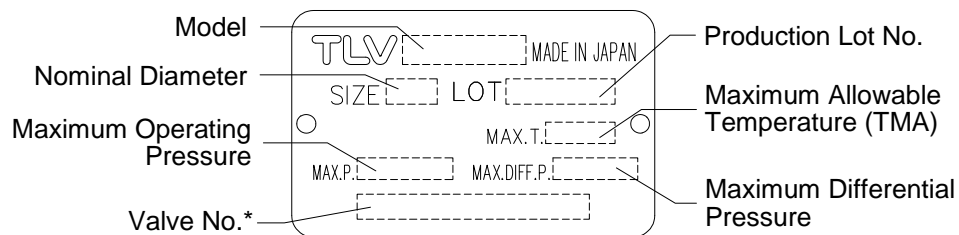

\* Valve No. is displayed for products with options. This item is omitted from the nameplate when there are no options.

## Configuration

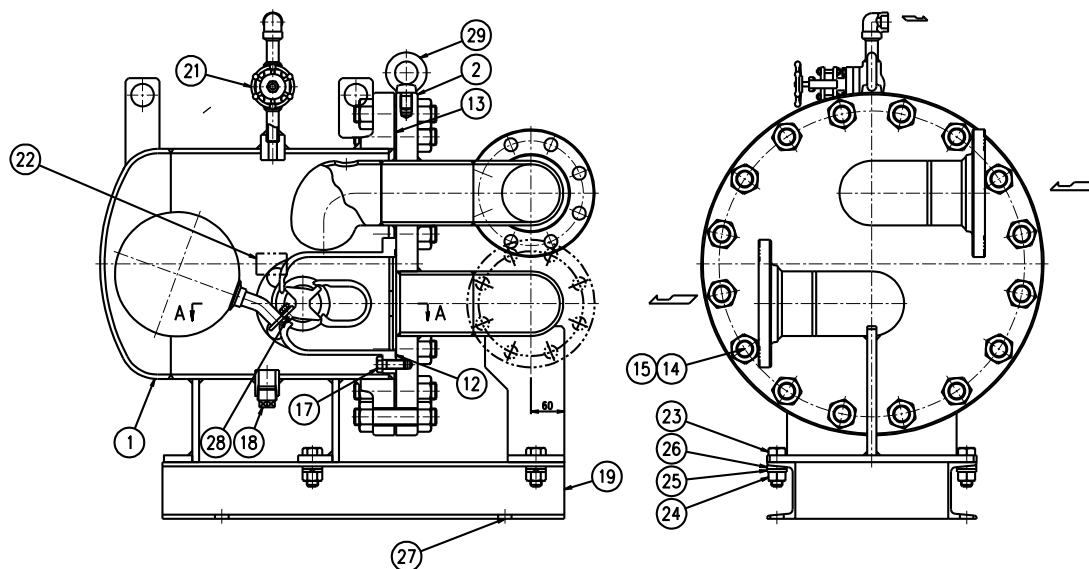

A-A Cut View (SW1U-A)

A-A Cut View (SW1U-B)

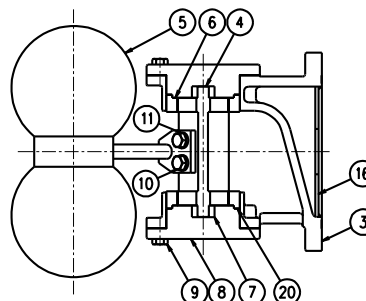
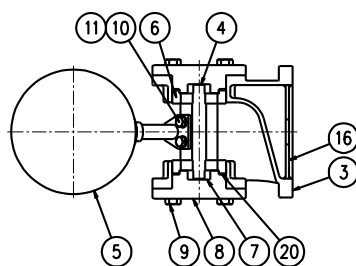

No.	Name	No.	Name	No.	Name
1	Body Unit	11	Spring Washer	21	Bellows Sealed Valve
2	Cover Unit	12	Valve Seat Body Gasket	22	Nameplate
3	Valve Seat Body	13	Cover Gasket	23	Mounting Bolt
4	TLY Valve	14	Cover Bolt	24	Mounting Nut
5	Float Unit	15	Cover Nut	25	Spring Washer
6	Seal Ring	16	Baffle	26	Washer
7	Bearing	17	Valve Seat Body Bolt	27	Foundation Bolt
8	Valve Holder	18	Drain Plug	28	Set Screw
9	Valve Holder Bolt	19	Mounting Base	29	Eye Bolt
10	Lever Bolt	20	Wave Spring		



## Installation



Install properly and **DO NOT** use this product outside the recommended operating pressure, temperature and other specification ranges. Improper use may result in such hazards as damage to the product or malfunctions which may lead to serious accidents. Local regulations may restrict the use of this product to below the conditions quoted.



Use hoisting equipment for heavy objects (weighing approximately 20 kg (44 lb) or more). Failure to do so may result in back strain or other injury if the object should fall.



Take measures to prevent people from coming into direct contact with product outlets. Failure to do so may result in burns or other injury from the discharge of fluids.

Installation, inspection, maintenance, repairs, disassembly, adjustment and valve opening/closing should be carried out only by trained maintenance personnel.

1. Before installation, be sure to remove all protective seals.
2. When installing the product, be sure to install a bypass line. At start-up, open the bypass valve to remove initial condensate and air of less than 100°C (212°F).
3. Install an inlet valve and strainer at the trap inlet.
4. Before installing the product, open the inlet valve and blow out the piping to remove any piping scraps, dirt and oil. Close the inlet valve after blowdown.
5. Install an outlet pipe with consideration for maintenance work from the bellows sealed valve for the discharge of air safely to a drainage vessel or ditch. Make sure the end of the pipe is above the waterline, so that dirt and water cannot be sucked up by vacuum when the system shuts down and the bellows sealed valve is open.
6. Secure the product to the mounting base using the 4 foundation bolts.
7. A shut-off valve should be installed at the product outlet.
8. Install the product so the arrow on the body is pointing in the direction of condensate flow.
9. Install the product into the piping in a manner that lets the condensate flow naturally down into the trap.
10. Secure the necessary space to perform a complete disassembly and inspection. (See the figures on the next page.)

If there is a problem, determine the cause using the “Troubleshooting” section in this manual.

**SW1U-A**

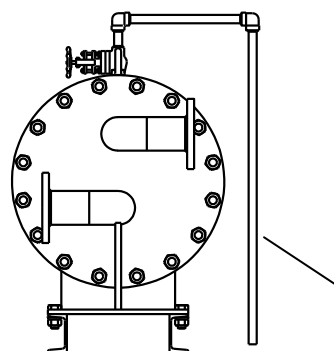
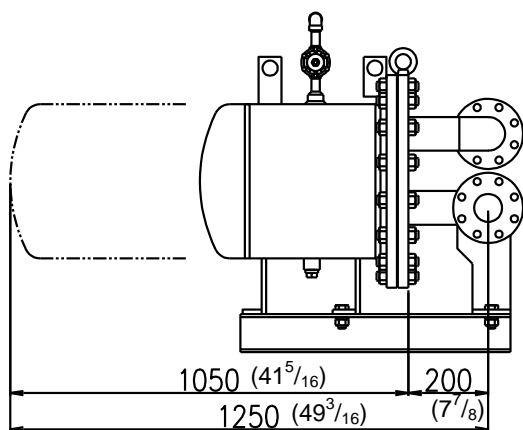

Install outlet pipe for air discharge to the safe place

**SW1U-B**

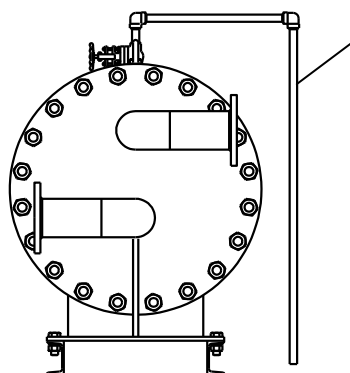
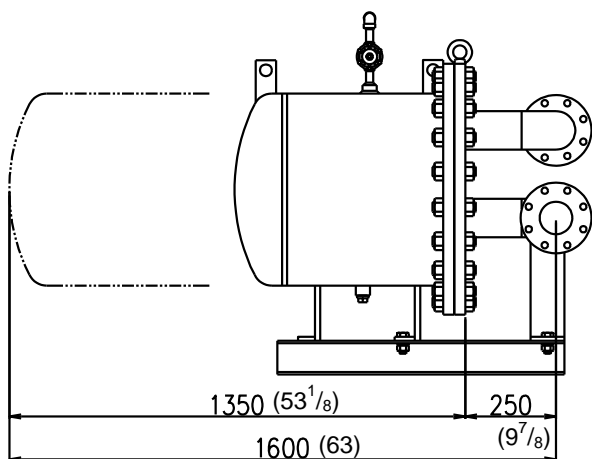

(Units: mm (in) )

## Maintenance



Take measures to prevent people from coming into direct contact with product outlets. Failure to do so may result in burns or other injury from the discharge of fluids.



Be sure to use only the recommended components when repairing the product, and NEVER attempt to modify the product in any way. Failure to observe these precautions may result in damage to the product or burns or other injury due to malfunction or the discharge of fluids.

## Operational Check

A visual inspection of the following items should be done on a daily basis to determine whether the product is operating properly or has failed. Periodically (at least once every six months) the operation should also be checked by using diagnostic equipment, such as a stethoscope or thermometer. A complete disassembly and inspection should be performed at least once every 3 years.

If the product should fail, it may cause damage to piping and equipment, resulting in faulty or low quality products or losses due to steam leakage.

- Normal : Condensate is discharged continuously, together with flash steam, and the sound of flow can be heard. If there is very little condensate, there is almost no sound of flow.
- Blocked (Discharge Impossible) : No condensate is discharged. The trap is quiet and makes no noise, and the surface temperature of the trap is low.
- Blowing : Live steam continually flows from the outlet and there is a continuous metallic sound.
- Steam Leakage : Live steam is discharged through the trap outlet together with condensate, accompanied by a high-pitched sound.

### NOTE:

Flash steam: White jet containing water droplets

Live steam: Clear, slightly bluish jet

## Parts Inspection

When parts have been removed, or during periodic inspections, use the following table to inspect the parts and replace any that are found to be defective.

Procedure
Gaskets: Check for damage and warping
Float: Check for breakage, deformation and water on the inside
Seal Ring, Bearing: Check for breakage and wear
Valve, Valve Seat Body: Check for dirt build-up, damage and deformation

## Disassembly/Reassembly



### WARNING

NEVER apply direct heat to the float. The float may explode due to increased internal pressure, causing accidents leading to serious injury or damage to property and equipment.



### CAUTION

Use hoisting equipment for heavy objects (weighing approximately 20 kg (44 lb) or more). Failure to do so may result in back strain or other injury if the object should fall.



### CAUTION

When disassembling or removing the product, wait until the internal pressure equals atmospheric pressure and the surface of the product has cooled to room temperature. Disassembling or removing the product when it is hot or under pressure may lead to discharge of fluids, causing burns, other injuries or damage.

Use the following procedures to remove components. Use the same procedures in reverse to reassemble. (Installation, inspection, maintenance, repairs, disassembly, adjustment and valve opening/closing should be carried out only by trained maintenance personnel.)

### Disassembly/Reassembly

Part	During Disassembly	During Reassembly
Bellows Sealed Valve	Slowly open before disassembling the trap and make sure no remained pressure in the trap	Close after reassembling the trap
Body Unit	Loosen and remove the cover nuts and bolts connecting the body unit and cover unit	Consult the table of tightening torques and tighten cover nuts to the proper torque
Cover Gasket	Remove the gasket and clean sealing surfaces	Replace with a new gasket
Valve Seat Body	Loosen the valve seat body bolts and remove from the cover unit	Consult the table of tightening torques and tighten valve seat body bolts to the proper torque
Valve Seat Body Gasket	Remove the gasket and clean sealing surfaces	Replace with a new gasket if warped or damaged
Float Unit	Remove the lever bolts, then remove from the valve	Consult the table of tightening torques and tighten lever bolts to the proper torque;
TLY Valve	Remove the valve holder bolts from the valve seat body, remove the valve holder and then remove the TLY valve	Consult the table of tightening torques and tighten flange bolts to the proper torque
Seal Ring, Bearing	Remove from the valve seat body	Replace with new rings if warped or damaged

**Table of Tightening Torques**

Part	SW1U-A				SW1U-B			
	Torque		Distance Across Flats		Torque		Distance Across Flats	
	N·m	(lbf·ft)	mm	(in)	N·m	(lbf·ft)	mm	(in)
Cover Nut	300	(220)	30	(1 <sup>3</sup> / <sub>16</sub> )	1,200	(890)	46	(1 <sup>13</sup> / <sub>16</sub> )
Valve Seat Body Bolt	100	(73)	24	(1 <sup>5</sup> / <sub>16</sub> )	350	(260)	30	(1 <sup>3</sup> / <sub>16</sub> )
Valve Holder Bolt	100	(73)	24	(1 <sup>5</sup> / <sub>16</sub> )	120	(88)	24	(1 <sup>5</sup> / <sub>16</sub> )
Lever Bolt	35	(26)	16	(5/ <sub>8</sub> )	150	(110)	24	(1 <sup>5</sup> / <sub>16</sub> )

NOTE: -Coat all threaded portions with anti-seize. (1 N·m ≈ 10 kg·cm)  
 -If drawings or other special documentation were supplied for the product, any torque given there takes precedence over values shown here.

## Troubleshooting



**NEVER** apply direct heat to the float. The float may explode due to increased internal pressure, causing accidents leading to serious injury or damage to property and equipment.



When disassembling or removing the product, wait until the internal pressure equals atmospheric pressure and the surface of the product has cooled to room temperature. Disassembling or removing the product when it is hot or under pressure may lead to discharge of fluids, causing burns, other injuries or damage.

When the product fails to operate properly, use the following table to locate and cause the remedy.

Problem	Cause	Remedy
No condensate is discharged	The float is damaged or filled with condensate	Replace with a new float unit
	The valve is stuck closed	Disassemble, inspect, clean
	The inlet strainer has become clogged	Clean the strainer
Condensate discharge is poor	The inlet pressure is too small or the back pressure is too large	Adjust the pressure
	The inlet strainer has become clogged	Clean the strainer
Steam is blowing	The valve or valve seat body have a build-up of dirt	Disassemble, inspect, clean
	The valve or valve seat body are damaged or deformed	Replace with a new valve and/or valve seat body
	The valve is stuck closed	Disassemble, inspect, clean

## TLV EXPRESS LIMITED WARRANTY

Subject to the limitations set forth below, TLV Corporation, a North Carolina corporation (“**TLV**”) warrants that products which are sold by it or TLV International, Inc., a Japanese corporation (“**TII**”), which products (the “**Products**”) are designed and manufactured by TLV Co., Ltd., a Japanese corporation (“**TLVJ**”), conform to the specifications published by TLV for the corresponding part numbers (the “**Specifications**”) and are free from defective workmanship and materials. With regard to products or components manufactured by unrelated third parties (the “**Components**”), TLV provides no warranty other than the warranty from the third party manufacturer(s).

### Exceptions To Warranty

This warranty does not cover defects or failures caused by:

1. improper shipping, installation, use, handling, etc., by other than TLV or service representatives authorized by TLV; or
2. dirt, scale or rust, etc.; or
3. improper disassembly and reassembly, or inadequate inspection and maintenance by other than TLV or service representatives authorized by TLV; or
4. disasters or forces of nature; or
5. abuse, abnormal use, accidents or any other cause beyond the control of TLV; or
6. improper storage, maintenance or repair; or
7. operation of the Products not in accordance with instructions issued with the Products or with accepted industry practices; or
8. use for a purpose or in a manner for which the Products were not intended; or
9. use of the Products in a manner inconsistent with the Specifications; or
10. failure to follow the instructions contained in the TLV Instruction Manual for the Product.

### Duration Of Warranty

This warranty is effective for a period of the earlier of: (i) three (3) years after delivery of Products to the first end user in the case of sealed SST-Series Products for use in steam pressure service up to 650 psig; (ii) two (2) years after delivery of Products to the first end user in the case of PowerTrap® units; or (iii) one (1) year after delivery of Products to the first end user in the case of all other Products. Notwithstanding the foregoing, asserting a claim under this warranty must be brought by the earlier of one of the foregoing periods, as applicable, or within five (5) years after the date of delivery to the initial buyer if not sold initially to the first end user.

ANY IMPLIED WARRANTIES NOT NEGATED HEREBY WHICH MAY ARISE BY OPERATION OF LAW, INCLUDING THE IMPLIED WARRANTIES OF MERCHANTABILITY AND FITNESS FOR A PARTICULAR PURPOSE AND ANY EXPRESS WARRANTIES NOT NEGATED HEREBY, ARE GIVEN SOLELY TO THE INITIAL BUYER AND ARE LIMITED IN DURATION TO ONE (1) YEAR FROM THE DATE OF SHIPMENT BY TLV.

### Exclusive Remedy

THE EXCLUSIVE REMEDY UNDER THIS WARRANTY, UNDER ANY EXPRESS WARRANTY OR UNDER ANY IMPLIED WARRANTIES NOT NEGATED HEREBY (INCLUDING THE IMPLIED WARRANTIES OF MERCHANTABILITY AND FITNESS FOR A PARTICULAR PURPOSE), IS **REPLACEMENT**; PROVIDED: (a) THE CLAIMED DEFECT IS REPORTED TO TLV IN WRITING WITHIN THE APPLICABLE WARRANTY PERIOD, INCLUDING A DETAILED WRITTEN DESCRIPTION OF THE CLAIMED DEFECT AND HOW AND WHEN THE CLAIMED DEFECTIVE PRODUCT WAS USED; AND (b) THE CLAIMED DEFECTIVE PRODUCT AND A COPY OF THE PURCHASE INVOICE IS RETURNED TO TLV, FREIGHT AND

TRANSPORTATION COSTS PREPAID, UNDER A RETURN MATERIAL AUTHORIZATION AND TRACKING NUMBER ISSUED BY TLV. ALL LABOR COSTS, SHIPPING COSTS, AND TRANSPORTATION COSTS ASSOCIATED WITH THE RETURN OR REPLACEMENT OF THE CLAIMED DEFECTIVE PRODUCT ARE SOLELY THE RESPONSIBILITY OF BUYER OR THE FIRST END USER. TLV RESERVES THE RIGHT TO INSPECT ON THE FIRST END USER'S SITE ANY PRODUCTS CLAIMED TO BE DEFECTIVE BEFORE ISSUING A RETURN MATERIAL AUTHORIZATION. SHOULD SUCH INSPECTION REVEAL, IN TLV'S REASONABLE DISCRETION, THAT THE CLAIMED DEFECT IS NOT COVERED BY THIS WARRANTY, THE PARTY ASSERTING THIS WARRANTY SHALL PAY TLV FOR THE TIME AND EXPENSES RELATED TO SUCH ON-SITE INSPECTION.

#### **Exclusion Of Consequential And Incidental Damages**

IT IS SPECIFICALLY ACKNOWLEDGED THAT THIS WARRANTY, ANY OTHER EXPRESS WARRANTY NOT NEGATED HEREBY, AND ANY IMPLIED WARRANTY NOT NEGATED HEREBY, INCLUDING THE IMPLIED WARRANTIES OF MERCHANTABILITY AND FITNESS FOR A PARTICULAR PURPOSE, DO NOT COVER, AND NEITHER TLV, TII NOR TLVJ WILL IN ANY EVENT BE LIABLE FOR, INCIDENTAL OR CONSEQUENTIAL DAMAGES, INCLUDING, BUT NOT LIMITED TO LOST PROFITS, THE COST OF DISASSEMBLY AND SHIPMENT OF THE DEFECTIVE PRODUCT, INJURY TO OTHER PROPERTY, DAMAGE TO BUYER'S OR THE FIRST END USER'S PRODUCT, DAMAGE TO BUYER'S OR THE FIRST END USER'S PROCESSES, LOSS OF USE, OR OTHER COMMERCIAL LOSSES. WHERE, DUE TO OPERATION OF LAW, CONSEQUENTIAL AND INCIDENTAL DAMAGES UNDER THIS WARRANTY, UNDER ANY OTHER EXPRESS WARRANTY NOT NEGATED HEREBY OR UNDER ANY IMPLIED WARRANTY NOT NEGATED HEREBY (INCLUDING THE IMPLIED WARRANTIES OF MERCHANTABILITY AND FITNESS FOR A PARTICULAR PURPOSE) CANNOT BE EXCLUDED, SUCH DAMAGES ARE EXPRESSLY LIMITED IN AMOUNT TO THE PURCHASE PRICE OF THE DEFECTIVE PRODUCT. THIS EXCLUSION OF CONSEQUENTIAL AND INCIDENTAL DAMAGES, AND THE PROVISION OF THIS WARRANTY LIMITING REMEDIES HEREUNDER TO REPLACEMENT, ARE INDEPENDENT PROVISIONS, AND ANY DETERMINATION THAT THE LIMITATION OF REMEDIES FAILS OF ITS ESSENTIAL PURPOSE OR ANY OTHER DETERMINATION THAT EITHER OF THE ABOVE REMEDIES IS UNENFORCEABLE, SHALL NOT BE CONSTRUED TO MAKE THE OTHER PROVISIONS UNENFORCEABLE.

#### **Exclusion Of Other Warranties**

THIS WARRANTY IS IN LIEU OF ALL OTHER WARRANTIES, EXPRESS OR IMPLIED, AND ALL OTHER WARRANTIES, INCLUDING BUT NOT LIMITED TO THE IMPLIED WARRANTIES OF MERCHANTABILITY AND FITNESS FOR A PARTICULAR PURPOSE, ARE EXPRESSLY DISCLAIMED.

#### **Severability**

Any provision of this warranty which is invalid, prohibited or unenforceable in any jurisdiction shall, as to such jurisdiction, be ineffective to the extent of such invalidity, prohibition or unenforceability without invalidating the remaining provisions hereof, and any such invalidity, prohibition or unenforceability in any such jurisdiction shall not invalidate or render unenforceable such provision in any other jurisdiction.

## **TLV CORPORATION**

13901 South Lakes Drive, Charlotte, NC 28273-6790, U.S.A.

Tel: [1]-704-597-9070 Fax: [1]-704-583-1610