



FREE FLOAT® GAS TRAP MODEL GAS2N

STEEL GAS TRAP WITH TIGHT SHUT-OFF FOR INERT AND HAZARDOUS GASES

Benefits

High pressure, inline repairable free float trap with tight shut-off. Automatically drains condensate from air and gas systems.

1. Constant water seal and unique rotational seating design eliminate concentrated wear to ensure long life.
2. Three-point seating provides a tight seal even under no-load conditions (with rubber orifice).
3. Easy, inline access to internal parts simplifies cleaning and lowers maintenance costs.



Specifications

Model	GAS2N (Metal Orifice)			GAS2N (Rubber Orifice)		
	Screwed	Socket Weld	Flanged	Screwed	Socket Weld	Flanged
Connection						
Size (in)	1/2, 3/4, 1			1/2, 3/4, 1		
Orifice No.	5, 10, 21, 45			10, 21, 45		
Maximum Operating Pressure (psig) PMO**	75, 150, 300, 640			150, 300, 640		
Maximum Differential Pressure (psi) ΔPMX**	75, 150, 300, 640			150, 300, 640		
Minimum Operating Pressure (psig)	Vacuum			Vacuum		
Maximum Operating Temperature (°F) TMO	572 (S)*, 662 (C)*			302		
Maximum Allowable Pressure (psig) PMA	640			640		
Maximum Allowable Temperature (°F) TMA	572 (S)*, 662 (C)*			572 (S)*, 662 (C)*		

* (S) = Stainless steel version (C) = Cast steel version ** For specific gravities other than 1.00, use table below **GAS2N is a non-standard product, consult TLV for delivery time required**

Orifice No.		Specific Gravity							
		1.00 - 0.85	0.84 - 0.80	0.79 - 0.75	0.74 - 0.70	0.69 - 0.65	0.64 - 0.60	0.59 - 0.55	
		Max. Operating Pressure PMO (psig) & Max. Differential Pressure ΔPMX (psi)							
10	Rubber	150	150	120	97	76	50	26	
		21	300	300	250	201	151	101	52
		45	640	640	586	442	335	230	117
5	Metal	75	75	59	50	37	24	13	
		10	150	150	120	97	76	50	26
		21	300	300	250	201	151	101	52
45	640	640	586	442	335	230	117		

CAUTION

To avoid abnormal operation, accidents or serious injury, DO NOT use this product outside of the specification range. Local regulations may restrict the use of this product to below the conditions quoted.

Consult TLV for use with toxic, flammable or otherwise hazardous gases.

No.	Description	Material	ASTM/AISI*	JIS
①	Body	Cast Steel	A216 Gr.WCB	—
②	Cover	Carbon Steel	AISI1025	S25C
③	Orifice (Metal)	—	—	—
	Orifice (Rubber)	Fluorine Rubber/Stainl. Stl.	D2000HK/AISI304	FPM/SUS304
④	Float	Stainless Steel	AISI316L	SUS316L
⑤	Orifice Gasket	Soft Iron	AISI1010	SUYP
⑥	Cover Gasket	Graphite/Stainless Steel	-/AISI304	-/SUS304
⑦	Cover Bolt	Alloy Steel	A193 Gr.B16	SNB16
⑧	Cover Nut	Carbon Steel	AISI1045	S45C
⑨	Plug	Stainless Steel	AISI303	SUS303
⑩	Plug Gasket	Soft Iron	AISI1010	SUYP
⑪	Nameplate	Stainless Steel	AISI304	SUS304
⑫	Drain Plug**	Carbon/Cast Steel	AISI1025	S25C
⑬	Drain Plug Gasket**	Soft Iron	AISI1010	SUYP
⑭	Flange/Socket***	Carbon Steel***	A105/A216 Gr.WCB	-/-
⑮	Guide Pin	Stainless Steel	AISI304	SUS304
⑯	Bushing	Stainless Steel	AISI303	SUS303
⑰	Eye Bolt	Carbon Steel	A6	SS400

* Equivalent ** Shown on reverse *** Material depends on flange specifications

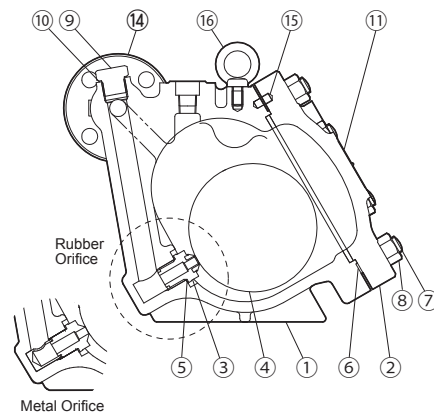

Options

1. Body material stainless steel.
2. Flanged or screwed balancing port connection.
3. Orifice material EPDM (ethylene propylene rubber), TMO 212 °F.

Leakage Rating

Maximum Seat Leakage

Model	Orifice	Minimum ΔP (psi)
		0.1
GAS2N	Rubber	<0.15 standard ml/min, <1 bubble/min
	Metal	<0.1% of rated valve capacity

* Standard milliliters based on 60 °F, 14.73 psi abs.

Dimensions

● **GAS2N** Screwed & Socket Weld

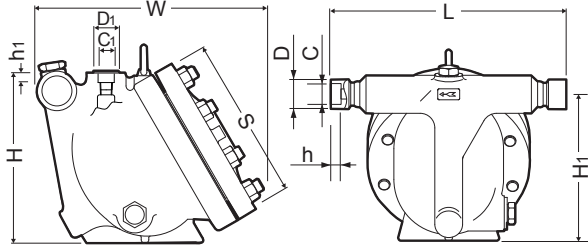

● **GAS2N** Flanged

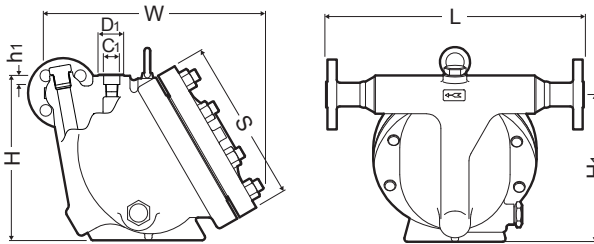

NOTE:

A pressure balancing line must be connected to the gas or air system from the balancing port at the top of the trap to a place above any possible condensate accumulation in the system.

GAS2N Screwed* (in)

Size	L	H	H ₁	W	φ S	Weight (lb)
1/2						53
3/4	9 13/16	8 7/8	7 7/8	11 13/16	8 3/4	55
1						

* NPT, other standards available

GAS2N Socket Weld* (in)

Size	L	H	H ₁	W	φ S	φ D	φ C	h	Weight (lb)
1/2						1 5/16	0.855		53
3/4	12 3/16	8 7/8	7 7/8	11 13/16	8 3/4	1 9/16	1.065	1/2	55
1						1 7/8	1.330		

* ASME B16.2005, other standards available

GAS2N Flanged (in)

Size	L				H	H ₁	W	φ S	Weight* (lb)
	Connects to ASME Class								
1/2	150RF	300RF	600RF	900RF	8 7/8	7 7/8	11 13/16	8 3/4	57
									59
1									62

Other standards available, but length and weight may vary

* Weight is for Class 600RF

Balancing Port Dimensions (in)

Pipe Size	φ D ₁	φ C ₁	h ₁
1/2	1 5/16	0.855	1/2
3/4	1 9/16	1.065	
1	1 7/8	1.330	

Discharge Capacity

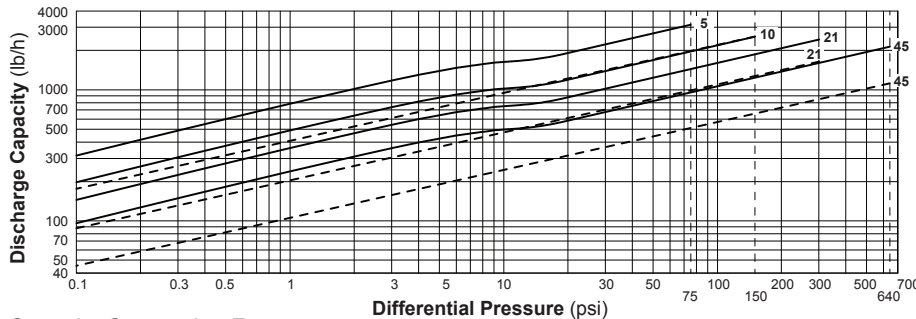

--- Rubber Orifice
 ——— Metal Orifice

1. Line numbers within the graph refer to orifice numbers.
2. Differential pressure is the difference between the inlet and outlet pressure of the trap.
3. The chart is applicable to condensate below 212°F (Rubber Orifice) or 111°F below saturated steam temperature (Metal Orifice).
4. The discharge capacity is for a liquid with specific gravity of 1.
5. Recommended safety factor: at least 1.5

Capacity Conversion Factors

Specific Gravity (S.G.)	0.95	0.9	0.85	0.8	0.75	0.7	0.65	0.6	0.55
Conversion Factor	1.03	1.06	1.08	1.12	1.16	1.19	1.24	1.29	1.35

Before using the capacity chart multiply the required capacity (including safety factor) by the appropriate conversion factor for the specific gravity of the liquid. Choose from the table above or use the following formula: Conversion factor = $\frac{1}{\sqrt{S.G.}}$

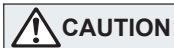

DO NOT DISASSEMBLE OR REMOVE THIS PRODUCT WHILE IT IS UNDER PRESSURE. Allow internal pressure of this product to equal atmospheric pressure and its surface to cool to room temperature before disassembling or removing. Failure to do so could cause burns or other injury. READ INSTRUCTION MANUAL CAREFULLY.

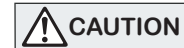

DO NOT use traps under conditions that exceed maximum differential pressure, as condensate backup will occur!

TLV CORPORATION

13901 South Lakes Drive, Charlotte, NC 28273-6790
 Tel: 704-597-9070 Fax: 704-583-1610
 E-mail: tlv@tlvengineering.com <https://www.tlv.com>
 For Technical Service 1-800 "TLV TRAP"



Manufacturer
TLV CO., LTD.
 Kakogawa, Japan
 is approved by LRQA Ltd. to ISO 9001/14001

