



FREE FLOAT STEAM TRAP

MODEL JH3LX/JH3LB

STAINLESS STEEL FREE FLOAT AND THERMOSTATIC STEAM TRAPS WITH THREE-POINT SEATING

Benefits

Inline repairable stainless steel traps with tight shut-off for drainage of superheated high pressure steam mains, turbines, and process heaters.

1. Constant water seal and unique three-point seating ensure perfect steam-tight seal, even under no-load conditions.
2. Easy, inline access to internals to simplify cleaning and lower maintenance costs.
3. Up to 1740 psig hydraulic shock rating ensures excellent resistance of the float to water hammer.
4. Durable air vent provides exceptional performance.
5. Extremely soft near-to-steam, temperature discharge for safety and environmental considerations.
6. Built-in screen for extended trouble-free service.



Specifications

Model	JH3LX			JH3LB		
	Screwed	Socket Weld	Flanged	Screwed	Socket Weld	Flanged
Connection						
Size (in)	1/2, 3/4, 1		1/2, 3/4, 1	1/2, 3/4, 1		1/2, 3/4, 1
Orifice No.	2, 5, 10, 14, 22, 32			30, 75, 150, 200, 315, 450		
Maximum Operating Pressure (psig) PMO	30, 75, 150, 200, 315, 450			30, 75, 150, 200, 315, 450		
Maximum Differential Pressure (psi) ΔPMX	30, 75, 150, 200, 315, 450			30, 75, 150, 200, 315, 450		
Minimum Operating Pressure (psig)	Vacuum			1.5		
Maximum Operating Temperature (°F) TMO	464			662		
Maximum Allowable Pressure (psig) PMA	450			662		
Maximum Allowable Temperature (°F) TMA	662			662		
Type of Air Vent	X-element			Bimetal		

CAUTION To avoid abnormal operation, accidents or serious injury, DO NOT use this product outside of the specification range. Local regulations may restrict the use of this product to below the conditions quoted.

No.	Description	Material	ASTM/AIS*	JIS
①	Body	Cast Stainless Steel	A351 Gr.CF8	—
②	Cover	Cast Stainless Steel	A351 Gr.CF8	—
③ ^F	Float	Stainless Steel	AISI316L	SUS316L
④ ^R	Orifice	—	—	—
⑤ ^{MR}	Orifice Gasket	Stainless Steel	AISI316L	SUS316L
⑥	Orifice Plug	Stainless Steel	AISI303	SUS303
⑦ ^{MR}	Orifice Plug Gasket	Stainless Steel	AISI316L	SUS316L
⑧ ^{MR}	Cover Gasket	Stainl. Steel/Graphite	AISI316L	SUS316L
⑨ ^R	Float Cover	Stainless Steel	AISI304	SUS304
⑩ ^R	Screen	Stainless Steel	AISI430	SUS430
⑪ ^R	Snap Ring	Stainless Steel	AISI304	SUS304
⑫ ^R	X-element Guide	Stainless Steel	AISI304	SUS304
⑬ ^R	Air Vent Valve Seat	Stainless Steel	AISI303	SUS303
⑭ ^R	X-element	Stainless Steel	—	—
⑮	Connector	Stainless Steel	AISI416	SUS416
⑯	Cover Bolt	Stainless Steel	AISI304	SUS304
⑰	Nameplate	Stainless Steel	AISI304	SUS304
⑱ ^R	Air Vent Screen	Stainless Steel	AISI304	SUS304
⑲ ^R	Snap Ring	Stainless Steel	AISI304	SUS304
⑳ ^R	Air Vent Valve Plug	Stainless Steel	AISI420F	SUS420F
㉑ ^R	Bimetal Plate	Bimetal	—	—
㉒ ^R	Air Vent Case	Cast Stainless Steel	A351 Gr.CF8	—
㉓	Socket**/Flange**	Cast Stainless Steel	A351 Gr.CF8	—
㉔	Drain Plug Gasket***	Stainless Steel	AISI316L	SUS316L
㉕	Drain Plug***	Stainless Steel	AISI303	SUS303

* Equivalent ** Shown on reverse, sockets 1" are welded on *** Option
Replacement kits available: (M) maintenance parts, (R) repair parts, (F) float

Connections and sizes in bold are standard

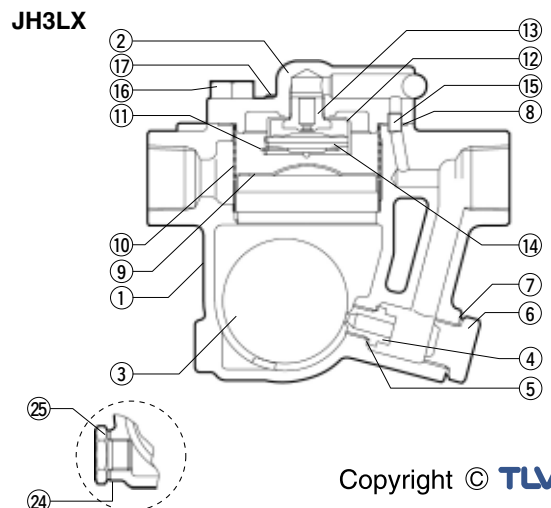
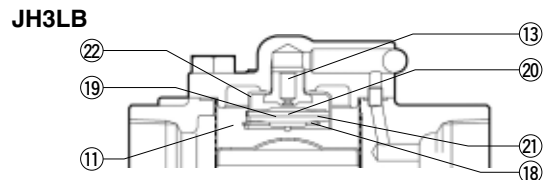

Dimensions

● **JH3LX/JH3LB** Screwed

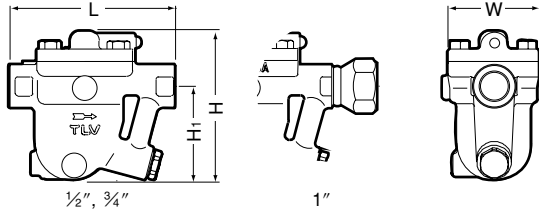

JH3LX/JH3LB Screwed* (in)

Size	L	H	H ₁	Weight (lb)
1/2	5 11/16	5 1/16	3 3/4	5.9
3/4				6.2
1	8			

* NPT, other standards available

● **JH3LX/JH3LB** Socket Weld

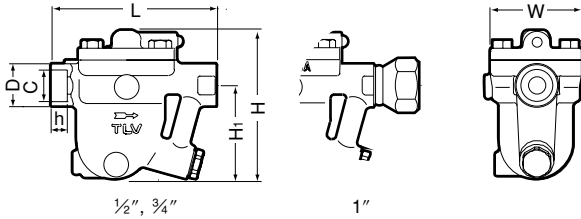

JH3LX/JH3LB Socket Weld (in)

Size	L	H	H ₁	φ D	φ C	h	Weight (lb)
1/2	5 11/16	5 1/16	3 3/4	1 7/16	7/8	1/2	5.9
3/4				1 1/16	9/16		
1	8			1 3/4	1 3/8		6.2

● **JH3LX/JH3LB** Flanged

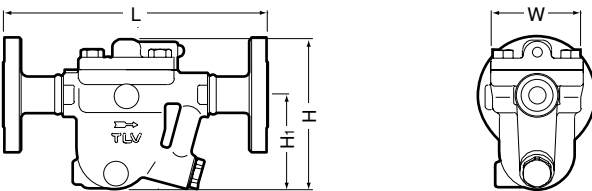

JH3LX/JH3LB Flanged (in)

Size	L			H	H ₁	Weight* (lb)
	ASME Class					
	150RF	300RF	600RF			
1/2	8 3/4	8 3/4	8 11/16	5 1/16	3 3/4	9.5
3/4	9 1/16	9 1/16	9 1/16			11
1	9 13/16	9 13/16	9 13/16			13

Other standards available, but length and weight may vary

* Weight is for Class 600 RF

Flange classes in bold are standard

Discharge Capacity

● **JH3LX**

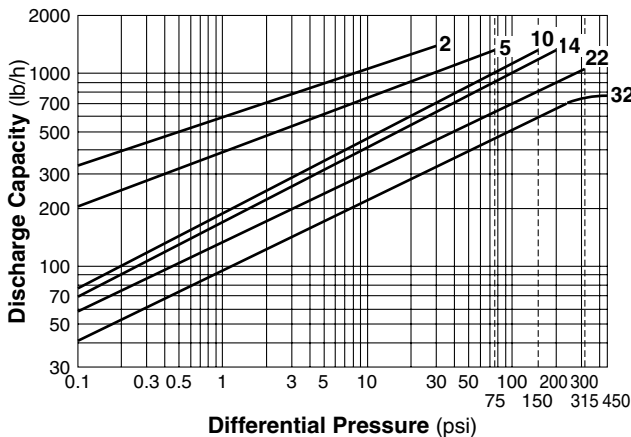

● **JH3LB**

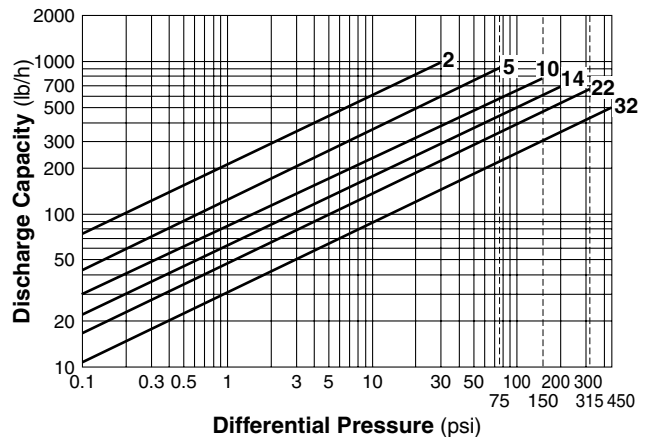

1. Line numbers within the graph refer to orifice numbers.
2. Differential pressure is the difference between the inlet and outlet pressure of the trap.
3. Capacities are based on continuous discharge of condensate 11°F below saturated steam temperature.
4. Recommended safety factor: at least 1.5.

CAUTION DO NOT use traps under conditions that exceed maximum differential pressure, as condensate backup will occur!

TLV CORPORATION

13901 South Lakes Drive, Charlotte, NC 28273-6790
 Phone: 704-597-9070 Fax: 704-583-1610
 E-mail: tl@tlvengineering.com
 For Technical Service 1-800 "TLV TRAP"



Manufacturer
TLV CO., LTD.
 Kakogawa, Japan
 is approved by LRQA Ltd. to ISO 9001/14001

ISO 9001/ISO 14001

