



SELF-ACTING UNBALANCED TEMPERATURE REGULATOR

MODEL TC1

TEMPERATURE REGULATING VALVE FOR NON-HAZARDOUS LIQUIDS AND GASES

Features

Unbalanced self-acting single seat globe valve type temperature regulator. Suitable for steam heating of liquids, air and non-hazardous gases.

1. Self-acting design simplifies installation by eliminating the need for power supply and instrument signal lines.
2. No external energy required, allowing for ease of installation in remote areas or potentially flammable atmospheres.
3. Robust design minimizes maintenance.
4. Reliable long-life spring mechanism protects the sensor from overheat damage.
5. Wide set point range and simple set point adjustment provide easy operation.



Specifications

VALVE

Model	TC1					
Size (DN)	15	20	25	32	40	50
Kvs Value (DIN)	4	6.3	8	16	20	32
Cv Value (UK)	3.9	6.1	7.8	15.6	19	31
Cv Value (US)	4.7	7.4	9.4	19	23	37
Maximum Allowable Differential Pressure* (bar) ΔPMX	25	16	14	6	6	4
Leakage Rate	< 0.05% of Cv (Kvs) value					
Body Material	Cast Iron GG-25		Ductile Cast Iron GGG40.3		Cast Steel GS-C 25	
DIN Material Number (WN)	0.6025		0.7043		1.0619	
ASTM/AISI Equivalent	A126 Cl.B		A395		A216 Gr. WCB	
Connection	Flanged DIN 2501 PN 16**		Flanged DIN 2501 PN 25		Flanged DIN 2501 PN 40**	
Maximum Operating Pressure (barg) PMO	13		16***			
Maximum Operating Temperature (°C) TMO	200		220			

* Subject to limitations of body pressure rating ** ASME standards also available *** Higher pressures possible with optional isolation piece 1 bar = 0.1 MPa

THERMOSTAT

Model	TC-A
Suitable for Immersion in***	Liquids compatible with sensor material
Set Point Range***	20 °C to 120 °C
Maximum Temperature at Sensor	Set Point Value + 100 °C
Ambient Temperature Limits at Adjustment Head	- 40 °C to 80 °C
Capillary Tube Length*** (m)	3

*** Other options available, see overleaf for details

PRESSURE SHELL DESIGN CONDITIONS (NOT OPERATING CONDITIONS):

Maximum Allowable Pressure (barg) PMA:
 13 (Cast Iron), 16 (Ductile Cast Iron & Cast Steel)
 Maximum Allowable Temperature (°C) TMA:
 200 (Cast Iron), 220 (Ductile Cast Iron & Cast Steel)

CAUTION To avoid abnormal operation, accidents or serious injury, DO NOT use this product outside of the specification range. Local regulations may restrict the use of this product to below the conditions quoted.

No.	Description	Material	DIN	ASTM/AISI*
①	Body	As specified above		
②	Seat	Stainless Steel	1.4006	AISI 410
③	Plug	Stainless Steel	1.4006	AISI 410
④	Bellows Housing	Carbon Steel	1.0305	A106 Gr. A
⑤	Plug Stem	Stainless Steel	1.4301	AISI304
⑥	Operating Element	Nicke-plated Brass	-	-
⑦	Body Gasket	Graphite on Metal Core	-	-
⑧	Capillary Tube	Nickel-plated Copper	-	-
⑨	Temperature Sensor	Nickel-plated Bronze	-	-

* Equivalent materials

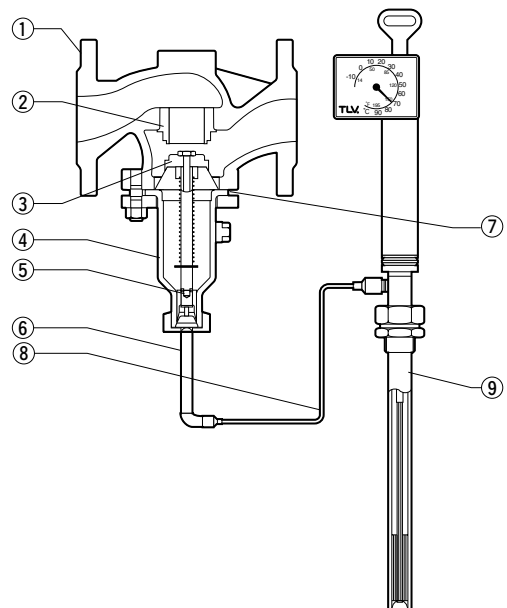

Dimensions

● **TC1**
Flanged

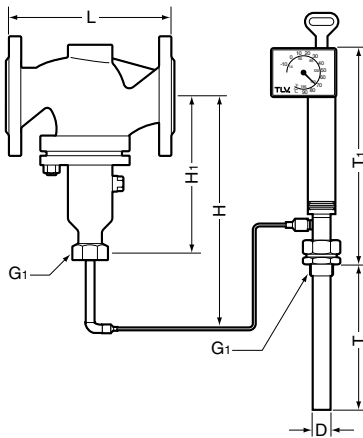

TC1 Flanged* (mm)

DN	L		H	H ₁	Weight** (kg)
	DIN 2501 PN16	PN25/40			
15	130		515	225	4.0
20	150				4.5
25	160				5.5
32	180				10
40	200				12
50	230				14

* ASME standards available for cast Iron and cast steel body
** Approximate weight for DIN 2501 PN 16, add 15% for PN 25/40

Thermostat*** (mm)

φD	T	T ₁	G ₁	Weight (kg)
25	290	310	1 inch	3.2

*** Standard model shown, other options available

Capacities (kg/h)

For a pressure drop of 10% P₁ across the valve:
(Coil and steam trap follow the regulator)

P ₁ (barg)	DN 15	DN 20	DN 25	DN 32	DN 40	DN 50
1	40	64	81	162	203	325
2	70	110	140	280	351	561
3	99	156	198	396	495	792
4	127	201	255	511	638	1022
5	156	246	312	625	781	-
6	184	291	369	739	924	-
7	213	336	426	-	-	-
8	241	380	483	-	-	-
9	270	425	540	-	-	-
10	298	470	597	-	-	-
11	327	515	654	-	-	-
12	355	560	711	-	-	-
13	384	605	768	-	-	-
14	412	649	825	-	-	-
15	441	694	-	-	-	-
16	469	739	-	-	-	-

For a pressure drop of 50% P₁ across the valve:
(Direct steam injection system follows the regulator)

P ₁ (barg)	DN 15	DN 20	DN 25	DN 32	DN 40	DN 50
1	113	178	227	454	568	908
2	170	268	340	681	852	1363
3	227	357	454	908	1136	1817
4	284	447	568	1136	1420	2272
5	340	536	681	1363	1704	-
6	397	626	795	1590	1988	-
7	454	715	908	-	-	-
8	511	805	1022	-	-	-
9	568	894	1136	-	-	-
10	624	984	1249	-	-	-
11	681	1073	1363	-	-	-
12	738	1162	1476	-	-	-
13	795	1252	1590	-	-	-
14	852	1341	1704	-	-	-
15	908	1431	-	-	-	-
16	965	1520	-	-	-	-

1 bar = 0.1 MPa

Options

Item	Options
Isolation Piece	Allows ductile cast iron valve for use up to 19 barg and cast steel valve up to 25 barg
Thermostat (Model)	Suitable for immersion in liquid with separate set point adjustment (TC-B) Suitable for immersion in air or gas with set point adjustment at sensor (TC-C) Suitable for immersion in air or gas with separate set point adjustment (TC-D) All models available in stainless steel construction
Set Point Range	50 °C to 150 °C 150 °C to 250 °C (separate set point adjustment only)
Capillary Tube Length	5 m 10 m
Capillary Tube Material	Stainless steel construction

Manufacturer

ISO 9001/ISO 14001

TLV CO., LTD.
Kakogawa, Japan

is approved by LRQA Ltd. to ISO 9001/14001

