



# PowerTrap®

## MODEL GP5C

### COMPACT MECHANICAL PUMP FOR CONDENSATE REMOVAL AND RECOVERY

#### Features

**Pump with a linear inlet/outlet and low filling head. Ideal for low flow condensate removal from vented receivers situated at a low level in open systems.**

1. Handles high-temperature condensate without cavitation.
2. No electric power or additional level controls required, hence **INTRINSICALLY SAFE**.
3. Pump will operate with an extremely low filling head (min. 155 mm).
4. Linear inlet/outlet greatly reduces installation time.
5. Easy, inline access to internal parts simplifies cleaning and reduces maintenance costs.
6. High-quality stainless steel internals and hardened working surfaces ensure reliability.
7. Compact design permits installation in a limited space.



#### Specifications

Model		GP5C			
Body Material		Cast Iron		Cast Stainless Steel	
Connection	Pumped Medium Inlet & Outlet	Screwed	Flanged*	Screwed	Flanged*
	Motive Medium & Pump Exhaust	Screwed			
Pumped Medium: Inlet x Outlet		25 x 25			
Size (mm)	Motive Medium Inlet	15			
	Pump Exhaust Outlet	8			
Maximum Operating Pressure (MPaG)	PMO	0.5			
Maximum Operating Temperature (°C)	TMO	185			
Motive Medium Pressure Range (MPaG)		0.03 - 0.5			
Maximum Allowable Back Pressure		0.05 MPa less than motive medium pressure used			
Volume of Each Discharge Cycle (ℓ)		Approximately 1.5			
Motive Medium**		Saturated Steam, Compressed Air, Nitrogen			
Pumped Medium***		Steam Condensate, Water			

\* Screwed-in flange \*\* Do not use with toxic, flammable or otherwise hazardous fluids. 1 MPa = 10.197 kg/cm<sup>2</sup>  
 \*\*\* Do not use for fluids with specific gravities under 0.85 or over 1, or for toxic, flammable or otherwise hazardous fluids.

**PRESSURE SHELL DESIGN CONDITIONS (NOT OPERATING CONDITIONS):**

Maximum Allowable Pressure (MPaG) PMA: 1.0  
 Maximum Allowable Temperature (°C) TMA: 220



To avoid abnormal operation, accidents or serious injury, DO NOT use this product outside of the specification range. Local regulations may restrict the use of this product to below the conditions quoted.

No.	Description	Material	JIS	ASTM/AISI*
①	Body	Cast Iron	FC250	A126 Cl.B
		Cast Stainless Steel	—	A351 Gr.CF8M
②	Cover	Cast Iron	FC250	A126 Cl.B
		Cast Stainless Steel	—	A351 Gr.CF8M
③ <sup>M</sup>	Cover Gasket	Fluorine Resin	PTFE	PTFE
④ <sup>F</sup>	Float	Stainless Steel	SUS316L	AISI316L
⑤ <sup>R3</sup>	Snap-action Unit	Stainless Steel	—	—
⑥ <sup>R6</sup>	Snap-action Spring**	Stainless Steel	—	—
⑦ <sup>R1</sup>	Intake-Exhaust Valve Unit	Valve	SUS440C	AISI440C
		Valve Seat	Stainless Steel	SUS440C
⑧ <sup>R4</sup>	Outlet Check Valve Unit	Stainless Steel	SUS304	AISI304
⑨ <sup>R2</sup>	Exhaust Plug	Stainless Steel	—	—
⑩ <sup>R5</sup>	Inlet Check Valve Unit	Stainless Steel	SUS304	AISI304
⑪ <sup>M</sup>	Seal Set	—	—	—

\* Equivalent \*\* Also included in R3 (Snap-action Unit repair kit)  
 Replacement kits available: (M) maintenance parts, (R1-R6) repair kits, (F) Float  
 When ordering a repair kit or other parts, it is recommended to order additional maintenance parts (M) as replacement gaskets may be required

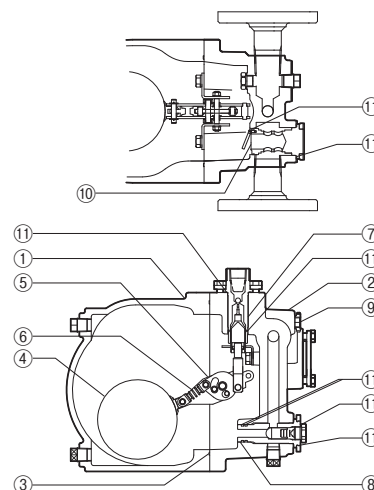

**Dimensions**

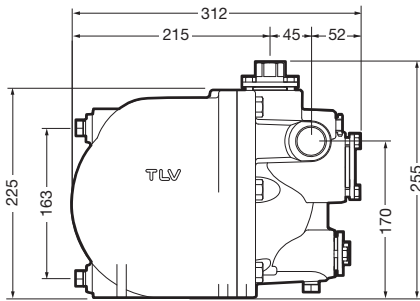

• **Screwed\***

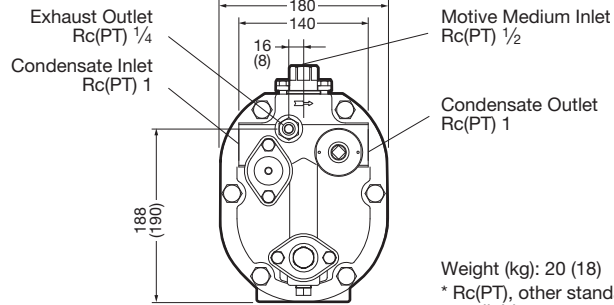

Units: mm

Weight (kg): 20 (18)  
\* Rc(PT), other standards available

• **Flanged\*\*** (Screwed-in flange)

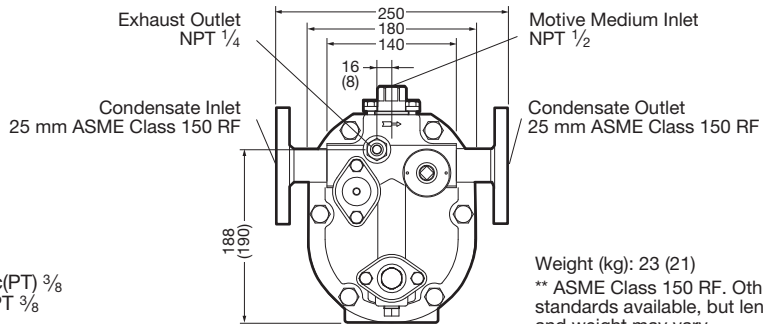

Weight (kg): 23 (21)  
\*\* ASME Class 150 RF. Other standards available, but length and weight may vary.

Note: All Plug Holes are:  
For Rc(PT) screw connection model: Rc(PT) 3/8  
For ASME screw connection model: NPT 3/8  
( ) is for Stainless Steel

**Discharge Capacity**

Connection:	Screwed/Flanged
Inlet size:	25 mm
Outlet size:	25 mm
Check Valve:	Inlet (built-in) Outlet (built-in)
Filling Head:	300 mm

System Back Pressure (kg/cm<sup>2</sup>G)

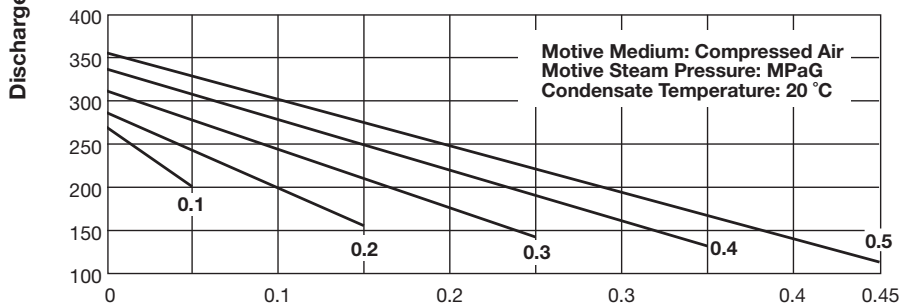
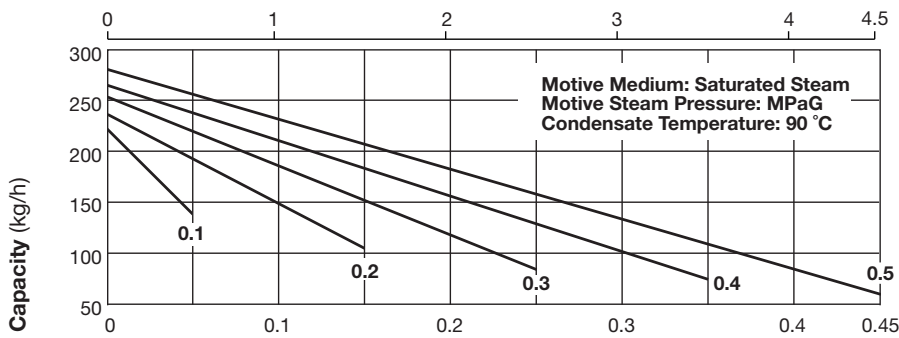

• **Correction Factor**

For GP5C installed with filling head other than 300 mm (minimum filling head: 155 mm)

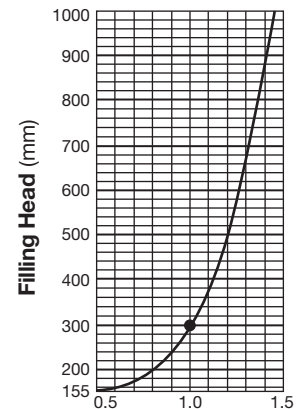

### Illustration of Filling Head and Pressures

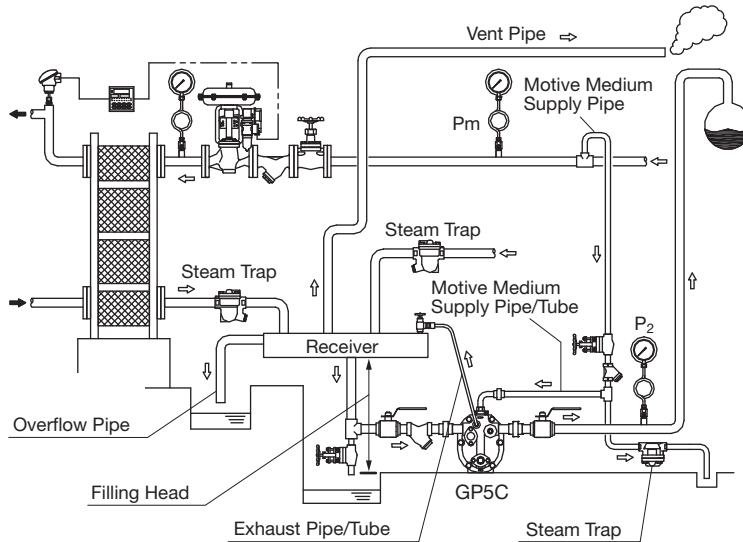

The discharge capacity is determined by the motive medium, motive medium pressure (Pm) and back pressure (P2).

Make sure that:  
 Discharge Capacity × Correction Factor > Required Flow Rate

For explanation purposes only, not intended as an installation design.

**NOTE:**

- GP5C should be used in an open system in which the receiver is open to the atmosphere.
- Motive medium pressure minus back pressure must be greater than 0.05 MPa.
- The motive medium supply pipe diameter should be at least 15 mm, and the motive medium supply pipe/tube and its fittings/valves should have an inner diameter of at least 8 mm.
- A 40 mesh or finer strainer must be installed at the motive medium and pumped medium inlets.

### Receiver Sizing Table

The receiver must have a capacity sufficient to store the condensate produced during the PowerTrap operation and discharge. A receiver that must handle the condensate both as a liquid and as flash steam will generally be larger than a receiver that handles condensate only as a liquid, and should separate one from the other so that only condensate is sent to the PowerTrap. When supercooled condensate is pumped, there may be cases in which hardly any flash steam is produced.

**1. Size of Receiver; flash steam is involved**  
 (Length: 1 m)

Flash steam up to (kg/h)	Receiver diameter (mm)	Vent pipe diameter (mm)	Overflow pipe diameter
25	80	25	Overflow pipe diameter should be equal to or greater than the condensate inlet pipe diameter.  Diameter for receiver must be equal to or more than 3× the overflow pipe diameter.
50	100	50	
75	125	50	
100	150	80	

**2. Size of Receiver; flash steam is not involved**  
 (Length: 1 m)

Amount of condensate (kg/h)	Receiver diameter (mm)
50 or less	25
100	40
200	40
300	50
400	65
500	80

- Receiver length can be reduced by 50% when the motive medium pressure (Pm) divided by back pressure (P2) equals 2 or greater (when  $P_m \div P_2 \geq 2$ ).

**Memo:**

---

**Manufacturer**  
**TLV**® **CO., LTD.**  
Kakogawa, Japan  
is approved by LRQA Ltd. to ISO 9001/14001

